

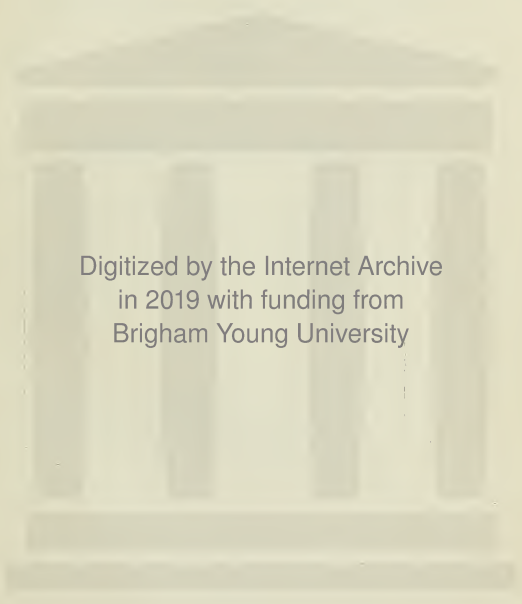

362

12 250
37
66 -
54
80
114



Digitized by the Internet Archive
in 2019 with funding from
Brigham Young University

WORKS OF
ALVAH H. SABIN
PUBLISHED BY
JOHN WILEY & SONS

The Industrial and Artistic Technology of Paint and Varnish.

8vo, vi+372 pages, illustrated. Cloth, \$3.00.

House Painting

Glazing, Paper Hanging, and Whitewashing.
A Book for the Householder. 12mo. ix+121
pages. Cloth, \$1.00

TRANSLATION

German Varnish-Making.

By PROFESSOR MAX BOTTLER, of Würzburg.
Authorized Translation with Notes on Amer-
ican Varnish and Paint Manufacture. By
ALVAH HORTON SABIN. Large 12mo, vii+363
pages, 55 figures. Cloth, \$3.50 net.

6877
B659g

German Varnish-Making

by

PROFESSOR MAX BOTTLER

of Würzburg

Authorized Translation with
Notes on American Varnish and Paint Manufacture

by

ALVAH HORTON SABIN, M.S.

Member Am. Chem. Soc ; A. S. Testing Materials, A.S.M.E., etc. ; Lecturer, New York
University ; Consulting Chemist, National Lead Company

First Edition
First Thousand

NEW YORK
JOHN WILEY & SONS
LONDON: CHAPMAN & HALL, LIMITED

1912

Copyright 1912 by
ALVAH HORTON SABIN

Composition, Printing and Electrotyping by
PUBLISHERS PRINTING COMPANY, New York, U.S.A

THE LIBRARY
BRIGHAM YOUNG UNIVERSITY

TRANSLATOR'S PREFACE.

FOR several years information as to progress in varnish manufacture in Germany has been obtained only through the German journals, which are not generally accessible in America; so the publication of a new book on the subject by Professor Bottler, who has made a scientific and practical study of the same, calls for an English translation. It is perhaps too concise and brief, being written for those who are somewhat familiar with German methods, but it is at any rate authoritative and full of interest. The translator thought best to add to it various notes, which in the end amounted to additions so considerable that it seemed well to call attention to the fact in the title of the book. The translation is printed in such a manner as to be distinct from these additions and easily recognized; in these additions it has been the aim to avoid repeating anything to be found in the translator's former book (*Technology of Paint and Varnish*), but to make this supplementary to that earlier treatise, acquaintance with which is presumed on the part of the reader of the present work. This necessarily gives the matter thus added a fragmentary character which it is hoped may be excused on the ground that the collection and publication of facts is the aim, rather than literary effect.

Much of this added matter has to do with paints, and it may be questioned whether it is in place in a book on varnish. But in reality the two are inseparably connected;

and paint is practically a modified liquid, in a sense not generally appreciated. To make this more evident, let the reader look at the description of Thompson's classifier on pages 200-213 and the accompanying photographs. The average diameter of the particles of white lead in cone 1 is about one one-thousandth of an inch. By spreading these particles on the stage micrometer of a microscope, which is a small glass plate ruled by a diamond with lines one one-thousandth of an inch apart, these particles may be measured with the microscope as easily as if they were potatoes laid on a foot-rule on the floor. Like potatoes they are not all the same size, but they average about a thousandth of an inch. The laws of floating heavy particles by flowing liquids have been sufficiently investigated in times past by physicists and others, and from them we know that in cone 2 the particles average one four-thousandth of an inch, in cone 3 one sixteen-thousandth, and in cone 4 one sixty-four thousandth of an inch. If the particles in the fifth portion had been separated, the fifth portion would average one two-hundred-and-fifty-six-thousandth; but in fact must be finer than that, for all the finer particles are there collected, and when seen with a microscope provided with a one-eighth or one-twelfth objective the limits of fineness are difficult to tell, so small are they. But assuming, for the sake of getting a definite notion, that they are one two-hundred-and-fifty-six-thousandth of an inch in diameter, it is obvious that of these, which in the best white lead amount to 92 or 93 per cent, that great number (256,000) could be placed, touching one another, along a line one inch long. To make a single layer over a square inch, two hundred and fifty-six thousand such rows are required; that is, they would make a single row

256,000 inches long, or over 20,000 feet, or about four miles. And in a cubic inch there would be 256,000 such layers, or enough particles to reach $256,000 \times 4$ miles, or a million miles. It takes 4.2 cubic inches of white lead to weigh a pound; so that in a twenty-five-pound pail of white lead there are enough particles to make a continuous line reaching from here to the sun.

People generally do not realize how small these pigment particles are. Some one has asked whether in assuming these figures we are not approaching the size of a molecule. Sir William Thompson (Lord Kelvin) concluded from a study of several methods of measurement that the distance between centres of contiguous molecules in a solid may be not more than one hundred-millionth and not less than one two-thousand-millionth of a centimetre. If we assume that $2\frac{1}{2}$ cm. equal one inch, we have as the coarsest estimate 250,000,000 to the linear inch, or 1,000 to the diameter, equal to 1,000,000,000 to the volume of one white-lead particle; or by the finest estimate there would be 5,000,000,000 to the inch, or 20,000 to the diameter and 8,000,000,000,000 molecules to the volume of the white-lead particle; so it seems there are enough molecules to go around. Molecules are really very small.

When we consider the small size and vast number of these particles and think how easily they must move among themselves, especially when floating in oil, it seems reasonable to class paint among the liquids, as has been said, and that facts about it may properly be put down in connection with those about varnish. At all events, that is what has been done.

Some of the analytical matter is old, but much is new and some is now published for the first time. If the book

proves to be useful it will need no apology; such diverse material could not be very well classified.

The old Crockett formula-book, now first printed, is unique; Crockett was the inventor of the American varnish-kettle, and of most of the methods used to this day in America; the formulas are, of course, out of date, but as historical matter the whole is of great interest; and while the translator is under obligation to so many of his friends that he cannot here enumerate them, all will feel a special appreciation of the liberality which allowed the publication of these formulas and directions.

It is with great pleasure that the writer introduces Professor Bottler's book to the American and English varnish-makers.

A. H. SABIN.

FLUSHING, NEW YORK, 1912.

CONTENTS.

CHAPTER	PAGE
I. INTRODUCTORY AND HISTORICAL	1
II. CLASSIFICATION OF LACQUER AND VARNISH	4
III. RAW MATERIAL FOR MAKING LACQUER AND VARNISH	6
IV. MAKING LACQUER AND VARNISH	69
V. OIL-VARNISH AND OLEORESINOUS VARNISH	78
VI. TURPENTINE AND BENZINE VARNISHES	118
VII. ALCOHOLIC AND OTHER VOLATILE AND NON-VOLATILE VARNISHES	123
VIII. THE COLORING, BLEACHING, AND FILTERING OF LACQUERS AND VARNISHES	137
IX. MANUFACTURE OF PRINTERS'-INK, LITHOGRAPHIC-VARNISH, SOAP, RESIN AND CASEIN LACQUERS	144
X. NOTES ON VARNISH-MAKING	151
XI. PAINT: ITS CONSTITUTION AND NATURE	179
APPENDIX	
I. NOTES ON ANALYTICAL METHODS	233
II. CROCKETT'S VARNISH FORMULAS	333

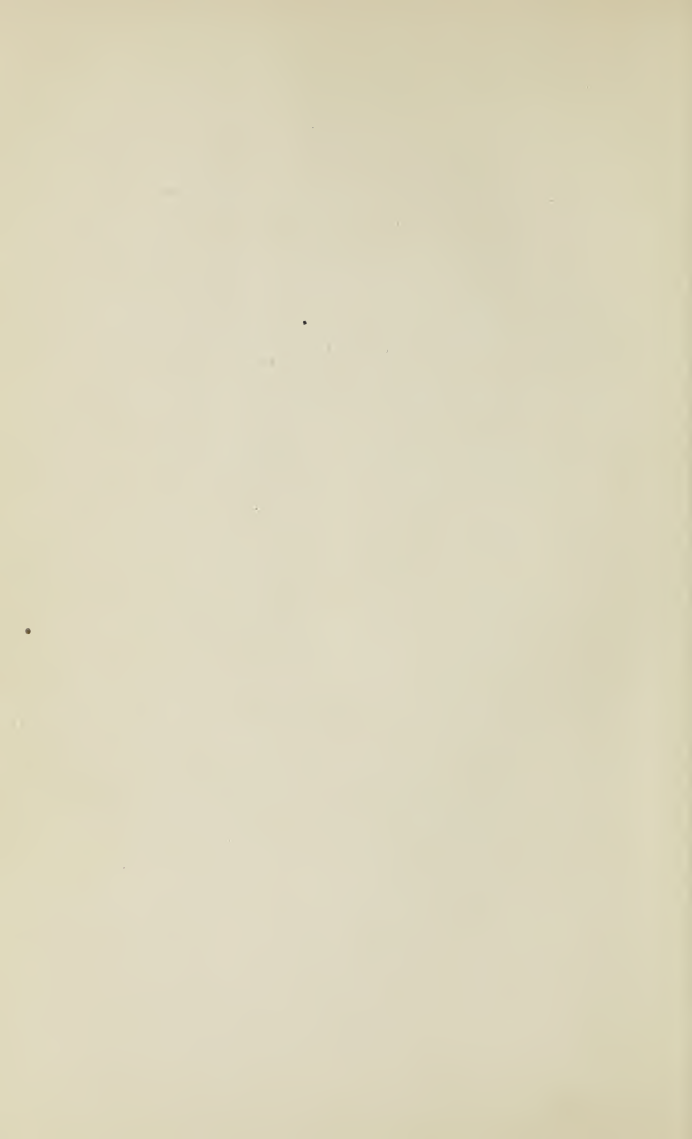

VARNISH-MAKING

CHAPTER I

INTRODUCTORY AND HISTORICAL

LACQUER and varnish are liquids which when spread out in a thin film on a surface become quickly changed so that they form a solid coating, colorless or nearly so; but having color in special cases. The face of the dry film as a rule is smooth and shining, but is sometimes purposely made dull, or what is called a mat surface. If the film is decidedly colored, it is purposely so made. We therefore cover various objects with lacquer or varnish to give them a pleasing appearance; but at the same time they are protected against external injury.

A good lacquer or varnish has these qualities:

1. It must dry within a short time after its application.
2. The dry film is uniform, hard, and lustrous, except that certain varnishes have a mat surface.
3. The finished coating is without cracks or flaws, and sufficiently elastic to permit of a limited bending of the foundation.
4. It must be unaffected by atmospheric influences.

In general we understand that lacquers consist of hard resins dissolved in suitable solvents.

If the solvent is volatile, as, *e.g.*, ethyl or methyl alcohol,

ether, spirit of turpentine, etc., the dissolved substance is left as a continuous film.

Sometimes the solvent is of such nature that it hardens on exposure to the air, as linseed and other drying-oils, whereby the dissolved resin is enclosed and protected.

Details of the differences between lacquer and varnish, and their classification, will be found in the next chapter.

As to the time during which we have used these materials on articles of art or use, we can fix no definite estimate. Although the origin of lacquers and varnishes must have been at an early period, it is probable that they began to be used in Germany in the Middle Ages.

In Japan, according to Quinn, lacquer was used 500 or 600 years B.C. On the contrary, Tschirch and A. B. Stevens argue that the Japanese did not have this art, nor indeed the lacquer-producing tree, until the third century, having learned it from their western neighbors after their first war with Corea; and that the Asiatic peoples of an older civilization, as those of China and India, knew the art at a much earlier period. The art of lacquering was especially developed in Japan during the Middle Ages, reaching its highest point in the seventeenth century.

For a long time the finest lacquer-work has been brought to Europe from Japan. The Japanese and Chinese have at their command for carrying on their work, oils and resins, which are in the highest degree suitable for the production of lacquer. By inspecting Japanese and Chinese lacquered wares it is obvious that the greatest care and conscientiousness were employed in their fabrication. While the Grecian painter Apelles, as early as the fourth century B.C., used varnish for his paintings, nevertheless, as has been said, it did not come into common use with us until the Middle Ages.

Early History of Varnish; Eastlake, Materials, etc.; Merrifield, Treatises, and Cennini, Sabin, Technology of Paint and Varnish.

In the twelfth century a monk named Theophilus published the first directions for making linseed-oil varnish; from this date various formulæ for making lacquers and varnishes are known. In the sixteenth and seventeenth centuries the making of lacquer took an extraordinary advance. By the establishment of traffic with the Orient at that time our attention was persistently drawn to the use of lacquer. Knowledge of lacquer led to its use, and in the sixteenth century shellac became known, and later turpentine, sandarac, amber, and mastic were used as ingredients.

CHAPTER II

CLASSIFICATION OF LACQUER AND VARNISH

LACQUERS and varnishes may be classed under the following three groups:

1. Oil-varnish and oleoresinous varnish.
2. Spirit varnishes made with spirit of turpentine, benzine, etc.
3. Alcoholic varnishes made with alcoholic and similar volatile solvents.

a. By oil-varnish we mean a liquid which hardens by the chemical change of a vegetable drying-oil. By this change a thin layer of the liquid oxidizes in the air and hardens into a transparent, elastic coating.

b. Lacquers are liquids whereof the fluidity is lost by the evaporation of the whole or a part of the solvent. Oleoresinous varnishes contain melted copal and other hard resins dissolved in drying-oil and spirit of turpentine, and in changing to a solid the latter evaporates, while the resin remains in union with the drying-oil (linseed). The drying-oil has the property of taking oxygen from the air, which causes the film to harden gradually. In the use of spirit varnishes made with resins and spirit of turpentine, benzine, etc., as solvents, these latter evaporate and leave a solid residue. Turpentine itself absorbs oxygen and has some effect on the hardening of the varnish, while benzine and turpentine substitutes only act by being volatile. Varnishes made by dissolving resins in alcohol, ether, and

similar fluids dry on account of these liquids being extremely volatile; when they evaporate they leave the resin in a thin glossy layer (but sometimes with a mat surface). In this last class are the celluloid lacquers and others using some of the solvents recently come into use.

CHAPTER III

RAW MATERIAL FOR MAKING LACQUER AND VARNISH

1. Balsams, resins, and various natural and artificial products.

a. Balsams.—These include copaiba balsam and the natural turpentine.

b. Resins.—Here we class the copals, dammar, lac (shellac), mastic, sandarac, elemi, rosin, hardened rosin, benzoin, and amber. With the exception of hardened rosin these are all natural products. Benzoin serves only as a perfume and to give lustre; all the rest are recognized as varnish resins. Chinese and Japanese lacquer may be included under this classification.

c. Color Resins.—Among these are button-lac, acaroid resins (yellow and red), dragon's blood, and gamboge. Button and stick lac are varieties of lac (shellac).

d. Various Natural and Artificial Products.—Here we place natural asphalt, coal-tar pitch, gutta-percha, caoutchouc, vulcanized rubber, ceresin, wax, paraffin, spermaceti, camphor, rosin ester, pyroxylin or nitrocellulose, and celluloid.

2. Drying Oils.—These are linseed, poppy, castor, Chinese and Japanese wood-oil. Linseed is by far the most important. Hemp-seed-oil, sunflower-oil, walnut-oil, and cotton-oil are but seldom used.

3. Spirit of Turpentine, Rosin-oil, and Volatile Liquids.—

These are turpentine, rosin-spirit, petroleum, benzine (petroleum-ether), benzole (coal-tar benzine), chlorbenzol, ethyl and methyl alcohol, ether, acetone (dimethyl ketone), methyl-ethyl-ketone, acetylene tetrachloride, carbon tetrachloride, carbon bisulphide, chlorhydrin.

4. Coloring Matters.—Besides those already mentioned are the coal-tar colors, annatto, turmeric, aloes, dyewoods, lampblack, various chemical colors, and mineral colors.

5. Chemical Products.—Here we include litharge, red lead, orange lead, sugar of lead, lead resinate, lead linoleate; manganese suboxide, hydroxide, and dioxide, permanganate of potash, borate of manganese, resinate of manganese, linoleate of manganese, resinate of lead and manganese, resinate of zinc.

I. BALSAMS, RESINS, AND VARIOUS NATURAL AND ARTIFICIAL PRODUCTS

a. **Balsams.**—*Copaiba balsam* is obtained from various species of *Copaifera*, of the Leguminosæ, which grow in South America, especially in Venezuela and Brazil.

The Brazilian balsam is clear and thick (viscous); it has a characteristic aromatic odor, and a pale yellow color. Its specific gravity is from 0.92 to 0.99, while the less viscous and somewhat more deeply yellow balsam from Para has a specific gravity of 0.92 to 0.95. The Brazilian is a solution of two resins in a volatile oil (oil of *copaiba*), and is easily soluble in absolute alcohol, in ether, and in fixed oils; Para *copaiba* is not entirely soluble in alcohol. *Copaiba*, especially the more thinly-fluid sorts (as Para), is used in various lacquers, especially in combination with shellac and castor oil; the mixture is melted, cooled, pulverized, and dissolved in 95-per-cent alcohol.

Turpentine.—Turpentine is obtained from various coniferous trees, especially in Europe and North America. Pines and firs yield the ordinary turpentine; a better grade is obtained from the silver fir. Among the finer turpentines are the true larch-turpentine and Canada balsam.

The ordinary varieties of turpentine vary in viscosity; the inferior sorts contain much rosin acids and the better are less acid. The yield of spirit of turpentine, which is the most valuable ingredient, varies with the method of extraction. Crude turpentine is a substance intermediate between spirit of turpentine and rosin. In high-class work the so-called Venetian (larch) turpentine is used. Fine turpentine is clear or only slightly turbid; common turpentine is persistently turbid, even when warmed. The average boiling-point is 130° C.; specific gravity about 0.856; Canada balsam and some others have a higher density. All turpentines are soluble in alcohol, ether, spirit of turpentine, benzine, etc., making more or less clear solutions; they mix, when melted, with the fixed oils, but often on cooling a partial separation takes place. Also the thick turpentine and larch-turpentine are soluble in mono- and dichlorobenzoles.

Turpentine is used because of its viscosity to lessen the brittleness of various varnishes and lacquers; for example, it is added to a resin-lacquer of pale or dark rosin in alcohol; for pale lacquer Venetian and for the dark lacquer ordinary thick turpentine is used. Similarly the pale or dark turpentines are used with spirit-lacquers made from Manila or Borneo resins; even galipot is used in this way.

b. Resins.—*Copals.* Under the name of copal we include a group of resins, distinguished from others by their greater

hardness, higher melting-point, and less solubility in the ordinary solvents for resins.

Copals come from East and West Africa, from the Sunda Islands, the Philippines, Molucca, New Zealand, New Caledonia, and South America. From East Africa come Zanzibar, Madagascar, and Lindy resins; from West Africa, Angola, Benguela, Congo, Sierra Leone, Pebble, and Cameroon resins. From the Sunda Islands, the Philippines, and Molucca we obtain Manila resin, and from the same regions Java and Borneo resins. New Zealand and New Caledonia yield Kauri.

From South America we get Brazilian resin and Angostura resin from Venezuela. African resins are mostly dug from the earth; Zanzibar is a semi-fossil resin. When the copals are dug from the earth they are covered with an incrustation of decomposed resin more or less thickly, which is then cleaned off either with chisels or with dilute caustic alkali; it is then sorted according to its clearness and hardness. There is no recognized scale of hardness; but Zanzibar is reckoned the hardest, next Lindy resin; Madagascar, Sierra Leone, Angola, and Angostura are very hard; Benguela, Congo, Cameroon, and Accra resins are hard; Manila, Kauri, and Borneo moderately hard; South American *Hymenæa* copal and recent Sierra Leone are soft resins.

The harder the copal the more difficult it is to melt, as a general thing, requiring a higher heat. The best Zanzibar and Lindy copal melt at about 340° to 360° C. If, however, we take as a melting-point the temperature at which the resin becomes fluid without decomposition, such a point for Zanzibar and Lindy is from 250° to 270° C., for Sierra Leone 185° C., Benguela 170° to 175° C., Manila 112° to 135° C., and for South American (*Hymenæa*) copal 95° C.

In the ordinary solvents, such as alcohol, ether, spirit of turpentine, etc., it is very difficult to entirely dissolve copals. Some of the moderately hard, such as Manila, Borneo, and Kauri, are mostly soluble in 96 per cent alcohol, some of the harder sorts, as Cameroon and Pebble copals, dissolve in amyl alcohol, soft *Hymenæa* resin in a mixture of amyl and absolute alcohol—all these leave some insoluble residue—but in general if we wish to make perfect solutions of the copals we must first subject them to a process of roasting or melting. All the East African and most of the West African resins must be melted before any of the ordinary solvents will dissolve them, and even after melting some of them require prolonged digestion in the solvent. If the roasting or melting process has been properly conducted, the resins so treated dissolve easily in warm linseed-oil, spirit of turpentine, etc. It will be assumed in the following pages that by melting resin we mean such a complete and perfect operation, which is one of the critical operations of varnish-making.

Recently, solvents have been discovered which dissolve copals without preliminary treatment. As early as 1895, H. Flemming announced that he had been able to make permanent solutions of all copals in α -dichlorhydrin and epichlorhydrin. As regards copals from Brazil and Manila, also Kauri, my own investigations have shown them perfectly soluble in α -dichlorhydrin. Also methyl acetone dissolves Kauri and Brazilian resins completely, and the greater part of Manila. Terpeneol dissolves medium hard and soft copals (Manila, Kauri, and Brazilian) completely, and the greater part of many of the West African resins, as Angola and Sierra Leone. Carbon tetrachloride by itself dissolves permanently only the soft Brazilian resin, while

other copals are for the most part quite or nearly insoluble. The addition of 25 to 50 per cent of absolute alcohol to this solvent enables it to dissolve many copals, as Angola, white Benguela, Sierra Leone, and Cameroon, to solutions which are mostly clear, but colloidal or gelatinous.

Sometimes two solvents are used to dissolve a resin; so that one dissolves out a part, and the residue is dissolved in the other, as may sometimes be done with methyl alcohol and acetone.

It has long been known that the vapor of an alcoholic solution of camphor is a powerful solvent for resins. A solution of one part of camphor in twelve of ether is a good solvent for roasted copal. As a practical matter, it is worthy of note that copals which have become a swollen, syrupy mass by treatment with ether may be completely or in great part dissolved by adding this mass in small portions to warm alcohol; Manila, Kauri, and white and red Angola may be thus treated. These solutions may be diluted with hot alcohol; but if cold alcohol is added a partial separation will take place. Solution of finely powdered copal is helped by mechanically mixing with it dry sand or powdered glass or quartz; but this has little effect on the solubility, as a rule. However, the process of dissolving copal seems to be appreciably accelerated by pulverizing and triturating with the powdered copal about one-seventh of fluor-spar or antimony sulphide. According to recent investigations the addition of one-half of 1 per cent of sulphuric acid to alcohol greatly increases its solvent action on copal. Quite recently the so-called benzole mixture, which consists of equal parts of spirit of turpentine, bisulphide of carbon, and benzole, has been used to dissolve copal; white Angola, Congo, and Manila are mostly soluble in this mix-

ture, but the solution appears turbid. In the presence of chloral hydrate the solubility of copal is considerably increased; but this subject has not yet been fully investigated. In 80-per-cent chloral-hydrate solution Manila is largely and Kauri partly soluble.

Because in melting copal, and thereby driving off volatile oils, there is a considerable loss of weight, attempts are made to make copal varnish by cold processes. As the foregoing account shows, these attempts have not as yet been fully successful. Still, it is possible, using soft copals and suitably chosen solvents or mixtures of solvents, to make copal solutions which, by the addition of spirit of turpentine, alcohol, or other similar ingredients, may be used as lacquers. According to Smith, the soft and more easily soluble and fusible gum resins and resins are dissolved in linseed-oil or other oil, and this solution acts as a solvent for the more difficultly fusible and soluble resins, as copals and the like. Smith makes use of these methods to bring copals into solution without melting, to use as varnishes, by dissolving soft resins like damar and with this solution make a varnish of a hard resin at a relatively low temperature, at which the weight of the resin is not diminished and the natural properties of it are preserved.

Resenes, Tschirch, *Harze u. Harzbehälter*, p. 1090 *et seq.* Resenes are in general resin constituents containing oxygen, but not having the characters of acids, alcohols, aldehydes, ketones, lactones, or esters; they are not soluble in alkalies and are considered by Tschirch to be valuable resin constituents on account of their resistance to chemical action. Some are soluble, others not, in such solvents as alcohol, ether, petroleum ether, etc.

But the fact that resenes are present in considerable amount in Manila and other relatively soft and perishable resins, and are in much less proportion in the harder

and more valuable ones, does not appear to indicate that they are of special value.

Copals belong to that class of resins which are nearly free from resin acids or resin-oil acids, and also contain those very permanent substances, the resenes; they contain, moreover, ethereal oils, which are driven off by melting or distillation, a bitter principle, and coloring-matter. Zanzibar and Cameroon copals consist mainly of resin acids and resenes; in yellow Benguela and white Angola the principal ingredient is resin acid with a small admixture of resenes. Red Angola is similar but has more resenes. Sierra Leone, white Benguela, and Congo contain resistant substances in large proportions. Manila is composed mostly of resin acids; but it contains more resene (12 per cent) than does Zanzibar (6 per cent). Kauri is made up of free resin acid and some resene; Borneo (which resembles dammar) has resin acid and resene in equal proportions. The indifferent bodies, such as the resenes, outweigh the acids in varying proportions in the remaining resins; but Hymenæa copal from South America is chiefly composed of resin acids or resin-oil acids.

Concerning the technical use of copal, considering its composition, the conclusion is reached that the best to use in practice is that which is most permanent when subjected to decomposing influences of all sorts. The most valuable constituent of resins, especially copals, from this standpoint is resene. But as dammar shows a resene content of $62\frac{1}{2}$ per cent, while Zanzibar has only 6 per cent, and Manila 12 per cent, and the West African copals less than dammar, so according to the above method of estimating value dammar is the best resin. It appears reasonable to value more highly those resins which contain but little air enclosed in their

mass, which is determined by taking the specific gravity of the resin in its usual condition, and find the difference between this and the specific gravity of the same resin freed from contained air; resins showing small differences should be more valuable than their opposites. Thus treated, at 15° C., Zanzibar gives 1.0621 and 1.0636, the difference being 0.0015. Lindy copal shows a difference of 0.0010; red Angola, 0.014; Cameroon, 0.015; Manila, 0.059; Hymenæa copal (South American), 0.0615; and Kauri 0.064. The last three are according to this the least valuable, and so on; in general this agrees with the facts.

As a rule the harder resins are the more valuable. As has been already said, the class of the hardest includes Zanzibar, Lindy and red Angola, next comes Cameroon copal, then Kauri and Manila, and at the end Hymenæa copal. The conclusion that copals which show least difference of weights, as described, are most valuable, appears to be well supported by the foregoing data. Although copals show resistance to reagents in proportion as they contain resenes, yet they do not resist the action of solvents in like proportion, but rather the opposite; copals containing little resene are more difficultly soluble than those which contain more. Thus, Manila contains 12 per cent mancopal resene, and the dammar-like Borneo copal contains more resene than resin acids, yet both are readily soluble in ordinary solvents, such as 96-per-cent alcohol, ether, absolute alcohol, etc., as well as in the newer solvents, as α -dichlorhydrin, terpeneol, etc. Borneo copal is entirely soluble in carbon tetrachloride, and Manila mostly soluble in methyl-ethylacetone. For another example, genuine dammar, which has 62½ per cent of resene, is partly soluble in 96-per-cent alcohol, and quite soluble in warm ether and in ben-

zole, quickly so in α -dichlorhydrin, soluble in terpeneol, and makes a turbid solution in tetrachloride of carbon. On the other hand, Zanzibar, with only 6 per cent resene, and the West-African copals with relatively little, dissolve with the greatest difficulty and in the new and most powerful solvents only, and then only partly, as a rule. The solubility of copals does not increase with their content of resenes.

Dammar.—In the European classification dammar means a resin from Java, Sumatra, and Borneo which is obtained from a species of *Shorea*, family of *Diptocarpa*. Under the name dammar are known also numerous Indian and Malay resins which are obtained from various species of *Dammara*. Dammar is found in lumps and drop-shaped or flat pieces, grains or tears. It is found also in larger stalactitic masses, indicating that it exudes from the trees as a liquid resin and afterward hardens. The resin, the surface of which is usually smooth and shining, is transparent and generally colorless or yellowish; but there is also a dark-brown variety called black dammar. The resin of dammar (specific gravity, 1.031–1.06) is of inferior quality; the heat of the hand is sufficient to make it sticky, and when heated further it begins to melt at 75° and at 150° is thinly fluid and clear; but there are varieties of dammar which melt between 180 and 200° C.

Ethyl alcohol dissolves 71.4 per cent (according to Andés only 45 per cent), amyl alcohol 87.6 per cent, and amyl acetate about 97 per cent; it is entirely soluble in benzole, carbon bisulphide, carbon tetrachloride, monochlorbenzol, chloroform, and spirit of turpentine. Solutions in the last have a milky turbidity which can be cleared up by adding absolute alcohol. Black dammar is soluble in benzole, chloro-

form, and spirit of turpentine, and partly soluble in alcohol and ether.

Lac (Shellac).—Lac is obtained from a tree growing in the East Indies, the twigs of which are punctured by a special lacquer-making insect, which causes the secretion of lac, which is found hardened on the older twigs; it is orange-yellow, sometimes more or less dark-red. It is obtained in commerce mixed with bark and twigs. When in this condition it is called stick-lac; the resin which has been detached from the trees is known as seed-lac or grain-lac; these grades can also be made from stick-lac. Lac-dye is a dye-stuff of a red color obtained from these crude lacs. In the manufacture of shellac the easily fusible resin, which is the pure shellac, is separated from the more difficultly fusible and the impurities. Lac comes commercially in clear and dark sorts; its color is usually from light brown to deep brown-red. Its value is estimated according to the brilliancy of its coloring; that with the most intense color is most highly valued. Seed-lac is chiefly obtained as reddish-yellow grains, which often contain but little coloring-matter. Shellac comes in various grades, which are named according to color, as orange shellac, ruby shellac, etc., and is from clear yellow to brown or red-brown; it is soluble in cold alcohol with the exception of some insoluble substance known as shellac-wax; in hot alcohol the wax dissolves, but on cooling it again separates.

To remove the wax it is customary to put two parts of shellac in a solution of one part of soda in forty parts of water, and boil until the wax comes to the top; on cooling it may be removed. The liquid is filtered, then acidified, and the resin precipitates in friable lumps, which are strained off and melted to drive out the water. To make a

clear spirit varnish dissolve one part of wax-free shellac in three or four parts of alcohol (92 per cent by volume), and to this add, little by little, distilled water (one part at most) until a cheesy mass separates, and the supernatant fluid is clear; this is then filtered through paper. The residue is squeezed, agitated with alcohol, and squeezed again, and the filtrate added to the previous filtrate; then the alcohol is distilled off, leaving a pure dry resin, which is soluble in 96-per-cent alcohol. Another way is to add one part of pulverized chalk to a solution of one part shellac in six parts of 90-per-cent alcohol, and agitate well; on standing the insoluble matter settles out and is filtered off, and the residue washed with alcohol. Shellac is not entirely soluble in ether, bisulphide of carbon, or volatile oils. It is worthy of notice that at 100° C. shellac melts with a characteristic odor.

In varnish-making bleached shellac is often used. Shellac is bleached with bone-black, chloride of lime (or hypochlorite of soda), and sulphite of soda. Chiefly it is bleached with a solution made by mixing a solution of chloride of lime with soda solution, making hypochlorite of soda, which is added to alcoholic shellac solution until bleaching is effected. From this solution the resin, which is now of a very pale yellow color, is precipitated by dilute hydrochloric acid. The last trace of color is removed by boiling in water. Colorless shellac solution is especially used in lacquering metallic objects. To get rid of the final presence of a small amount of chlorine, which is often found in bleached shellac, some sulphite of soda is added before the last addition of hydrochloric acid, in order to avoid the objectionable action of chlorine. Recently endeavor has been made to avoid the expense of using alcohol, and in practice sulphuric acid is

used instead of hydrochloric. Four kg. soda is dissolved in 60 liters of water, heated to boiling, $12\frac{1}{2}$ kg. shellac added, and the boiling continued until it is dissolved; 20 liters of water and 80 liters of hypochlorite of soda are then added. This latter solution is made by dissolving 44.65 kg. chloride of lime in 80 liters of water and adding to it soda solution (50 kg. soda in 80 liters water) as long as a precipitate is formed. After settling the clear bleaching-solution is drawn off from the precipitated carbonate of calcium. After the shellac solution has been thoroughly agitated with the bleaching-solution the whole is allowed to stand (about twenty-four hours) until a tested sample shows it to be colorless. The shellac is precipitated by adding dilute sulphuric acid (2 liters sulphuric acid of 60° B \acute{e} . to 20 liters of water) until no further precipitation takes place. The precipitated resin is strained out with linen cloth or a fine sieve, and washed with water until entirely free from acid. For varnish-making it is not necessary to soften the resin in hot water and knead it into masses of a silky lustre; it is sufficient to dry it. The alcohol-solubility of white shellac becomes less by keeping; it may become insoluble. Bleached wax-free shellac makes a clear solution in alcohol; but ordinary white shellac makes a solution having a milky turbidity, which is due to the wax it contains. Bleached shellac persistently holds a little water, which may be the partial cause of turbidity. To rid the shellac of this moisture as much as possible it is ground and spread out in the air to dry for a day.

Shellac.—To remove wax from shellac, dissolve 50 lbs. shellac resin in 60 lbs. wood-alcohol. Warm it in a closed vessel (tin-lined is best—a tin can) to 120° F., then add 60 lbs. petroleum benzine, gravity 68° to 70° B \acute{e} .;

mix thoroughly and let it stand three hours at 100° to 120° F. Siphon off as much of the benzine as possible, then add 25 lbs. fresh benzine at the same temperature as before, mix thoroughly, settle for three to six hours, and draw off the benzine as before. Finally, add 15 lbs. benzine and settle over night; in the morning draw off the benzine, filter the alcoholic solution through cotton cloth (70 meshes to the linear inch), warm it to 120° F. and let it stand at the ordinary temperature about three days, then siphon off the clear solution carefully from the dregs. The yield should be 96 to 100 lbs. of clear solution, which if evaporated on a water bath leaves about 43 per cent of solids.

Grain (ethyl) alcohol is not a good solvent for this process.

On a large scale shellac-varnish is cleared of wax by slow filtration through a filter-press. The shellac is run into the press by gravity, at low pressure; it probably will not filter at all if forced in with a pump; after a little it comes out quite clear. This is a slow process, but involves very little labor, expense, or waste.

Shellac.—An interesting popular paper on the origin and preparation of shellac is to be found in *Jour. Roy. Soc. Arts*, lvii. 660, by A. F. Suter.

Further articles on shellac will be found in the appendix of this book, on analytical methods.

Mastic.—Mastic is chiefly obtained from the island of Chios, and is produced by a tree, the *Pistacia lentiscus*, L. Incisions are made in the trunk, from which the liquid resin trickles and forms spherical or tear-shaped grains; it also exudes in drops from the twigs.

Pure mastic (specific gravity 1.04 to 1.07) is that which is in tears; it comes principally in rounded pieces of the size of a pea (from 0.5 to 2.0 cm. diameter), in color pale yellow inclining to green, with an aromatic taste and, when heated, a characteristic odor. It is free from dirt and other impurities, and the dissolved pieces form a cheaper grade. The

resin is very brittle, but softens in the mouth after long chewing. An inferior grade softens at 85° to 93° C., and melts at about 103° ; the better quality softens at 99° and melts at 108° .

There is in commerce besides Chios mastic a variety called Bombay or East-Indian mastic, which is partly in grains or shapeless lumps and partly in tears like that from Chios. It is yellow to brown in color and smells like turpentine when heated. Chios mastic is partially (80 to 91 per cent) soluble in cold alcohol, wholly in boiling alcohol; the alpha-resin (mastic acid, $C_{40}H_{64}O_4$) is soluble in cold alcohol, the beta-resin (masticin, $C_{40}H_{62}O_2$) in boiling alcohol. Mastic contains also an ethereal oil. Bombay mastic is quite soluble in absolute alcohol; a film of the solution allowed to dry on glass in the air requires more than twenty-four hours to dry.

Mastic: L. E. Andés, *Rev. Fett-Harz-Ind.*, xiv. 190-191, and *C. A.*, i. 2750.

Sandarac.—This resin is obtained from a species of cypress (*Callitris quadrivalvis*), which grows in northeastern Africa; in part it exudes naturally from the bark, but is also obtained from incisions in the bark, which are made for the purpose. Sandarac occurs in elongated, small, brittle tears, having a vitreous fracture; in color it is pale yellow, yellow, and brownish. It has a characteristic odor, especially when warmed; does not soften by chewing, swells up and melts at 135° or 136° C. In 96-per-cent alcohol, ether, methyl-ethyl-ketone, and acetone it is quite soluble, and very soluble in α -dichlorhydrin and terpeneol. It is only slightly soluble in carbon tetrachloride and in benzole, and insoluble in monochlorbenzole. By the addition of 10 per

cent of absolute alcohol to a mixture of the resin with carbon tetrachloride a clear solution is obtained, and a like result is obtained with alcohol and monochlorbenzole. This last solution makes a varnish which dries with a mat surface.

Sandarac: Tschirch and Wolff, *Arch. Pharm.*, ccxlv. 684-712, and *C. A.*, i. 1165. Chemical constituents, especially acids.

Elemi.—This is a turpentine-like resin, which has a specific gravity of 1.018 to 1.083, obtained from various plants of the family of Burseracea, in Central and South America, West and East Indies, and Manila. It is at first soft and hardens by degrees; and elemi varies from a turbid, sticky, yellowish-white, thick mass, as is Manila elemi, to a solid resin, like Mexican elemi. The last has a laminated structure, a coarsely conchoidal fracture, and pale yellow color; in the air it becomes milk-white and is covered with a white crystalline powder.

Elemi consists, besides volatile oil, of two different resins, of which one is soluble in cold, the other in hot alcohol. It contains between 3.5 and 13.7 per cent of a mixture of volatile oils isomeric with spirit of turpentine. Elemi resin softens at 80° and melts at 120° C. It is partly soluble in monochlorbenzole. It is not by itself made into a varnish, but is added to a variety of spirit varnishes; it makes them less brittle and more elastic. For this the various sorts of elemi are better than turpentine, because they hold their volatile oil more tenaciously. To make varnishes elastic, elemi, castor-oil, and Venetian turpentine are melted together, and this compound is added to the solution of resin.

Elemi: A. M. Clover, *Philipp. Jour. Sci.*, ii. 1-40, and *C. A.*, i. 2158. Manila elemi is obtained from *Canarium luzonicum*, locally known as *pili*; contains 25 to 30 per cent volatile oil, constituents of which are described.

Colophony and Hardened Rosin.—It is well known that colophony or rosin is obtained from coniferous trees; turpentine, from which rosin and turpentine-oil are made, is the balsam of their resins. Rosin is highly lustrous and transparent, odorless and tasteless, and very brittle. It varies in color; it is wine-yellow, clear yellow, amber-colored, and so on to very dark brown or brown-black. The impure crude turpentine is called pitch; there are yellow, red, and black varieties. In recent years colorless, refined rosin is to be had; from America we have a commercial article that is of a beautiful clear yellow color. Colophony consists chiefly of rosin acid (abietic acid); besides there are inactive substances, proto-catechu-acid, bitter principles, and traces of mineral ingredients. Rosin melts at 120° C.; it is soluble in alcohol, ether, methyl alcohol, amyl alcohol, benzole, acetone, chloroform, carbon bisulphide and spirit of turpentine, and very soluble in petroleum ether; partly soluble in petroleum. Recently colophony has been bleached. These pale varieties are used in making varnish, and are hardened by blowing air or oxygen through the melted rosin with (or without) admixture of drying-oils, rosin-acid salts, etc.; by raising the temperature and pressure the process is made more rapid. To harden rosin it is also the practice to stir zinc oxide into the melted rosin and heat the mixture to 200° C. The acid which it contains unites chemically with the zinc oxide, and the change produces an increase of hardness. Rosin is used in making various varnishes, such as rosin-spirit varnish, rosin-asphalt varnish, etc., also book-

binders' compositions and the like. To lessen the brittleness, crude turpentine is added to rosin-varnishes, as has already been said. In bookbinders' varnish transparent rosin, rectified rosin-oil, and well-settled linseed-oil are used. Hardened rosin can be used with advantage in making varnishes. Varnish made with zinc resinate withstands atmospheric influences and is more durable than if made with common rosin.

Rosin: P. Levy, *Z. angew. Chem.*, xviii. 1739, and *Ber.*, xxxix. 3043-46, and *C. A.*, i. 54. Abietic acid, etc.

C. Schwalbe, *Wochbl. Papierfabr.*, xxxviii. 1303 (Apr., 1907), and *C. A.*, i. 2635.

Veze, *Proc. verb. soc. phys. nat.*, Bordeaux, 1905-06, p. 75, and *C. A.*, i. 2638. Manuf. of turpentine and rosin.

C. Bachem, *Arch. exp. Path. Pharm.*, lvii. 222 (1907) and *C. A.*, i. 2802. Dry distillation of rosin yields CO_2 , CO , CH_4 , N , and heavy hydrocarbons.

M. W. Shkatelov, *Mon. Sci.*, xxii. 217-227 and 548, and *C. A.*, ii. 1714 and 2872. Properties of rosins from various sources.

G. B. Frankforter, *Jour. Am. Chem. Soc.*, xxxi. 561-565. Rosin of Norway Pine. *C. A.*, iii. 1817.

See also appendix on analytical methods; also section on manufacture of rosin-varnishes.

Gum Benzoin.—This comes from Sumatra, Java, and Borneo, from a tree (*Styrax benzoin*, Dry.), which is a native of these islands and of farther India. In the market there are various sorts; benzoin in tears, almond-benzoin, block-benzoin, and Penang-benzoin. Almond benzoin is the best. In block-benzoin there are white grains enclosed in a brownish mass; in Penang-benzoin the mass (matrix) has a chocolate color. When warmed it gives off an agreeable odor; it melts at 75° to 95° C. It is soluble in alcohol, all except the impurities; in ether, volatile and fixed oils it is partly

soluble. It is composed of resinous bodies and benzoic acid; in some sorts the latter is replaced wholly or in part by cinnamic acid. It is used to impart a fragrant odor to spirit varnishes; there is also a so-called benzoin-extract, made of one part benzoin to two of absolute alcohol, by weight, with which a hard gloss can be imparted to a lacquer.

Benzoin: D. M. Figart, *U. S. Consular and Trade Reports*, 1911, p. 1148:

“Gum Benjamin,” or benzoin, is the aromatic resin of the *Styrax benzoin* of the order Styraceæ, a common tree of the Malay Peninsula and Sumatra. The Malay name of the product is keminiyan.

In trade there are two forms of the gum used, the Palembang benzoin, which is undoubtedly the product of the *Styrax benzoin*, and Siam benzoin. The latter is believed to be derived from a different species and is reported to come from Laos. Up to the present time, however, there has been obtained no botanical material enabling one to decide from what tree it is derived, although many attempts have been made to induce people living in Siam to procure specimens.

The Sumatra, or Palembang, tree inhabits dense forests at low elevations and attains a height of 60 to 80 feet or more. It has smooth gray bark, and the leaves are lanceolate, light green above, white or whitish beneath. The flowers in panicles or racemes are white and very fragrant. The fruit is globose, flattened at each end, pale grayish-green, $\frac{1}{2}$ to 1 inch across, with rather thick, hard green pulp, and two hemispheric brown seeds. The tree flowers when it is about 12 feet tall, and is worth cultivating for its fragrant and pretty blossoms.

It is very abundant in many parts of the Straits Settlements. The benzoin produced by the Malay Peninsula tree seems to be quite as good as that from Palembang, but for some reason the natives here seldom collect it. The resin does not flow readily when the tree is cut, and the bark has no scent or signs at first of it, but about a

fortnight or so after the infliction of a wound it exudes and often trickles down the bole.

The resin usually appears in the market in cubic blocks of a brown color, containing opaque yellowish-white tears or almonds, with a good deal of débris of bark and wood. The more tears in the mass the more valuable is the benzoin. The Sumatran benzoin is not valued so highly as the Siamese kind, having a less strong and pleasant odor and also being less pure. Benzoin is used in the preparation of benzoic acid, in medicine, and as a perfume.

Amber.—Amber is a resin produced by coniferous trees of a past age, which grew on land which is now under the waters of the Baltic Sea. The resin, the specific gravity of which (0.9217 to 1.085) has been diminished a little by the sea-water, is loosened by storms from the bottom of the sea and thrown upon the shore, where it is collected; it is also obtained by dredging the sand along the sea-margin, and in various places it is found by mining. It is graded according to color, purity, size and form of the pieces; it is clear sulphur-yellow, dark yellow, brown, red, blackish-brown, and white; it is transparent or clouded with white, etc. When warmed and rubbed it becomes electrified; if thrown on glowing coals it burns with a reddish, clear bright flame, and gives off an aromatic and characteristic odor. It is composed of carbon 79 parts, hydrogen and oxygen each 10.5 parts; by dry distillation it yields succinic acid, amber-oil, and water. The residue is amber-colophony; more strongly heated it is decomposed into a thickly-fluid brown benzole and amber-camphor. It is but slightly soluble in alcohol and ether; somewhat soluble in benzole, chloroform, and alcoholic solution of camphor. It is only slightly soluble in volatile and fixed oils. By Palmer's

method amber may be dissolved with only a slight loss of amber-oil, by heating it, in a glass vessel, in an oil-bath. Boiling linseed-oil softens it. As a rule melted amber is used in making amber varnishes. For this the chips and trimmings which are left in working the larger pieces, and the impure and small pieces which are got in dredging, are used.

Japanese and Chinese Lacquer.—Raw Japanese lacquer (Kiurushi) is a liquid sap of the varnish-tree (*Rhus vernicifera*, D. C.), both native and cultivated in China and Japan; it is a more or less thickly fluid emulsion, of a gray-white color. The pure Japanese lacquer, which has a specific gravity of 1.002 to 1.037, is made from the raw lacquer by a process of purification; it finally comes to market as a tawny-colored, syrupy liquid. It contains 60 to 80 per cent of acid—urushic acid, $C_{14}H_{18}O_2$ —and 10 to 34 per cent water, a kind of gum, frequently some oil, and albuminous bodies. The last-named ingredient acts as a ferment, and under its influence the lacquer hardens, the urushic acid absorbing oxygen and becoming oxy-urushic acid, $C_{14}H_{18}O_3$.

Regarding the drying of Japanese lacquer, either alone or in combination with other substances, it is to be observed that it dries quickly in a damp room, as the action of damp air on the lacquer rapidly hardens it.

Sixty to 80 per cent of Chinese or Japanese lacquer is soluble in alcohol, ether, benzole, and carbon bisulphide. Lacquer collected outside of Japan and brought to market by the Rhus Company is similar to real Japanese lacquer; both products are used in making lacquered ware, which excels all other varnished work in lustre, hardness, and resistance to high temperatures and solvents.

It seems worthy of mention that Japanese Rhus lacquer is

able to unite with caoutchouc or gutta-percha without the aid of a solvent, to make a homogeneous, quick-drying, highly lustrous lacquer.

Burmese varnish, very much like Japanese lacquer, is the subject of a valuable paper by Puran Sing, F.C.S., etc., in *Indian Forest Records*, vol. i., part 4, 1909, pp. 287-308.

Chinese and Japanese lacquer, descriptions, J. J. Quinn, *British Consular Reports*, 1882; J. J. Rein, 1889, *Industries of Japan*; Sabin, *Tech. Paint and Varnish*, 1904; Tschirch and Stevens (review of literature of subject), *Mon. Sci.*, Oct., 1906, 731-760; scientific papers, Majima and Cho, *Ber.*, xl. 4390-93; Majima, *Ber.*, xlii. 1418-23; Miyama, *J. Coll. Eng. Tokio*, iv. 89-110, 201-204, and *Chem. Rev. Fett-Harz-Ind.*, xv. 148-149.

c. Colored Resins.*—Acaroid Resins: The red variety is also called Nutt-resin, and the yellow is called Botany-bay-resin, and they are obtained from various sorts of Xanthorrhœa, belonging to the Liliacea, which are natives of continental Australia, Tasmania, and the Australian islands. A similar resin also comes from the West Indies.

The red resin is obtained in larger or smaller pieces, generally mixed with sand; they have a resinous lustre, are lumpy, brownish in color, but their fragments appear ruby-red by transmitted light. The yellow resin forms rounded or sometimes long pieces, usually colored reddish-brown, having the odor of benzoin. All the acaroid resins are soluble in alcohol. The alcoholic solutions of these resins can be used instead of shellac colored with gamboge and dragon's-blood, without other coloring-matter, to impart a fine yellow or red tone to the surface of brass-ware. The

* Seed-lac, which also belongs among these, has already been described under Shellac.

solutions of acaroid resins do not fade in the light, unlike those of gamboge and dragon's-blood.

Dragon's-blood.—It comes principally from various species of *Dæmonorops*, of the Palm family, which are natives of Farther India, Sumatra, and Molucca. It comes into the market as stick dragon's-blood, and in lumps, cakes, and tears. Dragon's-blood from India contains about 57 per cent of a red resin (dracin), with some clear yellow and a little white resin, and a remainder of vegetable matter. The best sorts have a deep red color, often blackish; the less valuable a brick-red color; the specific gravity, which is from 1.195 and 1.275, is higher in the better sorts. It melts at 70° C. and is readily soluble in alcohol; it is used only on account of its color. It is used in red spirit varnishes and polishes; especially with gamboge, mastic, elemi, sandarac, seed-lac, shellac, etc., for making gold-colored varnishes, such, for example, as are used on picture-mouldings.

Gamboge.—This resin is obtained from various species of *Garcinia* (*Guttifera*) in Farther India and the island of Ceylon. It exudes from broken twigs and leaves of the trees, as a yellowish, milky juice which hardens in the air; it is also obtained by making incisions in the tree or from the bark.

The Siamese gamboge is the most common in the European market, and is classed according to form and quality as tubular, cake and lump gamboge, and as common gamboge. The tubular contains 74 to 86 per cent, and the cake 64 to 68 per cent of resin or gamboge-yellow; there is also 15 to 27 per cent of gum, and usually about 5 per cent of water; and some mineral matter. The tubular variety comes in cylinders hollow from end to end, brittle, shining fracture, and red-yellow to clear brownish-red; on long

exposure to the air it becomes covered with a greenish-yellow to dark green layer.

Cake gamboge is in fragile, irregular pieces, with a dull glassy fracture. Gamboge dissolves readily, making a yellow-red solution, in alcohol and ether; the solution is decidedly acid. It is used as a coloring-matter in spirit varnishes; especially with dragon's-blood in making gold-lacquer.

d. Various Raw and Artificial Products.—*Natural Asphalt*: Asphalt or bitumen has a specific gravity from 1.07 to 1.110, and comes from various places, *e.g.*, from Utah, North America, Mexico, Peru, Cuba, the island of Trinidad, Syria, the Dead Sea, etc., either in beds in the earth or floating in the sea-water. It is in black, shining brittle pieces having flat conchoidal fracture, which on heating give off an unpleasant odor.

Asphalt is a solid polymeric product of the high-boiling-point petroleums, which has become oxidized and by this change become black. It melts easily (at about 80° C.), and in melting gives off a thick, heavy vapor. When ignited it burns with a red, very smoky flame, and leaves a little blackish-brown or gray ash. Inferior grades have more ash. Syrian and similar asphalts, which are easily soluble in spirit of turpentine, benzole, petroleum, and chloroform, are used in making asphaltum varnishes. It is also soluble in mono- and dichlor-benzol.

Coal-tar Pitch.—It is obtained in the distillation of coal-tar. It resembles asphaltum, and is used as a substitute for it. It is used together with natural asphaltum, ordinary resins, colophony, wax, etc., and with benzole, spirit of turpentine, linseed-oil varnish, etc., to make asphalt varnishes. Along with coal-tar pitch we may class the solid, densely

black asphaltum which is a residue from refining petroleum, which is used in place of natural asphalt. Artificial asphalts come under various names, as Gilsonite, Cuban asphalt, etc., and, as has already been said, resemble natural asphaltum in color, lustre, and hardness; they have a dull, brown, brownish-black, or black surface. (These are names of natural asphaltums, and artificial products are never sold under these names in America, whatever may be the practice in Europe.—Translator.)

Gutta-percha.—*Gutta-percha* is the dried milky juice of a tree, the *Isonandra gutta*, family Sapotea, which grows in the islands of the East Indies.

The milky juice is obtained from incisions in the trunk of the tree, and before it becomes entirely hard it is made into long pieces by the hands. The best quality is white with yellowish or reddish tinge; the poorer grades are reddish and brownish. For the most part it is a tough, fibrous mass, the average specific gravity of which is 0.975; at 25° C. it is flexible, begins to soften at 48°, and is quite plastic at 60°; at 120° melts to a thin, mobile liquid; dry distillation yields a yellowish, disagreeably smelling liquid (*gutta-percha-oil*). *Gutta-percha* is a hydrocarbon, of which the chief constituent (78 to 82 per cent) is the so-called *Gutta*, a white substance insoluble in alcohol or ether; besides which it contains 14 to 16 per cent of *Alban*, and 4 to 6 per cent of *Fluavil*, which are oxidation products from *gutta*.

Gutta-percha is easily soluble in petroleum ether, carbon bisulphide, and chloroform; it dissolves also with gentle heat in benzole, spirit of turpentine, petroleum, caoutchouc-oil, and *gutta-percha-oil*. By the evaporation of the solvent the *gutta-percha* remains as a film which is remark-

able for its resistance to chemical action and impermeability to water.

To make a gutta-percha solution of purified gum, which is prepared by precipitating it from a solution, add to the solvent, which may be bisulphide of carbon, spirit of turpentine, or the like, from 5 to 50 per cent, as may be necessary, of alcohol or wood-alcohol. This prepared solvent being ready, the gutta-percha is kneaded with a little of the chosen solvent, and then enough of the prepared mixture added to it to make a syrupy fluid, which is allowed to settle for three or four days.

If it is desired to make a varnish, such, for example, as is used on leather, one part of good dry gutta-percha is dissolved in a water-bath in eight parts of linseed-oil varnish, or in ten parts of linseed-oil; in the latter case the mixture may be heated until the gutta-percha is melted. This varnish can be colored by mineral pigments, which are to be ground in copal-varnish and added with thorough agitation to the gutta-percha solution.

Caoutchouc.—This substance, also called india-rubber and gum elastic, is the inspissated milky juice of various plants (chiefly trees), which are natives of tropical countries, especially in Brazil, Mexico, Central America, West Africa, the East Indies, and in Madagascar, Borneo, and Sumatra. It is prepared from the milky juice either by simply drying it or by various treatments. In commerce the following are the most important sorts: Para or Brazilian rubber, that from Carthagen (Colombia), West Indian or Central American rubber, African (from Gaboon, Congo, Angola, etc.), and that from Madagascar.

Rubber, according to its source and preparation, is a more or less dark-colored, tough, extremely elastic substance, with

a characteristic odor; chemically it is a terpene polymer ($C_{10}H_{16}$). Heated to 120° C., it melts, but remains, after cooling, sticky and soft, and even in thin layers dries only after a long time. In melting it gives off a peculiar odor, and on heating more strongly it burns with a bright flame.

Rubber is very indifferent to chemical action; treated with the common solvents, as ether, benzine, carbon bisulphide, and mixtures of these, it swells and partly dissolves; to completely dissolve it a large amount of solvent is necessary. The insoluble part, which is very difficult to separate, is tough, little sticky, softer, and less elastic than the other part; it contains the coloring-matter. Before dissolving india-rubber it is dried for a considerable time, being cut up into small pieces and left at 70° to 80° C. until it ceases to lose weight. Before dissolving it is also the custom to boil it with solution of carbonate or caustic soda, then thoroughly wash it and dry. If it contains moisture it is not completely soluble.

As has been said before, as a rule the solvents, which must also be absolutely free of water, dissolve rubber only partially. If it is attempted to make a perfect solution by heat it often happens that decomposition takes place; on thinning such a solution a mass separates which has not the characteristics of rubber, and, especially when dried in thin films, remains sticky. By the use of certain mixtures of solvents, as 100 parts carbon bisulphide and 6 to 8 of absolute alcohol, it can be completely dissolved, and can be made thin; a solution which by evaporation leaves films of rubber having all its recognized characteristics.

A good solvent for rubber is caoutchouc-oil, which is made by the dry distillation of rubber; next are benzole, chloro-

form, carbon bisulphide; and especially spirit of turpentine, containing 2 to 5 per cent of sulphur, is a good solvent.

Besides the ordinary rubber is hard rubber, made by chemical treatment of rubber, used for making varnish.

Ceresin.—Ceresin is a substance which looks like wax, and is obtained by refining ozokerite, a sort of natural paraffine. It is also called artificial wax, but chemically has no similarity to beeswax.

Ceresin is used for floor-wax in mixtures such as with stearine, yellow wax, potash, hard soap, water, and coloring-matter, also with paraffine-oil and lime-water, also with petroleum, spirit of turpentine, and benzine.

Wax.—Natural yellow wax (beeswax) is used largely for floor-wax, and white wax, which is bleached beeswax, for varnish used on white metal, brass, and masonry. Wax is often adulterated with vegetable substances, such as Japan wax, of wax-like properties; also with paraffine. It is only partly soluble in boiling alcohol, but completely so in warm ether, spirit of turpentine, benzine, benzole, and carbon bisulphide.

For example, a solution may be made of one part wax in two parts warm benzole; the solution (wax lacquer) may be diluted with petroleum or light oil of coal-tar; it is used on brass and white metal, although the film is not transparent and conceals the lustre of the metal. For use on masonry it is melted and dissolved in spirit of turpentine, and after cooling mixed with dammar varnish.

To make a flatting varnish one part of white wax is mixed with two parts of copal varnish, the mixture warmed and agitated, and eight parts of spirit of turpentine is gradually added with continued agitation.

Beeswax: G. Buchner, *Chem.-Ztg.*, xxxi. 126, 570, 1085, and *C. A.*, i. 1065, 2161, ii. 471; K. D. Helfenberg, *Chem.-Ztg.*, xxxi. 987; *C. A.*, ii. 192; K. Dieterich, *Pharm. Post*, xl. 639; *C. A.*, ii. 714; R. Berg, *Chem.-Ztg.*, xxxii. 777; *C. A.*, ii. 3005; U. S. Pat. 883,661, bleaching beeswax with fuller's earth.

Paraffine.—Paraffine, a mixture of many hydrocarbons, is obtained in the distillation of lignite and peat, as well as of mineral oil. It is a solid, white or yellowish, translucent, wax-like substance, which melts at 40° to 53° C. and is soluble in alcohol. It is used in lacquers to diminish their brittleness. In this way a varnish which does not admit of the addition of oil, may be made less brittle; for example, shellac varnish may receive an addition of paraffine, stearine, or spermaceti in alcohol, ether, or other solvent.

Spermaceti.—This is obtained from sperm whales (*Physeter macrocephalus*); it is found in bony cavities in their heads. It is a white, flaky, brittle mass, with a pearly lustre, soft to the touch, and melts at 38° to 47° C., according to its purity. It is used in varnishes in the manner already described; it is dissolved in alcohol, ether, or spirit of turpentine, and added to shellac varnish in the proportion of twenty to thirty parts of spermaceti to a hundred parts of shellac (or other) resin.

Camphor.—Obtained by sublimation from the wood of the camphor-tree (*Camphora officinalis*), which is cultivated in China and Japan. It is a white, lustrous, crystalline, very volatile substance, of a characteristic taste and odor. It melts at 175° C. It dissolves readily in alcohol, ether, and oils.

Borneo camphor, which comes from camphor-oil or the camphor-tree (*Dryobalanops camphora*) of Sumatra and Borneo, is similar to ordinary camphor.

Camphor is used in making celluloid and celluloid varnishes. One part of camphor in twelve parts of ether is a solvent for roasted copal. Two parts of camphor in three parts of alcohol is used as an addition to spirit varnishes to make them more elastic.

Resin Esters.—Resin esters are chiefly made from colophony, but may be from other resins, as well as solid petroleum acids, etc. Usually a resin ester is made by combining a resin acid with an alcohol, with the elimination of water. Both natural resin acids and synthetic acids may be used; the details of the methods employed cannot be given here. Some of them are soft, colorless, resin-like bodies, used as additions to the soft resins such as mastic, damar, sandarac, and the like; others are very hard resinous bodies, used with hard resins like copal and amber. They may be used like natural resins in making oleo-resinous varnishes and also as solutions in spirit of turpentine, benzine, etc.; these latter are used with additions of wax, paraffine, palmitin, linseed-oil, etc. The cooking of resin ester with linseed-oil is best conducted in closed kettles, in an atmosphere of indifferent gases, such as CO_2 , and with the addition of a small percentage of peroxides, such as PbO_2 or BaO_2 . Clear varnishes are thus made.

Nitrocellulose and Celluloid.—Cotton waste (cellulose, $(\text{C}_6\text{H}_{10}\text{O}_5)$) is treated with a mixture of nitric and sulphuric acids in nitric ester, and according to the intensity of the reaction is converted into gun-cotton, pyroxyline ($\text{C}_{12}\text{H}_{14}(\text{NO}_2)_6\text{O}_{10}$), or into dinitrocellulose. The last, commonly called nitrocellulose, is easily soluble in a mixture of ether and alcohol; this solution is called collodion. When dinitro-cellulose is mixed with camphor and heated under a high pressure to about 120°C ., it is converted into a sub-

stance called celluloid. Nitrocellulose is used in making a variety of lacquers; thus, collodion is used as an antiseptic coating, protecting the hands from infection.

The substance used to make films in dermatological practice is called "surgical skin varnish." Collodion is used for this; but mixtures are made of it with castor-oil or Canada balsam.

Bottle lacquer is made by adding to collodion 1 per cent of camphor or 2 per cent of acetone; made sufficiently thin the film is colorless and transparent, and may be colored with aniline colors so as to produce artistic effects.

Celluloid is a white, horn-like substance, soluble in alcohol and ether. To dissolve it, it is cut up into shreds and moistened with alcohol and ether, left to stand for some hours, and finally treated with the solvent. To carry this out in a small way it is necessary to put the celluloid in a well-closed vessel with a portion of solvent, let it remain at least twenty-four hours, toward the last in a water or steam bath, then add another portion of solvent, draw off that which has dissolved, add more solvent, and continue the treatment, with frequent shaking, until solution is complete. Besides alcohol and ether, celluloid is soluble in acetone, spirit of turpentine, benzine, amyl acetate, etc., either alone or in various combinations. The solvent must be free from water, or the resulting film will not dry with a bright surface. An especially useful solvent for nitrocellulose or celluloid is a mixture of alcohol and acetone, which makes lacquers suitable for a variety of uses. For making celluloid lacquer it is necessary to use either dry, hard, or spongy celluloid, and to make the solution in a thoroughly tight vessel, provided with a stirrer, and set in a steam- or hot-water bath.

The solvents used in celluloid lacquers are very volatile and inflammable, and the varnish soon closes the pores of filter-paper, so that it is impracticable to filter it; it must therefore be clear and transparent when it is made, or else left to clear itself by standing.

Celluloid lacquer, as has been said, can be made also by dissolving nitrocellulose in alcohol-ether and adding camphor to the solution. If such a solution is used as a lacquer, when the solvent has evaporated a film of celluloid is left on the coated article. Besides dinitrocellulose, in making lacquers, pyroxyline (trinitrocellulose), and tetranitrocellulose are used. Pyroxyline is used, for example, in Parisian enamel, which is made from Japan varnish, ether, methyl acetate (90 per cent), and pyroxyline. It serves as a substitute for enamel, both transparent and opaque, on bronze, wood, paper, etc. For decorative work it may be colored with aniline dyestuffs, soluble in the lacquer. Such a colored lacquer, according to de la Grange, is made of tetranitrocellulose, amyl acetate, alcohol, castor-oil, and coloring-matter.

Pyroxyline: G. Lunge, *Z. angew. Chem.*, xxix. 2051-58. Review of work since 1899. Abstract by C. E. Munroe in *C. A.*, i. 908.

It is worthy of note that within a few years cellulose acetate has come into commercial use; its special merit is that it is non-inflammable. It is therefore suited for films for moving-pictures, where the use of pyroxyline films introduces a serious danger of fire; it is also said to make a better insulating coating for small wire. It is soluble in certain organic solvents; but its cost is much greater than that of pyroxyline, and it is not likely to displace the latter for ordinary use.

A new (1911) book, *Nitrocellulose Industry*, by E. C. Worden, two volumes, is a well-written and apparently

exhaustive treatise on the entire subject of cellulose solutions and their products.

2. DRYING-OILS

Linseed-oil.—Linseed-oil is the most important of the drying-oils. It is made from the seed of the flax plant (*Linum usitatissimum*) which is grown in large quantities in Europe, on land suited to it. Flaxseed (linseed) contains over 60 per cent of oil, of which we obtain 21 to 22 per cent by cold pressing, and up to 28 per cent by hot pressing. The best oil is made by cold pressing (ordinary temperature); but good oil is also produced when the seed is heated in pressing to about 90° C., but not quite equal to cold-pressed oil. Of late years it has also been made by a process of extraction with carbon bisulphide or petroleum ether, which after extraction is distilled off, leaving the oil as a residue.

Linseed-oil. Yield: The statement by Professor Bottler is probably a clerical error. The actual percentage of oil in North-American flaxseed is said by Ennis to be 38, and the amount obtained is over 33 per cent. South-American seed may run as low as 37 per cent and Calcutta as high as 42 per cent. The actual yield is 32 to 33 per cent.

It is remarkable that L. E. Andés, who certainly is experienced in using oil, says that the seed contains about 33 per cent of oil, of which approximately 26 per cent is technically extracted. He quotes Chevallier and Lassaigue as giving European seed percentages of oil from 29 to 39 per cent. Possibly these figures are in part based on commercial seed including impurities, which Andés says run often to 20 per cent and sometimes higher.

In the laboratory of the National Lead Company the following figures have been obtained, which are based on clean whole seed, picked over by hand; there was a

single sample of Russian (Kertch) seed, and the other figures are averages of a large number of lots of North American, La Plata (Argentine), and Calcutta seed.

	Oil, Per cent.	Specific Gravity of Seed. $\frac{15^{\circ}}{15^{\circ}}$	Average Weight per Seed. Milli- grammes.	Oleaginous Im- purities. Per cent.	Non- oleaginous Impurities Per cent.	Oil in Total Impurities Per cent.
N. American	39.69	1.1388	4.61	1.50	1.69	10.0
La Plata....	36.98	1.1415	5.58	0.58	5.64	14.1
Calcutta....	40.82	1.1326	5.41	4.85	5.03	14.9
Russian	39.11	1.1375	5.74	5.05

In addition to these a sample of Bombay seed recently examined gave oil, 41.23 per cent, wt. per seed, 7.92; and a sample of Turkish seed gave oil, 43.01 per cent, wt. per seed, 7.45.

The oil in all cases was extracted in the laboratory with solvents. The oil extracted from an accumulated lot of impurities of La Plata seed recently, was dark green in color, had an iodine no. (Hanus) of 160, and was not much better drying than cotton-oil. It is not the belief of the writer that an appreciable amount of oil is expressed from impurities. These impurities are largely chaff, and absorb oil rather than give it up. In a powerful and efficient laboratory press it is impossible to express oil from the impurities which have been removed from the seed. If oil is made by extraction (percolation) probably a little of this oil is mixed with the flaxseed-oil; but if its iodine no. is as high as has been noted, it would not affect the constants of the oil appreciably. The oil-constants will be mentioned under analytical methods.

Cold-pressed oil is of a very clear yellow color, with a faint but characteristic odor and taste. Compared with this the warm-pressed oil is darker in color, and the taste and odor stronger and less agreeable. The specific gravity varies according to age of the oil; according to Schubler it is about 0.9347 at 15° C. At the same temperature the

viscosity is 9.7 and at $7\frac{1}{2}^{\circ}$ C. is 11.5. It thickens decidedly at -16° C., and at about -29° C. solidifies to a solid yellow substance. When heated it gives off a vapor; Kunkler gives 185° C. as the point at which this begins, and the flash-point at 285° C. In burning it gives off much smoke. It contains about 80 per cent of glycerides of linoleic, linolenic, and isolinolenic acids, in addition to which there is a mixture of glycerides of oleic and solid fatty acids. On drying by the action of the air a glyceride of oxylinoleic acid (oxylinoleine) is formed.

Because of its yellow coloring-matter it is impossible to make colorless varnish of ordinary linseed-oil; and the less color a varnish has the more valuable it is; so that attempts have been made to bleach linseed-oil in various ways. If ten parts (by weight) of sulphate of iron (ferrous sulphate) is dissolved in sixteen parts of water, and the solution added to ten parts of linseed-oil in a clear glass flask, and this, with frequent shaking, kept in the direct sunlight four to six weeks, the oil will be completely bleached. The colorless, thinly fluid oil is carefully poured or siphoned off from the iron-sulphate solution, which can be used only once. Linseed-oil is also bleached with lead sulphate, a white, insoluble powder, which is thoroughly ground with some of the oil and the remainder of the oil added to it, with agitation, enough lead sulphate being used to make a milky mixture. This is put in a glass flask and kept in the direct sunlight for a week, with frequent shaking. On settling, there is at the bottom a layer of lead sulphate and over this an apparently solid leathery mass, from which the bleached oil may be poured off. To 100 parts of oil 2 parts of lead sulphate are used. Linseed-oil is also bleached with sulphuric acid; this is the ordinary method in white-lead

factories. A good way to bleach oil, say 100 kg., is to dissolve $1\frac{1}{2}$ kg. chloride of lime in 25 kg. water; pour the oil in a thin stream into the solution contained in a vessel which is provided with a stirrer and be sure to keep the agitator in operation for six hours. When it has settled the bleached oil is drawn off and washed with water to remove all traces of the chloride of lime. Linseed-oil may at the same time be bleached and thickened by lead powder, which is precipitated from lead-acetate solution by strips of sheet zinc; it is treated with this for four days and then put in the direct sunlight in shallow sheet-metal vessels. The lead powder must be thoroughly mixed with the oil by stirring or shaking. After a time the oil clears itself by the separation of foreign matters; it is then filtered off and put in the flat trays aforementioned in layers two or three centimetres thick and exposed to the sun three or four days. To remove dust which may have fallen in, the bleached and thickened oil is again filtered. The lead powder may be washed with spirit of turpentine and dried; it may be used a second time. For 100 parts of oil use $1\frac{1}{2}$ parts lead powder. Recently not only raw oil but also solutions of amber and other resins in spirit of turpentine are bleached in these flat trays by agitating it with air saturated with ozone; or, more recently still, by causing such air to bubble through the oil contained in tall slender vessels. After this treatment the oil or varnish is exposed to the sun for a day in shallow layers. Linseed-oil and also spirit of turpentine rapidly absorb so much oxygen as to cause them to resinify. According to Fox, one gramme linseed-oil will absorb from 101 to 156 c.cm. oxygen; oil made from Baltic seed takes up the least (101 c.cm.) and that from American seed the most (156 c.cm.).

As has been said, linseed-oil exposed in thin layers to the air dries by the absorption of oxygen, whereby its acids are converted into oxyacids. By heating drying-oils and agitating them with air, also by warming them with various chemical reagents, which will be described hereafter, their rate of drying may be increased.

Drying of Linseed-oil: The drying of linseed-oil affords some problems which are as yet unsettled. Certain anomalous results have been from time to time recorded by various observers; but the general opinion has been that the oil absorbs oxygen, when spread out in a thin film, to the amount of 16 to 20 per cent of its own weight; that this produces certain oxidation products which are solid, insoluble in all ordinary solvents, and extremely permanent and inert. Various observers have, however, noticed that these films in some cases have lost in weight; and in 1910 the writer carried on a somewhat extensive series of experiments (*Jour. Ind. and Eng. Chem.*, vol. iii., p. 84) in which it appeared that raw oil (meaning oil which contains no driers, and is just as it came from the oil-press except that it was settled and filtered) increases in weight, slowly for a day or two, then more rapidly, and in about six days reaches a maximum of gain in weight, amounting to from 14 to 18 per cent. Immediately thereafter it begins to lose in weight; slowly the first day, then more rapidly for a few days, then slowly but continuously for some weeks, then more and more slowly, until at the end of eight or nine months it loses all the original gain, and actually weighs less than when fresh. This has been repeated so often that it may be taken to be true in general, and may be considered as a very crude outline of the facts.

Any one who has entered a freshly-painted room must have noticed an odor, pungent and unpleasant, and the presence of a gas or vapor which is irritating to the eyes and nostrils. Obviously, this cannot be due merely to the removal of oxygen from the air, but is caused by something which is given off by the paint; in fact, by the

oil. It is not turpentine, for it is present when no turpentine has been used. It is not necessary to wait until the paint is dry, for it is present before that time. Clearly, then, the first thing we ought to have recorded about the drying of oil is that it gives off something, not that it absorbs something; the latter we cannot tell without costly apparatus. Apparently the oil evaporates to dryness; and this is probably why it is called a drying-oil; but this side of the matter has not been properly considered by chemists.

If it gives off something it must lose weight; but it increases in weight. If it increases in weight it must take on something, and that something has been proved to be oxygen. Putting these facts together, it is clear that it is at the same time gaining and losing, but the gains outweigh the losses; the most obvious and likely explanation is that it absorbs oxygen, the greater part of which forms stable and finally solid compounds, and part forms volatile compounds, which go off; and the net gain in weight at any time of weighing is the difference between gain and loss. This condition of things lasts for about a week; then the formation of stable or solid compounds becomes less than that of volatile compounds, and loss of weight ensues. Note that it is not claimed that the formation of solid oxidized products ceases; but only that it becomes less than that of volatile matters. It would seem reasonable to suppose that there may come a time when the formation of solid oxidized bodies may entirely cease; while it is also possible that a process of peroxidation, resulting in a loss of substance, may go on as long as there is anything left. However, as a matter of fact, when the maximum net gain in weight is reached, the film, though moderately firm to the touch, is not properly hardened, and it continues to harden for a long time; and that it continues to absorb oxygen and form gain-producing substance is shown by an experiment which was at first the result of accident.

Early in 1911, during the winter, a set of oil-films were prepared by spreading oil on glass plates, and exposed to oxidation, with suitable care to admit air and exclude dust, in an artificially heated room, at ordinary tempera-

tures; and were weighed daily. These films gained in weight as has been described; then began to lose, and after the net losses had become fairly steady and uniform it happened that one cold day in February through some accident to the heating-apparatus the room was much colder than usual for nearly a whole day and night; though considerably above the freezing-point of water. On this cold day the weights, which had been constantly decreasing, suddenly increased; and this was true of all the films without regard to age. Next day, with normal temperature, they again began to lose; not suddenly, as had been the increase, but slowly, as they were doing before the cold day. Apparently the gain in weight was going on regularly, and the drop in temperature did not entirely stop it, perhaps did not lessen it; but the peroxidation process was greatly diminished, if not entirely stopped, by the cold. Thus it seems probable that for a long time gains and losses continue, concurrently though not at equal rate.

Let us now go back to the beginning, where it is said that the net gains amount to from 14 to 18 per cent. In fact, the writer has noted gains of over 19 per cent, and competent observers have recorded gains considerably above 20 per cent. Why should there be a difference of 30 to 50 per cent in these gains, especially if, as in the writer's case, the oil all came out of the same bottle? Such differences, even with the small films necessary to use on an accurate balance, amount to some hundreds of milligrammes, and are too great to be within any reasonable limits of error. As a matter of fact, there is no error about it.

In the first place, greater or less thickness of film makes a difference. If the film is very thin the gain will be greater and the subsequent loss more rapid than with a thicker film. Not only so, the total loss, per cent, is greater; at least that is my conclusion after a year and a quarter; what it may prove to be in the end is unknown.

Second, the influence of temperature, which must be considerable; but is not definitely known. I have observed in the winter that if the films of oil are placed so

that they are in air heated to 20° or 25° F. above the ordinary room-temperature these changes go on much more rapidly; however, in hot summer weather this does not seem to be true; so it may be that it is owing rather to the apparent dryness of the air in winter. It is known that paint dries very slowly in winter, out of doors, when the temperature is below freezing.

Third, the effect of moisture. About this still less is known, but excessive moisture in the air retards drying. Why this should be so is not clear; there is as much oxygen present as ever; it appears to me that in the damp air we have on the sea-coast in summer oil-films do not reach as high a maximum weight, nor as low a minimum; also that in damp air the dried film is less firm and hard. This may be one reason for the fact that paint is less durable near the seashore than it is in the interior.

The drying of oil is hastened by the presence of lead or manganese, in solution, in the oil. Nickel, cobalt, and iron act in the same way, but lead and manganese are commonly used; these are called driers. They appear to act catalytically; they absorb oxygen from the air and give it up to the oil, thus acting continuously as carriers of oxygen. One-tenth of 1 per cent of manganese in oil will hasten its drying from days to hours; lead is not quite so active, probably because of its higher atomic weight. It would seem reasonable to expect a more rapid and greater increase of weight of oil when these are used; but such is not the fact. The film does indeed become dry within a day; but at that time the increase in weight is inconsiderable, and this increase goes on for several days, as in the case of raw oil, but never is more than 13 to 15 per cent. Then the weight decreases, as it does with raw oil. The film is much harder and firmer than a raw-oil film. Probably the presence of driers induces more rapid oxidation processes, and especially those of peroxidation, which keep down the weight.

We will probably learn much more about these matters by constructing an apparatus in which to dry oil-films, which shall provide for the collection and analysis of all the gases which are given off. This is not a simple matter since it involves handling a great quantity of air, day

and night, for months continually. We may, however, know something about them by examining the vapors which arise; these are known to contain carbonic, formic, and acetic acids, traces of formaldehyde (which is doubtless a secondary product), and other complex organic substances.

In the opinion of the writer, oil-films, for study, should be less than $\frac{1}{1000}$ of an inch and more than $\frac{1}{2000}$ of an inch thick; $\frac{1}{1500}$ is a desirable thickness. A gallon equals 231 cu. in.; if we spread this over 2,310 sq. ft., which is about what oil without pigment naturally covers when brushed out in the usual way, 1 cu. in. covers 10 sq. ft. or 1,440 sq. in.; and its thickness is $\frac{1}{1440}$ (or about $\frac{1}{1500}$) of an inch. If it is put on as thick as $\frac{1}{1000}$, the gallon covers about 1,600 sq. ft., and if $\frac{1}{2000}$, it will cover over 3,000 sq. ft. and these are the practical working limits for brushed-out films of raw oil.

If the film is brushed out at the rate of a gallon to less than 1,800 sq. ft. I have found that it does not in early drying attain as great a weight, and in the late stages does not lose as much, and, what is of more account, shows more irregularities and apparent inconsistencies, than if at the rate of 2,000 to 3,000 sq. ft.

I have found that glass plates, 5 x 7 inches, such as are used for photographic negatives, are convenient in size; this is about the largest size for which we can easily get a sufficiently sensitive balance. Such plates weigh from 60 to 100 grammes, averaging about 75; their specific gravity is about 2.5; but no two plates are alike in specific gravity. As it is desirable to know the specific gravity of the dry film, it is necessary to record the weight in water of the clean plate; and it is much easier to get this if the experimenter will at first drill a small hole within half an inch of the edge of the plate, at the middle of one end of the same. It may also save trouble if with a file he rounds the corners of the plate slightly, to avoid danger of chipping. Having then recorded the weight of the plate in air and water, he may, with a small brush, apply oil to the middle of one side, taking care not to let it come nearer than half or a quarter of an inch to the edge; because he must handle the plate by the edges many times.

The plate should have been cleaned before the oil is applied; after it is optically clean let it soak in nitric acid, and wash with clear water; get no finger-marks on it. If not properly clean, it will sometimes happen that a week or so later the oil will leave portions of the surface, and gather in drops; which is very annoying.

To get a film $\frac{1}{1500}$ inch thick on a surface 4 x 6 inches requires 250 milligrammes of oil. This is a reasonable quantity to weigh, and with a good balance the plate which weighs not over 100 grammes may be easily and quickly weighed to one-quarter of a milligramme, which is 0.1 per cent of the weight of the oil; and that is within the limit of error. As the film does not change in weight the first day, it is easily weighed. Be very particular to get the film smooth and of even thickness; minute air-bubbles will usually disappear. If too thick, take off some with the brush, and weigh again. Have nearly the same amount of oil on plates which are intended to be duplicates, or they cannot be compared; and always have duplicates, for accidents are sure to happen. Before numbering the plates, which is done with a diamond or otherwise before cleaning, weigh the plates roughly and number them in the order of their weight, beginning with the lightest; this will save much time in the frequent weighing to be done later.

Until the films have begun to harden, it is important that they should be level, otherwise the oil will run to one corner and make a pool, and this is difficult and often impossible to remedy. It is not safe to stand them on edge for a long time.

Other things besides thickness of film, heat, and moisture affect the drying of oil. Light is well known to have an influence, particularly the direct rays of the sun. Ozone also causes more rapid oxidation; and it is said that ultra-violet rays have a powerful effect; but attempts to utilize these last two agencies have not been practically successful. Some experiments of a quantitative sort on the action of light are given by T. A. Davidson in the Papers of the Paint and Varnish Society for 1908-09. Mr. Davidson's papers in this and the following volume on the action of driers are worth careful study. In the second

volume, p. 110, he describes experiments which show that the volatile products given off during the drying of oil, already described, act as driers to films of fresh oil; and suggests that such compounds formed in oil-boiling and remaining dissolved in the oil act as driers, especially in oil cooked without driers.

Poppy-oil.—It is made by pressing the seeds of the poppy (*Papaver somniferum*). Black poppy-seed is so rich in oil that it will yield half its weight of oil.

Pure poppy-oil is colorless or pale yellow and clear; specific gravity, 0.9249 at 15° C. Cooled to -18° C. it becomes a solid and remains so until the temperature rises to -2°. One part of poppy-oil dissolves in twenty-eight parts of cold or six parts of boiling alcohol; in ether in all proportions. It is fatter than linseed, and is used only in fine varnishes.

Castor-oil.—Castor-oil is made from the seeds of *Ricinus communis*. It is colorless or greenish-yellow, transparent and viscous; in the cold, below 0°, it becomes a white, stearine-like fat, and at -17° C. solidifies into a yellowish, translucent mass. Its specific gravity is between 0.95 and 0.97; with pure oil at 15° C. it is 0.9611. In the air it becomes rancid, thick, and in thin layers dries very slowly. At 25° it mixes in all proportions with alcohol; it also makes clear mixtures with absolute alcohol, ether, amyl alcohol, benzole, and chloroform. It makes a cloudy mixture with petroleum benzine, which on standing separates into two layers.

Castor-oil is used as an ingredient for "artificial skin" varnishes, such as one composed of shellac 1 part, alcohol 3 parts, castor-oil $\frac{1}{5}$ part; or another, 8 parts collodion to 1 part castor-oil; it is also used in retouching-varnishes and negative varnishes in photography.

To give elasticity to spirit varnishes, it is thinned with alcohol to the consistency of the varnish and added to it.

Wood-oil.—Tung-oil, also known as Chinese wood-oil, is made from the fruit of *Aleurites cordata*, a tree growing in Japan, China, and Cochin-China. In its natural state wood-oil dries with a flat or non-lustrous surface, and the resultant film shows a tendency to peel. Wood-oil gelatinizes at a comparatively low temperature, and must be properly treated before use in making lacquers and varnishes.

It is heated in an enamelled kettle for two hours at 170° C. (338° F.), and is then left two days to stand and clear. The cleared oil is heated one hour at 180° C. (356° F.), which thickens it somewhat; it is then cooled to 130° C. (266° F.), and 2 per cent of pulverized litharge is added to it. Further heating is unnecessary, and it may be thinned with spirit of turpentine to varnish consistency. To tell how much turpentine is necessary, a measured sample of the treated oil is mixed with a known quantity of spirit of turpentine. When the proper amount is thus determined, the whole of the oil is thinned in proportion and allowed to stand a sufficient time to clear itself. By this treatment it becomes like linseed-oil varnish (floor varnish), and if ground with a pigment dries hard in five or six hours. Wood-oil, if heated above 200° C. (392° F.), gelatinizes and becomes a rubber-like mass, which is insoluble; this may, however, be melted and dissolved by adding to it about an equal amount of poppy or walnut oil, and heating the mixture, which makes a thick compound, soluble in benzole, spirit of turpentine, benzine, etc., but the gelatinized wood-oil cannot be used by itself, being insoluble, and will not serve in varnish-making. If wood-oil

is combined with rosin, Venetian turpentine, pitch, rosin ester, coal-tar, asphalt, or similar things, and then treated with chloride of sulphur, the resulting compound is soluble in the ordinary varnish solvents. For example, 5 parts wood-oil and 5 parts colophony may be melted together, then 1 part chloride of sulphur added, and heated to 100° C. for some time; wash the product with hot water; the compound will dissolve in one or another of the solvents.

It has lately been found that the free fatty acids of wood-oil may be used in varnish-making. These acids, which are obtained by saponifying the oil, are a solid, yellow or brown substance, and will dissolve the hardest resins; these are powdered and heated with the free fatty acids, which have been dried so as to be free of water, to above 280° C. (536° F.), and thus a solution is formed which will mix with any drying-oil, or with spirit of turpentine, etc., and the resulting varnish dries properly and forms a good film.

Hemp-seed-oil. — Made from hemp-seed (*Cannabis sativa*) by hot or cold pressing. When fresh it is yellowish-green, but darkens with age, becoming brown. It is not equal to linseed-oil in its drying quality, and on account of its color can only be used in making dark-colored varnishes.

Walnut-oil.—This is made by cold or warm pressing from walnuts, the fruit of *Juglans regia*. Cold-pressed oil is commonly made, which is quite colorless or has a very pale yellowish-green color, and has an agreeable taste and odor. Hot-pressed oil is dark and ill-smelling. Cold-pressed oil bleaches in sunlight quickly and completely; because of its color it is used in fine varnishes.

SPIRIT OF TURPENTINE AND OTHER VOLATILE SOLVENTS

Spirit of Turpentine.—Natural turpentine is obtained as an exudation from wounds in the trunks of coniferous trees, such as firs, pines, and larches; it is distilled in suitable apparatus, and the distillate is spirit or oil of turpentine, which when pure is a clear, water-white, mobile fluid, somewhat anæsthetic, with a not unpleasant odor, boiling at 155° to 163° C. Notwithstanding its high boiling-point it is very volatile at ordinary temperatures.

Of the three sorts of oil of turpentine, Austrian, French, and American, the first has a specific gravity of 0.866, the second 0.859 to 0.876, and the third 0.858 to 0.877. On account of its being so volatile and its inclination to absorb oxygen from the air and partly resinify, it must be kept in well-made closed tanks. Oxygen absorbed by turpentine is easily transferred to other substances, so that this liquid acts in varnishes not only as a solvent but as an oxidizing agent. Rosin spirit and other turpentine substitutes are different from true oil of turpentine in this respect; they do not act as oxidizing agents, but promote the drying of varnish only by their greater or less volatility.

Turpentine is an essential oil, a hydrocarbon, of which the most important ingredient is pinene, $C_{10}H_{16}$. As has already been said, in the presence of a large supply of air it absorbs oxygen and becomes viscous; on this account it acts as a reducing and bleaching agent, and in certain conditions its action goes on with the production of ozone. It is inflammable and burns with a red, smoky flame. Its vapor is also inflammable and if mixed with air is explosive. It is, therefore, important that a flame should not be used in lighting a room in which it is kept.

In strong alcohol it is soluble in about the proportion of 1 part of turpentine to 3 of alcohol; it is soluble in ether, carbon bisulphide, benzine, benzole, and fixed oils. Rectified turpentine, which has been purified by redistillation, is in general a good solvent for resins. It is used in making turpentine-oil varnishes.

It is well known that the essential oil of turpentine, or spirit of turpentine, is obtained by distillation of the crude turpentine of various species of pine; the principal one being the American long-leaf pine of the Southern States. The residue in the still is colophony or rosin. The fact that a solution of rosin in spirit of turpentine does not produce the original crude turpentine suggests that chemical as well as physical action takes place; and it is the opinion of some experienced chemists that the rosin is a decomposition product. The fact that pine wood has not the well-known pungent smell of turpentine is explained by the theory that the real spirit, in its natural state, has very little odor; it is said that if we scrape the fresh colorless pitch off the end of a recently-cut log, and immediately put it in a glass flask and heat it, we get a spirit or essential oil of turpentine with only a faint, agreeable odor. The pungent odor of ordinary spirit is thought to be due to the pitch lying long in contact with the wood and bark, and undergoing oxidation in this environment; it absorbs and develops compounds other than pinene and its allied substances, and these oxidation products produce the familiar odor. It is certain that turpentines from various trees have various odors; and that the odor does not bear any definite relation to the solvent power.

The growing scarcity of ordinary turpentine has awakened interest in its production from neglected sources; the most important being the manufacture of turpentine from the wood of pine-trees, which is reduced to chips and distilled in a current of steam. Although the boiling-point of turpentine is much higher than that of water, it readily distils in a current of steam. It may

also be made by dry distillation, but has a disagreeable odor which seriously interferes with its use. The steam-distilled product has usually a peculiar odor; but it is not disagreeable; and the spirit thus produced has equal value with the "orchard" turpentine in every other way. In fact, some of the wood-turpentines are better solvents than the standard products. There is no ground for prejudice against them, and, in fact, there is but little, and it is becoming less.

The different substances which form the group which make the turpentines differ among themselves in their effect on polarized light; some rotate to the right, others to the left; so we have dextro- and lævo-rotary turpentines and those in which these are so mixed as to be neutral and show no effect. The refractometer gives more uniform results; but the most generally accepted test is polymerization with sulphuric acid; the turpentines polymerize, the coal-tar and petroleum products do so little if at all.

Besides its great solvent powers, spirit of turpentine is valuable because of its slowness of evaporation; which gives time for the artisan or the artist to apply his material with that deliberation which is inseparable from proper care. In general, other powerful solvents evaporate too rapidly; while those which evaporate slowly are not sufficiently good solvents.

The chief substitutes for turpentine are the light mineral oils, commonly known as benzines. A few years ago the standard benzine known in the paint and varnish trade was 62° benzine; *i.e.*, its gravity was 62° Beaumé. This evaporated rapidly, and was not a very powerful solvent. Recently, some of these mineral turpentines have been made which are about as heavy as real turpentine and evaporate as slowly; and while their solvent power will not bear comparison with that of turpentine, they are much better in that respect than the old 62° benzine. As a matter of fact, it is generally true of the solvents for oils and resins, that the heavier members of a group are more effective than the lighter ones. Turpentine is easily king among these oleoresin solvents; for it exercises solvent action on almost everything in the

group of oils and resins; consequently, when it evaporates it does not precipitate some one of them out of a solution or weak compound, but leaves them all gradually without disturbing their mutual relations as the lighter benzenes are likely to do. It will be a sad day when it becomes so scarce that we can not afford its use in varnishes.

On the other hand, it is common to use a portion of turpentine as a solvent, and supplement it with mineral turpentine as a thinner; and if the latter has a convenient rate of evaporation, this is a perfectly proper thing to do. The exact limit of the amount which may be used is, however, not easily determined.

Turpentine is used as a thinner in mixing paint. Paint consists, generally, of pigment and fixed oil (linseed-oil) and to get the best results a certain amount of each must be used. Sometimes it will happen that such a mixture is too thick or viscid; in which case a volatile thinner may be used as a mechanical aid in its application. It would seem that here is a case where a mineral turpentine is equally good as the genuine; but sometimes we need the solvent action of the latter to penetrate the more or less resinous surface of the wood to which the paint is applied, and enable the latter to secure a better adhesion. There is no general rule; different cases must be considered on their merits.

Rosin-oil.—Rosin-oil varies from a thin fluid to one thick as syrup, and variously colored. For lacquers and varnishes an oxidized clear oil is made, by distilling clear rosin and separating the first which distils off (which is pinolin), and the last portion, and oxidizing with air the middle portion. The oil so made is not like ordinary rosin-oil; it is viscous, has a pleasant smell like molasses, a clear brown color, and is without bloom. According to Rénard rosin-oil free from rosin-acids consists approximately of three constituents: 80 per cent of diterebentyl, $C_{20}H_{30}$, 10 per cent of diterebentylene, $C_{20}H_{28}$, and 10 per cent of didecen, $C_{20}H_{36}$.

Rosin-oil may be purified in the following manner: In the open air it is cooked without stirring in an enamelled kettle with 3 per cent litharge, 20 per cent kaolin or clay, and 1 per cent manganese peroxide; the fire is then extinguished and the oil allowed to stand twenty-four hours to settle. The oil is then drawn off from the foots and filtered, and the residue is pressed. So treated the oil dries better than before, and is used in making varnish.

To make clear yellow rosin-oil, it must be redistilled before oxidizing it. If rosin-oil varnish and linseed-oil varnish are spread side by side on a glass plate, they will dry in the same time. It makes a glossy, hard, inelastic film which stands the weather well. It is advantageous to add to oxidized rosin-oil about 10 per cent spirit of turpentine or 20 per cent linseed-oil varnish, which increases its good qualities.

Rosin Oil: M. Utz, *Mon. Sci.*, Oct., 1906, 761-763. Indices of refraction of natural oils and of oils treated with H_2SO_4 . F. Schultz, *Rev. Fett-Harz-Ind.*, xvi. 186-189, and *C. A.*, iii. 2512. Results of fractional distillation of rosin and chemical description of the products.

Benzine and Benzole.—Benzine or naphtha is a distillation-product from American crude petroleum, obtained in refining the latter. It is water-white, mobile, inflammable, has a characteristic odor, and is very volatile. Its boiling-point is usually below $60^\circ C$. On account of its extreme inflammability the utmost care must be taken against fire, and it must be stored in well-closed vessels. Benzine is a good solvent for resins; but the solutions dry so quickly after being spread, that it is necessary to add some petroleum, turpentine-oil, or alcohol. Benzole or coal-tar naphtha is the portion which is boiled off from coal-tar oil

at 80° to 85° C. It is a colorless, strongly smelling fluid, specific gravity at 15° is 0.8841, which solidifies at 0° and boils at 80° C.

It inflames easily and burns with a luminous, smoky flame; it mixes with alcohol and ether and dissolves caoutchouc, resins, and fats easily. Benzole and benzine are used in varnishes for like uses, but benzine is used more because cheaper than benzole; benzole is a somewhat better solvent, and its solutions clear more rapidly.

Light and heavy coal-tar naphthas are known in the trade, but only the former are used in varnish-making. As has been said about benzine, this liquid is so volatile and inflammable, and its vapor so readily makes an explosive mixture with air, that the utmost care must be taken against fire.

Benzine: W. Witt, *Farben Ztg.*, xiv. 47, *C. A.*, iii. 3009. Turpentine substitutes must have boiling-point 130° – 180° C.; leave no residue on evaporation; readily dissolve resins and linseed-oil or wood-oil; flash-point not below 21° C.; odor pleasant.

L. E. Andés, *Rev. Fett-Harz-Ind.*, xvi. 248–249, *C. A.*, iii. 3009. Substantially the same as the preceding.

Benzine is a good solvent for common rosin, and no doubt dissolves some other resinous bodies; but can hardly be said to be a solvent for varnish resins. It is a good solvent for oils, in general.

Benzole is a much more powerful solvent than benzine, having considerable solvent action on many resins, and dissolving partly dried oil and varnish films. It is used to some extent in paint as an ingredient of primary coats, to soften and penetrate resinous surfaces of wood. Benzole is also known by its chemical name, benzene.

Monochlorobenzol and Dichlorobenzol.—There have recently come into use benzole products, monochlorobenzol,

C_6H_5Cl , and dichlorobenzol, $C_6H_4Cl_2$, which are water-white liquids with characteristic odor, and evaporate without leaving a residue. The first is a more mobile fluid than the other; both mix with drying-oils, spirit of turpentine, and rosin-spirit. They are hardly inflammable. They are used in making mat varnishes. Mastic, thick turpentine, colophony, asphalt, and damar, for example, are soluble in monochlorobenzol, while sandarac, shellac, manila, acaroid, and benzoin resins are insoluble; these latter resins dissolve in a mixture of this solvent with alcohol to make clear solutions, which dry flat and are used as mat varnishes. Dichlorobenzol is not used for this purpose.

Alcohol.—Ethyl alcohol, C_2H_5OH , is formed in the spiritous fermentation of sugar, which yields 94 to 95 per cent of alcohol and carbonic acid. The chief by-products are glycerine, $C_3H_8O_3$ ($2\frac{1}{2}$ to 3 per cent), and succinic acid, $C_4H_6O_4$ (0.4 to 0.7 per cent); besides which are some of the higher alcohols, as fusel-oil, of which the chief part is amyl alcohol, $C_5H_{11}OH$; it is not fully known what are the conditions which promote their formation.

Pure alcohol is a colorless, mobile fluid, of a weak, characteristic odor, unlike fusel-oil. Its specific gravity at $15^\circ C.$ is 0.7939, boiling-point $78.3^\circ C.$ It burns with a scarcely luminous flame. It is very hygroscopic and mixes with water, and with ether, in every proportion. It is easily oxidized, first to aldehyde and then to acetic acid.

Commercial alcohol always contains some water. Most of its water may be removed by anhydrous copper sulphate or anhydrous carbonate of potassium; if it is then distilled from quick-lime absolute alcohol is obtained. Hydrated alcohol is made turbid by adding benzole or carbon bisulphide. When alcohol and water are mixed contraction occurs;

53.9 parts of alcohol and 49.8 parts of water yield 100 parts of mixture, instead of 103.7 parts. The amount of absolute alcohol in a given sample of commercial alcohol is determined from its specific gravity by the aid of a table of percentages, or by using a specially constructed hydrometer (alcoholometer), which shows percentage of alcohol in degrees of immersion. The accuracy of these instruments is determined and guaranteed by the maker.

Alcohol is a solvent suitable for many organic compounds; it readily dissolves oils and resins; the latter are precipitated by the addition of water. For making lacquers and varnishes it should contain at least 90 per cent of actual alcohol. Usually in practice a kilogramme of alcohol is reckoned a litre; really it is a little more, since alcohol is lighter than water. For example, a litre of 80-per-cent alcohol weighs 863.9 grammes; of 85-per-cent, 849.6 gm.; of 90-per-cent, 833.9 gm.; of 95-per-cent, 816.4 gm.; 99-per-cent, 799.5 gm.; 100-per-cent, 794.6 gm. Accurate tables showing the proportion of water and alcohol in mixtures have been experimentally made. If in making a varnish 1 kg. of alcohol is used in place of 1 litre, the result will be that the varnish will be too thin.

In the American varnish trade, alcohol is used almost only for dissolving shellac. What is known as denatured alcohol frequently contains 20 per cent of kerosene, and varnish made with it is slow to dry. Wood-alcohol is a more powerful solvent than ethyl (or grain) alcohol, and evaporates readily; the vapor is somewhat poisonous, and it should not be used in a closed room. If it is to be used continuously, as in a paint-shop, extremely good ventilation must be had. It sometimes causes incurable blindness. Little or no danger attends its use out of doors, or where the ventilation is sufficient. All varnishing-shops should be well ventilated. The writer has

seen fainting, with serious injury to health, caused by turpentine-vapor, and intoxication by vapor from grain-alcohol shellac.

Wood Alcohol.—Wood or methyl alcohol, CH_3OH , is obtained in the dry distillation of wood for making acetic acid; the acid is neutralized and the alcohol separated by fractional distillation. It is a colorless, strongly smelling liquid, specific gravity about 0.8, boiling-point 66° , readily inflammable and burns with a non-luminous flame. The commercial article usually contains acetone. It mixes in all proportions with alcohol, spirit of turpentine, and coal-tar naphtha. It dissolves fats, oils, and resins readily, and as a resin solvent is used instead of the more costly grain alcohol in varnishes, which besides are more volatile and dry more quickly; it is especially useful in mixtures with other volatile solvents for dissolving resins.

Ether.—Ethyl ether, $(\text{C}_2\text{H}_5)_2\text{O}$, also called sulphuric ether, is made in a continuous process from ethyl alcohol and sulphuric acid at 140° , alcohol being constantly added. It is freed from alcohol by shaking it with water, and dried by distillation over lime or chloride of calcium.

Ether is a very mobile, very volatile liquid, with an ethereal odor, and is an anæsthetic; its specific gravity at 17.4° is 0.72; boiling-point 34.5° . Its evaporation produces cold. It is very inflammable and its heavy vapor is a source of much danger from fire. Its vapor mixed with air explodes on ignition. It is slightly miscible with water, which dissolves about 10 per cent of ether. Water may be detected in ether by adding carbon bisulphide, which will cause turbidity if water is present. It mixes in all proportions with alcohol. It is a useful solvent and vehicle for extracting many organic substances; easily dissolves

resins. If varnish made with ether dries too quickly, because of its extraordinarily low boiling-point, alcohol is added to correct it.

Acetone.—Acetone, $\text{CH}_3\text{-CO-CH}_3$, is obtained in the dry distillation of acetate of lime. When pure it is colorless, with a characteristic ethereal and cooling odor, specific gravity 0.814, and boiling-point 56° . It mixes in all proportions with alcohol, ether, and other solvents. It is used either alone or mixed with alcohol, as a solvent for resins, such as shellac, sandarac, etc., and for pyroxyline and celluloid. Acetone lacquer may be made, for example, by dissolving shellac (to which may be added guaiac resin) in technically pure acetone, and reducing the solution with some spirit of turpentine and alcohol to dissolve the coloring-matter.

Carbon Bisulphide.—Carbon bisulphide, CS_2 , is made by conducting sulphur vapor over incandescent carbon. It is a colorless, poisonous, highly inflammable, very mobile liquid, with a peculiar, offensive odor; its vapor produces unconsciousness. Its specific gravity is 1.27, being, therefore, heavier than water. It may be kept under water, on account of its being very volatile. Its boiling-point is 43° . It takes fire very readily and burns with a blue flame to CO_2 and SO_2 . If kept under water it may be separated by putting both in a funnel provided with a stopcock; the carbon bisulphide will be at the bottom and may be drawn off pure. It dissolves not only many organic compounds, such as resins, fats, caoutchouc, etc., but also inorganic substances, as phosphorus, sulphur, etc.; the last-named solution is used in vulcanizing india-rubber. Impure CS_2 , such, for example, as contains uncombined sulphur, is not suitable for making varnish; if such were used the

resulting varnish would dry with but little lustre. As has already been said, a mixture of 100 parts carbon bisulphide and 6 or 8 parts absolute alcohol will dissolve caoutchouc and on evaporation leave it unchanged. Carbon bisulphide is also a solvent for gutta-percha. A mixture of equal parts of carbon bisulphide, spirit of turpentine, and benzole is used as a solvent for powdered copal which has not been melted or subjected to distillation. Only white Angola, Congo, and Manila are largely soluble in this solvent.

Chlorhydrine, Carbon Tetrachloride, and Terpeneol.

—The new resin solvents, α -dichlorhydrine, epichlorhydrine, carbon tetrachloride, and terpeneol have already been mentioned as solvents for copals. Dichlorhydrine, $C_2H_5Cl_2HO$, boils at $176^\circ C$. and is scarcely inflammable; epichlorhydrine, C_2H_5OCl , boils at $117^\circ C$: Dichlorhydrine is soluble in alcohol, spirit of turpentine, and benzole; carbon tetrachloride, CCl_4 , is not inflammable nor explosive, and is practically incombustible; it dissolves, cold, a series of hard and soft resins, as Siamese benzoin, dammar, elemi, mastic; heated, its solvent powers are greatly increased. All the varieties of shellac are only slightly soluble in it; but a mixture of 70 parts by weight of this liquid with 30 parts of alcohol will, when warm, dissolve 25 per cent. Sandarac is but slightly soluble in it, but 9 parts of it mixed with 1 part alcohol dissolves this resin easily. The use of this liquid either alone or with alcohol as a solvent has already been described under the subject of copals. Terpeneol dissolves medium-hard and soft copals (Manila, Kauri, and Brazilian) completely, and some West-African varieties, as Angola and Sierra Leone, in great part. The problem of making oleoresinous varnishes from copals

and similar resins without melting them has been made the subject of patents by A. Tixier in Billancourt and L. Rambaud in Paris. As described, a resin, Kauri for example, is dissolved either in pure terpeneol or in a mixture of it with an equal weight of spirit of turpentine, then in small quantities linoleic acid is gradually added, and finally boiled linseed-oil. The operation is carried out in an autoclave, in which the mixture of the ingredients may be completed. The high price of terpeneol is an objection to its use.

4. COLORING-MATTERS

The aniline colors are especially suitable for varnishes. In certain colors, as green and violet, no others are available. The following are rarely used: turmeric, from which alcohol easily dissolves a bright yellow coloring-matter; annatto, a yellow-red, disagreeably smelling dyestuff, from the seeds of a tree (*Bixa orellana*); aloes, the dried and purified sap of an African tree, soluble, with a yellow color, in alcohol; dye-woods—campeachy, barwood, red sandalwood,—and saffron, the dark-yellow, dried stigmas of the saffron-plant, *Crocus sativa*. An investigation by Harry Smith on the action of light on colored brass lacquers has shown that the vegetable colors, turmeric, sandalwood, saffron, dragon's-blood, and annatto, fade completely in sunlight; that turmeric, saffron, and annatto cause the brass to blacken in the light; that certain coal-tar colors, as metanil-yellow auramin and primulin, since they do not blacken the brass, are better colors for lacquers than turmeric, saffron, and annatto; that dragon's-blood is better for copper-colored lacquers than sandalwood because it does not fade so rapidly or completely; that gamboge is more suitable for making yellow and gold lacquers than

metanil-yellow, auramin, primulin, turmeric, saffron, and annatto, because it fades very little and does not blacken the metal.

It appears from this investigation that the prejudice which some hold against the use of aniline colors in varnish is not justified, especially regarding colors ranging from citron-yellow to deep wine-red.

As suitable coal-tar colors for varnish the following (from Meister Lucius & Brüning, Höchst a. M.) are recommended, among others: Auramine (conc., O), Chrysoidine (A, C, cryst.), Vesuvin (O, 2 R), Victoria yellow (O, double, conc.), Janus yellow (G, R), for yellow colors; Cachou brown (D, G), Dark brown (M, MB), Janus brown (R, B), for browns; Fuchsine (R, B), and Janus red (B), for red; Methyl violet for violet; Malachite green (cryst., extra), Brilliant green (cryst., extra), Janus green (G, B) for green; Methylene blue (Ia D), Janus blue (G, B, R), for blue; Coal black (O, I, II), Janus black (O, I, II), Nigrosine (R, O, D) for black. Besides these the following are used in varnish-making: indigo-carmine as a blue color; Prussian blue, in leather varnishes; white zinc, white lead, chrome-yellow, red lead, ultramarine, vine-black, lamp-black, various ochres and other pigments which cannot now be enumerated.

Mention has already been made of the use of colored resins; and the coloring of varnishes will be again discussed.

5. CHEMICAL PRODUCTS

In making lacquers and varnishes various compounds of manganese, lead, and zinc are used, to quicken the drying of drying-oils. Before discussing in detail the action of dryers on oil it may be said that it is a process of catalysis. The

oxidation of linseed-oil, according to Fokin, is reduced by the presence of catalyzers from four or five days to two or three hours. Recently, according to S. A. Fokin (*Jour. der russ. phys.-chem. Ges.*, 1907, p. 307), it has been shown that fifteen metals have compounds which act in this way, the list being as follows, arranged according to their activity:

1. Cobalt, manganese, chromium, nickel (iron, platinum, palladium);
2. Lead, calcium, barium;
3. Bismuth, mercury, uranium, copper, zinc.

The oxygen in the higher metallic oxides is effective, and the more so the higher the degree of oxidation of the oxide. Coincident with the atomic auto-oxidation there may be a molecular one, especially if but little of the catalyzer is present, or if its action is weak. The process of oxidation of oils and oil-acids may be followed by observing oil or varnish spread in thin layers on glass plates. The thickness of the film, within certain limits, makes no difference; that is, the amount of oxygen absorbed is proportional to the thickness. The rapidity of the reaction varies in proportion to the cube root of the concentration of the catalyzer. The absorption of oxygen is, from $\frac{1}{5}$ to 20 atmospheres, proportional to the pressure. By raising the temperature the rapidity of action is greatly increased, as a rule.

The following lead compounds are used: litharge or lead protoxide: PbO ; red lead or peroxide (orthoplumbate), Pb_2PbO_4 or Pb_3O_4 ; sugar of lead or acetate of lead, $\text{Pb}(\text{C}_2\text{H}_3\text{O}_2)_2 + 3\text{H}_2\text{O}$; resinate of lead, and linoleate of lead. The manganese compounds are the sesquioxide, Mn_2O_3 ; hydroxide, $\text{Mn}_2(\text{OH})_6$; peroxide, binoxide, or black oxide, MnO_2 ; borate of manganese, resinate, and linoleate of manganese. Finally, there is a resinate of zinc, and a

double resinate of lead and manganese. The resinates of lead, manganese, and lead-and-manganese are each prepared in two ways, one by melting and the other by precipitation.

The drier should be used only when pulverized as fine as possible. Red lead, or minium, is especially subject to adulteration with barytes; manganese borate is cheapened with oxide of zinc. Manganese peroxide gives off oxygen ($3\text{MnO}_2 = \text{Mn}_3\text{O}_4 + 2\text{O}$) by high and protracted heating. On this account in making the so-called manganese varnish, a mixture is sometimes used of peroxide and sulphuric acid with the hot linseed-oil, which gives off oxygen as indicated in the following reaction: $\text{MnO}_2 + \text{H}_2\text{SO}_4 = \text{MnSO}_4 + \text{H}_2\text{O} + \text{O}$. The manganese compounds (excepting the peroxide) are used in amounts of about 1 to $1\frac{1}{2}$ per cent; lead compounds in larger quantity, because lead is less effective than manganese. The manganese preparations have proved on the whole better than the lead compounds; in particular manganese borate yields a varnish of such excellent qualities that it must, in general, be preferred as a drying agent over all other preparations. It is best made from iron-free manganese sulphate (MnSO_4) and borax ($\text{Na}_2\text{B}_4\text{O}_7$). To do this, 1 part of manganese sulphate is dissolved in 10 parts of distilled water, and a little of this solution is added to some soda solution to see if it contains iron; if it does the precipitate will be greenish or yellowish, but if pure it will be white. If pure, this manganese solution is added to hot borax solution as long as a precipitate is formed; this precipitate is washed with hot water and dried.

According to Hoyer, a useful drier may be made in the following manner; manganese sulphate is dissolved in

water, and pulverized slaked lime is added to this solution, with agitation, until the solution becomes dark in color. The mixture now contains hydrated peroxide of manganese and calcium sulphate. It is obvious that if an excess of lime is present the fatty acids in the linseed-oil with which it is used will be saturated. By the use of this siccative, after it is dried and powdered, linseed-oil is cleared and its fatty acids are neutralized (by the formation of lime-soap). It produces a clear drying-oil, which with hard resins makes durable, lustrous, and elastic varnishes. Siccative extract (fluid siccative) is a solution of resinates or linoleates of manganese in spirit of turpentine, or red lead and lead acetate cooked in linseed-oil, etc. For example, a liquid drier may be made by melting 10 parts of manganese resinates in an enamelled kettle, then add 12 parts spirit of turpentine and cool; 3 per cent of this drier will dry linseed-oil quite hard in twenty-four hours. A liquid drier which can be used with cold linseed-oil is made by heating 5 parts of resinates of manganese with 10 parts of linseed-oil until they unite, then thin with 7 parts spirit of turpentine. A lead drier may be made by boiling 2 parts sugar of lead and 2 parts red lead with 7 parts linseed-oil; when sufficiently cooked thin with spirit of turpentine.

Zinc compounds, as the oxide, sulphate, or resinates, are used as driers. Zinc oxide is especially used in combination with manganese borate, and zinc sulphate with litharge, with good results. Resinate of zinc is best in the precipitated condition; it dissolves quite easily in spirit of turpentine or linseed-oil. It is chiefly used mixed with other driers. Its effect as a drier is not inconsiderable. It influences the color of oil but very little.

The drying effect of linoleate of manganese is consider-

ably less than that of the resinates of manganese. The latter is a better drier than resinates of lead; manganese varnish forms a harder and more durable coating than lead varnish. Resinates of manganese and lead used together have a more intensive action than either of them used alone. In using the combined resinates there is often a black sediment formed, which consists largely of sulphide of lead. This indicates sulphur in the oil, which should therefore be tested for sulphur; and if any is found the oil should be used with manganese resinates only. Varnish containing lead compounds may take hydrogen sulphide from the air, which may be present in small amount in the air of inhabited rooms, etc., in consequence of which compounds of lead and sulphur may be formed which will cause it to become dark in color. There are also some pigments, as vermilion, cadmium yellow, etc., which are sulphur compounds. If the lead-varnish comes in direct contact with one of these, sulphide of lead will shortly be formed which will injure the beauty of the color and the lustre. According to the investigations of Amsel, drying-oil made without boiling with metallic resinates is not only not inferior to boiled oil but for many purposes is to be preferred.

According to the experience of the writer (which now has amounted to about a quarter of a century in the varnish and paint industry), the notion that lead present in varnish as a drier causes it to darken from the action of sulphur is a purely academic conception, without experimental basis. In the first place, sulphur compounds in the air are acid, and oleoresinous varnishes are indifferent to dilute acids, as a rule; the lead is present in minute quantity, and is in chemical combination with the oleoresinous matters, which are insoluble in water, and it is extremely doubtful if even strong H_2S can take the lead out of such combinations; so far as the writer

knows, no chemist has ever claimed to have done so; the writer has tried it in various ways without success. While it is true that moisture sometimes penetrates varnish films, it does this by their porosity, not through the substance of the varnish; and the lead is not in these pores. Lead combined in minute amount in varnish is not like lead hydrate mixed in great volume with oil as a pigment, where it is mechanically exposed to the atmosphere by the gradual perishing of the oil by abrasion or chemical action. The darkening of varnish surfaces is probably due chiefly to the action of light on the surface to which the varnish was applied; it has always been known that light darkens wood, canvas, or almost any material long exposed to its action; and partly to the yellowing of the linseed-oil in the varnish, which cannot be prevented by any known means.

Grinding pigments containing sulphur, as vermilion, cadmium yellow, etc., in grinding japans or oils loaded with lead compounds is, of course, out of the question. Ordinary lead driers hold lead in weak combination; otherwise they would be of no use. It may be that varnishes containing even small amounts of lead, if mixed with sulphides and left indefinitely, will give up the lead in part to the sulphur, and it is not claimed that such varnishes should be used in contact with unstable sulphides; but this is a different thing from ordinary atmospheric action. Articles of furniture, such as chairs and desks, in the lecture-rooms of chemical laboratories, if varnished with thoroughly good oleoresinous varnishes, do not darken more than similar articles in the lecture-rooms of other buildings; but inferior and cheap varnishes are quickly destroyed in such rooms.

CHAPTER IV

MAKING LACQUERS AND VARNISH

I. PREPARATION AND CHOICE OF RAW MATERIALS

IT is necessary that copals and amber should have a suitable treatment before they can be used in making varnish. It has already been said that copals which have been dug from the earth are covered with a more or less thick incrustation of decomposed resin, which must be removed by washing or otherwise.

For washing copals (Zanzibar, Benguela, Angola, Accra, Sierra Leone, etc.) a large wooden tank is necessary, which is half filled with a solution of 5 parts by weight of potash in 100 parts of water. Into this solution the copal is put until it fills the tank to about a hand-breadth from the top. In about six hours the incrustation becomes softened; the contents of the vat are then agitated with a broom of twigs, so that the pieces of resin may rub against each other and the incrustation come off. When this operation has been carried on for about twelve hours, the cleaned copal is taken from the lye and washed with fresh water, until there is no longer an alkaline reaction, and finally it is spread out in thin layers and dried in the air. Deep cavities in the pieces of copal are scraped out with a knife.

Raw amber, copals, and related resins may also be treated in the following manner: the resin is immersed for one minute in red fuming nitric acid, which may be slightly warm. It is next spread out on stone flags, five to ten

minutes, by which time the adhering acid is exhausted, and a layer about 0.5 mm. thick is dissolved from the surface of the resin. The pieces of resin, dried and separated from the incrustation of yellow powder, are then put in a 10-per-cent solution of caustic soda, slightly warm. It is then washed with warm water until the dark brown adherent scum is entirely removed. After this, the resin, which is now pure and clean, is put for one minute in a bath of 1 to 5 per cent sulphuric or acetic acid, then well washed, and dried. Amber, copals, and other resins may be thus purified.

After cleaning as above described the copal is sorted. The large pieces are first picked out, and then it is put on a sieve with openings 1 cm. square. What remains on the sieve is put in a cask, and the rest is put on another sieve with openings $\frac{1}{2}$ cm. square ($\frac{1}{4}$ sq. cm.). The sifted portion goes on the finest sieve, which has twenty-four openings per sq. cm. The large pieces which were first taken out are broken with a hammer for inspection, and separated into sorts according to purity, as are also the smaller pieces which have been sieved. All those portions which contain much impurities are kept by themselves. On account of the fact that their organic impurities char and blacken the whole mass when the resin is melted, this impure material is not fit for making varnish, or at least not for transparent varnish. Each sort of copal must, according to its hardness, be broken into pieces before melting; the normal size for Zanzibar may be taken as .5 cm. sq., for West-African copals .75 cm. sq., for Manila, Kauri, etc., 1.5 cm. sq. The comminution of copals is done by hand-labor with cutting pliers, or in a mill or machine made for the purpose.

Mills for Resin, Shellac, and Copals.—To reduce copals and other resins to small pieces, a suitable mill is made by Aug. Zemsch, at Wiesbaden. It is a machine which consists of a hard steel conical mill, the cones adjustable

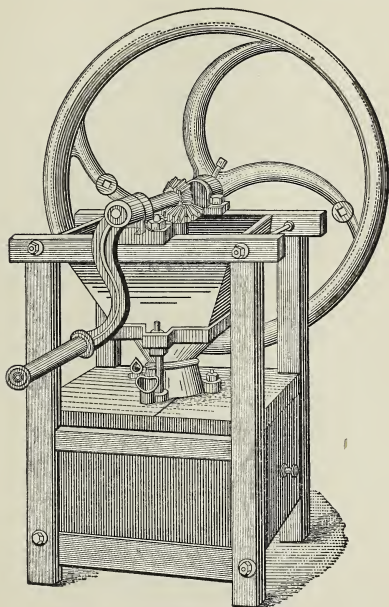

FIG. 1.—Mill for Grinding Resins.

as to distance from each other. By separating them the size of the fragments is increased. It can be so adjusted as to produce fragments of different sizes, and even to reduce the resin to a coarse powder; it will operate on either hard or soft resins.

After breaking up the copal it is sifted; dust and chips are used only in dark varnishes. Hard resins are ordinarily classified in two or three sorts, but the softer ones, as Manila and Borneo, are graded according to their color and purity into four or more grades. Copal which has been reduced to powder by grinding in a mortar easily sticks together; the principal object of pulverizing it is to use it with a solvent either cold or moderately heated, to make a solution; it should for this reason be made as fine as possible. To prevent it from caking and to promote solution it is coarsely powdered, then mixed with sand or powdered glass; it may then be more finely pulverized. This has already been mentioned.

Under the subject of shellac information has already been given as to the methods employed in its solution, and also its bleaching.

Asphaltum is broken up with a hammer, in a suitable box, into pieces as large as a nut; the dust and chips are used with the rest.

Dammar has the dust and smallest fragments sifted out, and the remainder is sorted according to its light or darker color into two grades. Mastic and sandarac have the dust removed, and these are spread out on white paper and sorted according to clearness.

The preparation of linseed-oil, including its bleaching, has been described under linseed-oil. The like is true of spirit of turpentine, of which only the best rectified sort is used for making fine varnishes. While turpentine substitutes have recently come into use, and in some cases are good equivalents in whole or in part, their use is to be discouraged because they unfavorably influence the drying of varnish.

2. GENERAL REMARKS ON MELTING AND DISSOLVING RESINS

It may be said that those pieces of resin which resemble each other in lustre, color, transparency, etc., are, as a rule, alike as to solubility. For this purpose the resins should be prepared as has been directed, and also should be classified and arranged according to their distinguishing characteristics, especially their color and clearness. For fine, water-clear varnish only the best and clearest pieces can be used; the more deeply colored pieces are to be used for more ordinary varnish.

Sifting is practised with the copals, dammar, mastic, and sandarac. All resins, as hard copal, etc., which must be melted before dissolving in linseed-oil or turpentine, must be in uniform pieces. The manner in which copal or amber is melted and combined with drying-oil and then with turpentine will be described later. Copal in pulverized condition is not well suited for melting; it is found that if it is melted it will make only dark-colored varnish. On the other hand, if the copal or other resin, as shellac in thick flakes, sandarac, colophony, acaroid resin, etc., is to be dissolved in a solvent or mixture of solvents, it should first be reduced to a fine powder. It is, nevertheless, to be remarked that if the powdered resin is put directly into the solvent the minute particles of resin will cohere and form lumps which are enveloped by a layer of thick half-dissolved resin, which hinders further action of the solvent; to prevent this annoyance the powdered resin may be mixed with an equal volume of an inactive substance before attempting solution. Suitable substances, having no action on the resins, are powdered glass and pure, fine quartz sand. If

some of either of these is mixed with the powdered resin it will not form lumps when wet with the solvent, and its particles are therefore easily dissolved. The glass powder for this purpose is made by grinding glass in a mortar or otherwise; the coarse pieces are sifted out, and then the finer portion is put in a fine sieve of metal cloth, and the fine powder thus obtained will not quickly settle out of the varnish.

Resin solvents are used either cold or warm; in the latter case, solution is more rapid. Most of the liquids used as solvents are more or less volatile, as has been said when describing them in detail. Many, as ether (boiling-point 34.5° C. [94° F.]), carbon bisulphide (boiling-point 43° C. [109° F.]), acetone (boiling-point 56° C. [133° F.]), benzine, etc., are extraordinarily volatile; in consequence of this the use of these solvents involves appreciable loss if they are warmed. Moreover, their vapor, and also that of liquids like turpentine, which have a higher boiling-point, is inflammable and on that account dangerous. Because of this endeavor has been made to construct apparatus in which solutions may be made without loss of volatile solvents and without risk of their taking fire. For doing this on a very small scale a small glass flask (bolt-head) may be used, the opening covered with a wet piece of bladder, in the middle of which is a pin-hole. The flask is heated in a water-bath. It may be better done in a still with a reflux condenser, the still being heated in a water-bath. Resins may also be dissolved by the method of G. A. Buchheister-schen. To make a small amount of resin solution a tin canister is used, within which, about half-way from the bottom, some projections are soldered, on which rests a sheet of perforated metal which has a little handle. On

this perforated diaphragm the resin is placed, and enough alcohol is poured in to fill the can up to just above the sheet of perforated metal. The can is then closed with a tight-fitting cover, and set aside. After more or less time, according to the nature of the resin, say in six to twelve hours, the solution will be accomplished. Various other apparatus will be described later.

Concerning the melting of copal or amber it is to be observed that only well-cleaned vessels should be used, and if possible these should be enamelled. After every melt the melting-kettle must be washed with spirit of turpentine. Mention has been made of the sorting of copal; this must be done to preserve its color and purity. The separate pieces of copal must be as similar as possible. If the quantity of resin to be melted is large, the dust and chips may be put on the top and melted with the rest, if desired; but if the quantity is small, and especially if the dust lies beneath, on the bottom of the kettle, this may not be done. To melt the copal quickly, and to hasten the work, a strong fire is needed; the copal must be made so fluid, in the melting process, that it will run off the stirring-rod like water. Foam in the kettle is not allowable, and it is objectionable to have condensed vapors run back down the sides of the kettle.

After each addition of the drying-oil to the melted resin the compound must be tested as to its perfect union. The oil is gradually added to the melt with vigorous stirring; when the first portion of oil is in, a sample is put on a piece of glass and inspected for limpidity and transparence as well as color. The cooled sample on the glass must show no white opacity, striations, or other cloudiness; it will be clear and transparent if the copal and oil have completely

united. If the mixture is turbid no more oil must yet be added, but after a minute or so another sample is examined. If not now clear, the kettle must be returned to the fire and heated until the contents are properly combined. If the drying-oil is, at the time it is added, at a sufficiently high temperature, no cloudiness will appear and the cooking, as above described, will be unnecessary. It is unavoidable that prolonged cooking darkens the mixture, and this makes it essential to have the fire just right to clear the melt without excessive heat; the copal may be easily scorched in too hot oil. It is possible and desirable to have the copal in such a state that it will instantly unite with the drying-oil.

It is found in practice that notwithstanding the careful selection of the resin and following the process of melting as described, there will be a difference in color in different batches. It is therefore customary to examine each melt, after the oil is combined, for color, and to keep the paler separate from the more deeply colored lots, and finally to store these in different tanks; in this way the same lot of copal yields two varnishes, one paler and the other darker.

When the foregoing tests show that the copal and oil are properly united, the contents of the kettle are poured into a larger kettle or tank which is provided with stirring and cooling apparatus, where it is stirred continuously for two hours, either with a mechanical stirrer or with a broad-bladed hand-stirrer. If the mixture becomes too thick to stir, it must be warmed; if too thick and too cold the turpentine, to be added later, will not mix with it. One result of the prolonged stirring of the oleoresinous mixture is its absorption of oxygen from the air.

To get the copal into such a condition that it will be sol-

uole in the drying-oil it must lose in melting, on the average, 15 per cent of copal-oil. It seems unavoidable, in melting a known weight of copal in a small open kettle, to lose a considerable percentage of its volatile portion in getting it ready to combine with the oil; but if done in a larger way, a kettle with a condenser attached may be used; the process of distillation must be immediately interrupted when the contents are ready for the addition of oil. In order to secure the volatile copal-oil which is contained in the copal a melting-kettle is used which has an easily separable dome and vapor-tube connected with a condenser in which the vapors may be liquefied; obviously, such a distilling apparatus must be quite close and tight.

The volatile copal-oil which is thus obtained is of varying densities and boiling-points, and by fractional distillation may be separated into several constituents, which differ in consistence and color. The offensive odor of the vapor may by this means be in great part obviated. The liquid so prepared is a good solvent for semi-hard and soft copals.

Usually the residue from melting copal is immediately burned; in very large establishments it is sometimes mixed with coarse sawdust and made into little pieces which are to be used as kindlings; on a smaller scale it may be mixed with coal-dust and at once put on the fire.

The spirit of turpentine is usually added to the oleo-resinous mass at the end of the two-hour stirring. More will be said, in discussing the manufacture of oleoresinous varnishes, about this, and of the proper proportion of resin, linseed-oil, and spirit of turpentine.

CHAPTER V

OIL-VARNISH AND OLEORESINOUS VARNISH

I. LINSEED-OIL VARNISH

As has been already said, linseed-oil has the property of drying when spread in thin layers and exposed to the air. This quality becomes more pronounced when the oil has been heated for a considerable time. When heated, it first gives off watery vapor; at 100°C. (212°F.) the steam escapes in bubbles. At about 150°C. (300°F.) the yellow coloring-matter of the oil is decomposed by the heat, and by heating further the oil becomes pale in color. If fresh, slimy, and turbid oil is heated to about 80°C. (175°F.) it foams strongly over the whole surface; in this case the heat must be raised slowly until the water and foam are expelled. Usually, and especially with oil which has been held in storage, the heat may be steadily increased until at 170°C. to 175°C. (340° – 345°F.). The foam disappears and the mucilaginous matter is separated from the oil and partly destroyed. If the foam does not disappear on heating the oil to 170°C. (340°F.) it is held at this temperature until it is gone.

Varying with the intensity of the heat and the age and purity of the oil, it takes from two and a half to four hours to prepare clear oil, free from foam. The most rapid method of preparing oil-varnish is by the addition of certain chemical products, chiefly manganese and lead compounds, which have already been described, while the oil is being heated.

At about 170° C. (340° F.), the drying-compounds, which have been ground with oil, are added gradually, in small quantities, to the clear and pale linseed-oil. As the oil foams strongly with each addition of driers, it is necessary to carry on this operation very carefully. When the driers are all dissolved, the varnish is ready to be left to settle. The best product is obtained if the oil along the side of the kettle, or over a part of the surface of the oil itself, shows a thin film.

With lead compounds a varnish (lead-varnish) may be made by the following process:

A suitable quantity (*e.g.*, 100 kg. [30 gal.]) of linseed-oil is put in a varnish-kettle and heated until it begins to foam. The foam is removed with a skimmer, made like a sieve so that the oil which is taken up with the foam may drain back into the kettle. When it ceases to foam and the smooth surface of the oil begins to appear, some well-dried and finely ground litharge, 2 or 3 kg. (4½ to 7 lbs.), is gradually added, and the temperature raised until the oil simmers and gives off vapor. Every eight or ten minutes it should be stirred to prevent the litharge from settling, and this is continued two and a half to three hours. When it has become so thick that threads of oil will string out from the stirring-rod when it is taken out, the fire is increased until thick, heavy vapors begin to be given off. Tested with a feather, when it is so hot that the web of the feather quickly shrivels, the fire is hot enough, and the smoking oil must be rapidly stirred so that it may be heated equally and will not boil over and take fire. Gradually the vapor will diminish; it need then no longer be stirred and the fire may be allowed to go out. The finished varnish, from which most of the residue of undissolved

litharge has settled out, is left quietly in the covered kettle until quite cool. It is then dipped out with a ladle and poured through a not too thick linen cloth, which will remove the greater part of the suspended matter which causes turbidity in the varnish. Thereafter it is stored in casks, not entirely filled, to clarify; the bung-holes of the casks are closed only with paper spread loosely over them to keep the dust out; this increases the drying quality of the varnish.

Instead of litharge, red lead may be used; this is richer in oxygen than litharge, and if in the finest possible state it makes the oil into varnish more quickly and completely than litharge.

One part of litharge, 1 part red lead, and $1\frac{1}{2}$ parts of sugar of lead may be mixed intimately, and 1 kg. (2.2 lbs.) of this mixture put into a bag of thick linen cloth; and this may be suspended in a vessel containing 30 litres (8 gals.) linseed-oil and 30 litres of water, so that it is in the liquid. The mixture is heated until the water is all driven off, and the hot varnish is filtered through a felt filter. In this way a varnish is made without any true cooking of the oil.

As air containing hydrogen sulphide darkens lead-varnish, zinc compounds are sometimes used in place of lead; it is well known that zinc sulphide is white. Varnish can be made by cooking linseed-oil with zinc oxide, but it is rather slow to dry. There is a preparation known in the trade as "zumatic siccativ"; this contains, according to Bolley, 91.84 parts of zinc oxide, 2.12 parts manganese oxide, 2.40 parts quartz sand, boric acid, traces of lead, and an organic substance. The manganese borate plays the chief part, and the other materials, such as zinc oxide, are

added to cheapen it. It is used with colors based on white zinc, to make them dry quickly.

Using manganese compounds good linseed-oil varnish (manganese varnish) may be made, as follows:

Linseed-oil, 100 kg. (220 lbs., say 30 gals.), is heated to 180° C. (360° F.) or 200° C. (390° F.), and then a mixture of 2 kg. ($4\frac{1}{2}$ lbs.) of finely powdered manganese dioxide and 2.5 kg. ($5\frac{3}{4}$ lbs.) of sulphuric acid is added to it. This mixture when heated gives off oxygen ($\text{MnO}_2 + \text{H}_2\text{SO}_4 = \text{MnSO}_4 + \text{H}_2\text{O} + \text{O}$), which oxidizes the oil; at the same time some of the manganese dissolves in the oil. After heating from 1 to $1\frac{1}{2}$ hours some thick milk of lime, made by slaking 1 kg. ($2\frac{1}{4}$ lbs.) of quicklime in water, is added, and after standing twelve hours the varnish is put through a felt filter.

Linseed-oil, 100 kg., is heated to 140° C. (285° F.), 2 per cent manganese oxide in lumps is added, and well stirred for half an hour, until a temperature of 160° C. (320° F.) is reached; it is then allowed to cool, and after standing four days it will be a pale varnish which will not have any further sediment.

In a suitable vessel 10 kg. (22 lbs., say 3 gals.) of linseed-oil is heated, and 2 kg. ($4\frac{1}{2}$ lbs.) of finely powdered, dry, white manganese borate is gradually added with vigorous stirring; it must be thoroughly and uniformly mixed with the oil. It is heated to about 200° C. (390° F.). At the same time 1,000 kg. (300 gals.) of linseed-oil is heated in an oil-kettle until it begins to bubble, and then the aforesaid mixture of oil and borate of manganese is run in, in a thin stream, and the heat raised until the whole is in ebullition. After cooking it twenty minutes it is ladled out and filtered through cotton.

Varnish can be made with resinates in the following manner:

Heat 200 kg. linseed-oil to 140° C. (285° F.), add 4 kg. (*i.e.*, 2 per cent) melted manganese resinate, and stir vigorously half an hour, until the temperature reaches 160° C. (320° F.); then let it cool. After three or four days the varnish is clear and pale.

If precipitated manganese resinate is used, the oil is heated to 150° C. (300° F.); then $1\frac{1}{2}$ to 2 per cent of

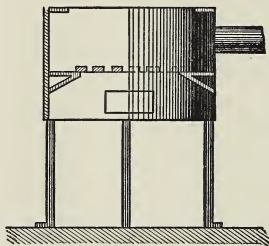

FIG. 2.—Portable Furnace.

the resinate is mixed with a little oil and stirred in the whole quantity of oil and held at the above temperature two or three hours; the varnish thus made will clear by standing.

Linseed-oil varnish has of late been made from the glycerine-free fatty acids of linseed-oil, by heating and adding oxidizing agents. In oxidizing oil the glycerine is destroyed, and so in varnish-making there is a loss of glycerine. For this reason varnish is made, not of the oil itself (linseed or other drying-oils), but of the fatty acids made from it, which prevents the loss of glycerine and also makes oxidation easier and more rapid. The oil is saponi-

fied with caustic soda and this is decomposed by a mineral oil which precipitates the fatty acids, which are washed with water and preserved in wooden tubs.

As the foregoing directions have shown, in making varnish the linseed-oil is sometimes heated only to 170° C. or 175° C., and sometimes to 220° C. or 300° C. Linseed-oil begins to give off bubbles at 100° C. (212° F.); this is solely because some water is present. From 150° to 180°

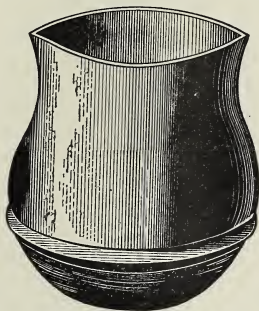

FIG. 3.—Varnish-kettle.

C. the yellow coloring-matter is broken up by the heat; at 180° the oil becomes clear and pale. Oil is changed in its consistence at about 300° , especially if it is cooked at 316° C. (600° F.). In practice varnish is cooked at temperatures ranging from 220° C. (430° F.) to 300° C. (570° F.). For making varnishes which dry well the oil must be held for a period of three hours at 235° to 245° C. (455° F. to 475° F.). The temperature is known by thermometers in metallic cases.

On a small scale oil may be boiled in an iron kettle holding say 50 kg. (15 gals.), with a portable furnace (Fig. 2).

The kettle may be two-thirds full of oil; the fire is started and when it begins to boil the driers are added little by little. When these are all taken up and no more oxygen is evolved, the kettle may be filled and heated further. When the varnish is done the kettle is taken from the fire and the

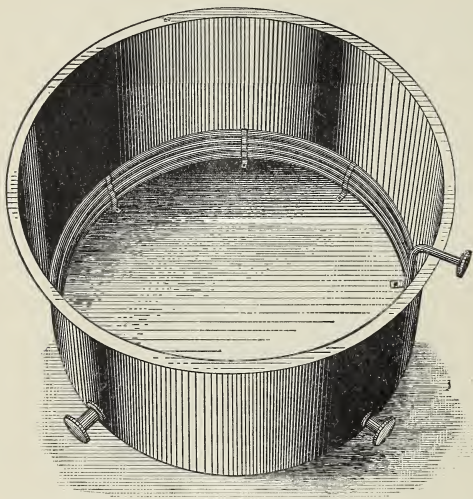

FIG. 4.—Oil-kettle.

contents put in a suitable iron vessel, in which it gradually clears itself. As has already been said, it may also be cleared in storage-tanks. Kettles of various shapes are used for boiling oil. Aug. Zemsch of Wiesbaden makes three sorts, the one shown in Fig. 3, one shaped like a flask, and one cylindrical; these are of enamelled cast-iron.

W. C. Heraeus of Hanau makes oil-kettles as shown in Fig. 4, iron outside, aluminum-lined, with an aluminum heating-coil.

The advantage of using aluminum is that its action to

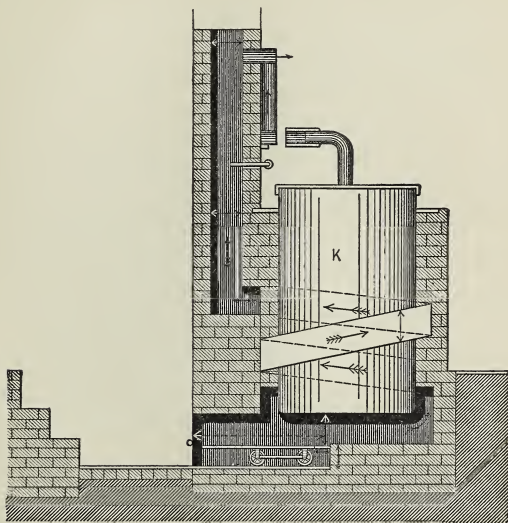

FIG. 5.—Set-kettle for Varnish. The grate is on wheels, by which the fire may be withdrawn.

oxidizing agents and solvents is such that it does not discolor the varnish.

Enamelled iron kettles are satisfactory; but it is to be observed concerning copper, that copper compounds are of a green color, which undesirable peculiarity makes it necessary to have the copper tinned for some uses.

If steam is used as a means of heating the oil, the kettle may be provided with a steam-coil within, or it may be made with a steam-jacket, in which it is usual to carry steam with a pressure of say 60 lbs. per square inch. It is desirable to have these kettles enamelled. Since it is impossible

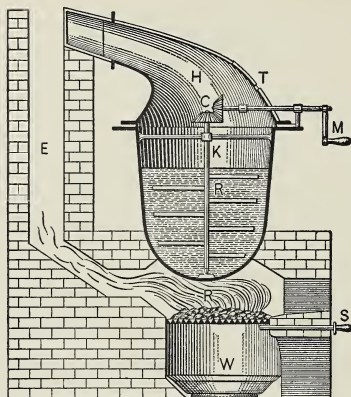

FIG. 6.—Varnish-kettle, According to E. Andrès. The fire, *R*, may be dumped into the water, *W*, by pulling out the support, *S*.

in these kettles to get the temperature of the oil higher than that of the steam (about 132° C. = 267° F.), it is not necessary to take precautions against the oil boiling over, such as have been described. The absorption of driers goes on but slowly, and begins about thirty or forty minutes after steam is turned on; about six hours' cooking is necessary to finish the varnish, after which the oil is drawn off through a pipe which drains the inner kettle, and is stored in a suitable cask or tank. Steam-cooked oil is

paler than that made over an open fire, because made at a lower temperature. The plant may consist of two or more kettles set in an iron frame; when not in use the kettles are stored bottom up. Instead of ordinary steam, superheated steam is also used. A suitable superheater is shown in Fig. 7. In this apparatus the steam is brought from a steam boiler in wrought-iron pipes, several connecting lines of which pass through a furnace, as shown in the illustration;

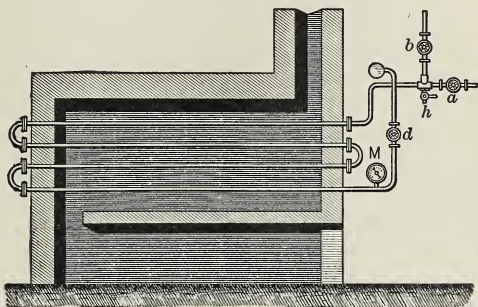

FIG. 7.—Steam Superheater.

these are connected with return bends, outside the furnace. Steam enters by the pipe *d* and leaves by either *a* or *b*. The drip-cock *h* is for measuring the temperature, and the gauge *M* shows the pressure of the entering steam.

Lehmann constructs an oil-boiling apparatus, safe from fire and which removes offensive vapors, shown in Fig. 8, in which the superheated steam coil is placed directly in the oil-kettle; the steam is heated to about 400° C. (750° F.) and the oil is heated by the coil, gradually and uniformly. The oil-boiling kettle has a cover, hung by chains which

pass over pulleys, in which there is a small opening which may be closed; this is for watching the boiling process, introducing driers, and stirring the oil when necessary. Through the cover hangs a thermometer, which dips into the oil, and shows its temperature. The cover terminates above in a sheet-metal pipe, which carries off the vapors

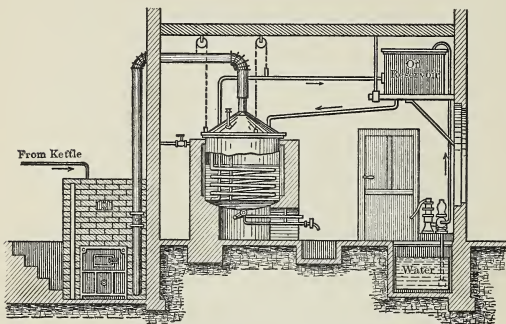

FIG. 8.—Lehmann's Apparatus.

of the oil and leads them to the superheater, where they are passed through the burning fuel and are consumed. To prevent the flame from flashing back through this pipe, it is provided, in the ash-pit of the superheater, with a disk of fine wire cloth, which acts as a safety-gauze. To guard against loss, the kettle has an overflow pipe, through which, without loss or damage, the oil may run into a suitable receptacle and cool. To utilize more fully the heat of the steam, which is still very hot when it leaves the oil-kettle, it is led to an oil-heater, which is placed at a higher level than the kettle, in which the next charge of oil is heated.

Instead of steam, superheated air may be used. This is

blown by a centrifugal fan into the system of pipes of the superheating furnace, and after the air has given up most of its available heat to the oil, it is led back to the fan, so that the same air is circulated continuously between the fan, the superheater, and the varnish-kettle.

Recently air ozonized by electricity has been used in varnish-making. When ozonized air is blown through slightly heated linseed-oil, the oil is rapidly thickened and in a short time is made into a quick-drying varnish. The operation is best conducted in a tall cylindrical vessel, in which an air-pipe terminating in a rose dips to the bottom, and which also contains a steam coil for heating the oil; this is heated to 40° or 50° C. (100° to 120° F.). In the factory is a steam-engine which drives a dynamo, generating a large amount of electricity, and an air-pump which forces the air through the ozonizing-apparatus and then through the oil. As it can escape only in small bubbles from the rose on the end of the air-pipe, and passes through a considerable column of oil, the ozone is all absorbed, and that which finally escapes is only ordinary air. Oil treated in this way is almost colorless, and no drier is needed.

2. COPAL, AMBER, AND OTHER OLEORESINOUS VARNISHES

The oleoresinous varnishes should be made of the hardest resins, such as Zanzibar, amber, Madagascar, red Angola, etc. Besides the resinous ingredients they contain linseed or other drying-oil, spirit of turpentine, and driers. As has already been said, the copals and amber must have been melted before they will dissolve in the drying-oil; the method of melting and of combining the oil has been described. Properly melted copal dissolves without difficulty

in hot oil. It may be remarked that the harder the resin the more difficult it is to melt, and the higher must be the heat both in melting and in combining the oil.

It has been said that the mixture of melted resin and oil must be stirred together two hours before adding the turpentine; it remains to be said how the latter and the driers are to be added. While the copal mixture is very hot only a little spirit of turpentine may be added at a time, and the stirring must not be violent, otherwise too much of the turpentine will evaporate. Concurrently with the turpentine the liquid drier may be added to the oleoresinous mixture. The finished varnish is strained through a cloth and put in storage as hot as may be practicable. The temperature of the storage-rooms (tank-rooms) should not fall below 15° C. (60° F.) and in winter must be heated. In order that the odor of the copal-oil and of the turpentine may pass off quickly, and also that some further oxidation may take place, the varnish tanks are left uncovered about four weeks. A sample is taken from the tank, cooled, and examined as to its consistence (body); it naturally becomes thicker with age; but if it is too thin (which should never occur) it must be thickened by the addition of some varnish made of the same resin and oil, but thinned with some of the thin varnish instead of turpentine; and if it is too thick or heavy, it may be thinned by adding a suitable quantity of spirit of turpentine. It is not uncommon to add the driers to the oil-and-resin mixture while stirring it, before the turpentine is put in; in this case it is cooked in for two hours, until the foam on the surface disappears. The varnish in the kettle is tested as to its quality; a spatula is dipped in it and when taken out is covered with a thick layer which runs

off in clear yellow drops, until the liquid on the spatula gradually becomes a thin film. Letting the drops fall on a glass plate they should not flatten out, and when cold should be of the consistence of a thick, stringy syrup. If the varnish is like this, it is taken from the fire and cooled until the spirit of turpentine can be added in small portions. After each addition of turpentine, when it has been stirred in, a sample is taken and tested for viscosity; if it quickly thickens on cooling more turpentine is added; the end is reached when it is observed that a little more turpentine makes it quickly much thinner. When of the proper consistence, varnish is much influenced by the addition of a little turpentine. As has been already said, various chemical products are used as driers, of which the most important is litharge, then manganese borate and resinates of these metals.

The varnish, when ready for use, must be thickly fluid and have a clear yellow color; when spread on a surface it must flow out evenly, without ridges or brush-marks. After standing six to twelve hours it must be quite dry on the surface, and must subsequently dry throughout so as to form a film which is lustrous and shining in appearance and at the same time sufficiently elastic; it must not crack nor peel off. Exposed to the weather it must remain unacted on for a long time.

There are a great number of formulas for making copal-varnishes. In these the most uncertain quantity is the turpentine; there are differences in the character of the copals, in the consistence of the drying-oil or of the oil-and-resin mixture, and in the temperature at which the turpentine is added, which involves more or less waste of turpentine, that require various amounts of

this ingredient to produce the right degree of consistence or viscosity.

The work cannot be conducted by any established formula, and the directions which have been given in the section on melting of resins are only general in their nature, and vary with different copals or amber.

Bjerregard has proposed to mix the copal (*e.g.*, kauri) with raw linseed-oil and heat the whole in a kettle until the resin is melted. With kauri the necessary temperature is 177° C. (383° F.). When the resin becomes soft or melted, the whole must be well stirred to mix the ingredients well and let any gas that has been formed escape.

After this the temperature must be raised, stirring being continued, and cooking continued until the oil and resin are properly combined, as shown by tests already described. With kauri, a sample taken out will show the desired quality at about 315° C. (600° F.). When this is accomplished the varnish is cooled and thinned, with several hours' stirring, with spirit of turpentine or whatever solvent may be chosen, to which a little drier has been added.

Bjerregard maintains the opinion that by using raw linseed-oil the copal will become thoroughly combined with it by the time the oil comes to boiling. If a more viscous varnish is desired, the cooking is carried on for a longer time. By boiling raw oil at too high a heat more or less of a gelatinous substance is formed, which has a harmful effect on the varnish; for this reason the use of unboiled oil in the manner described is to be preferred. By Bjerregard's method the copal, either ground or in pieces, is added to the hot oil, little by little, and dissolved as has been described. As it tends to rise to the top of the oil during cooking, the apparatus must be so constructed that this may

be prevented. The time of cooking depends on the amount of surface of the apparatus exposed to the source of heat and on the character of the fire. In essentials the making of amber varnish is like making copal varnish; for example, melted amber is heated with boiled oil (or oil-varnish) in a kettle until the amber entirely dissolves, and then the temperature is raised to 200° C. (390° F.), the drier (*e.g.*, manganese borate) is added, the cooking continued an hour, and then it is taken from the fire; when it has cooled to 60° or 70° C. (140° or 150° F.) the spirit of turpentine is added.

Varnish is made by Wilson Neil by melting selected clear pieces of amber (2 parts), adding to it hot, boiled oil, 9 parts, heating the mixture until it makes a thread, and thinning with $13\frac{1}{2}$ parts of spirit of turpentine.

The following method for copal and amber oleoresinous varnishes has been patented by Henri Terrisse (German patent 165008, v. 30, VI., 1904). Hard and medium copals (Zanzibar, Madagascar, Benguela, Angola, Congo, Manila, etc.) may be used. The resin is first dissolved under pressure ($4\frac{1}{2}$ atmospheres) in naphthaline, at a temperature of 250° to 290° C. (480° to 550° F.) in a digester or autoclave provided with a mechanical stirrer; then linseed-oil is added; the whole filtered, if necessary, and the naphthaline is then recovered by distillation in a vacuum distilling-apparatus. The solution thus obtained may be made into a varnish by adding boiled oil, turpentine, and driers. Amber and Accra copal can be used in this way only when mixed with some other copal; *e.g.*, Accra may be used with Benguela. Except Accra, the copals may be dissolved in this way and the loss of weight in melting is avoided. Accra copal dissolves in naphthaline only at a temperature of

345° C. (653° F.) and under 18 atmospheres' pressure, and the solution thus obtained is not suitable for varnish-making; but if Accra and Manila are mixed in equal parts they dissolve together in naphthaline at 255° C. (510° F.) and 4½ atmospheres' pressure. The advantages of this process are the pale color, durability, and lustre of the varnishes so made.

Inasmuch as certain oil-acids, especially the acids of linseed- and castor-oils, have in a marked degree the capacity of dissolving kauri resin, a process has been devised for making a linoleic-acid varnish; the linseed-oil is saponified with caustic soda and the linoleic acid precipitated by a mineral acid, washed, and stored in wooden receptacles; then two parts of powdered kauri resin and one part of linoleic acid are heated to 110° to 125° C. (230° to 260° F.), and a reaction takes place, the copal evolving a volatile aromatic oil and becoming dissolved. This reaction ceases gradually and after four to six hours' heating the solution may be made into a varnish by adding hot turpentine and linseed-oil.

To make, for example, a floor-varnish, 100 kg. of powdered kauri resin and 50 kg. of linseed-oil acids are put in an enamelled iron, steam-jacketed kettle, which is provided with a mechanical stirrer, heated by steam to 125° C. (260° F.) and held at this heat four to six hours. From a kettle which stands at higher level a hot mixture of 350 kg. spirit of turpentine and 75 kg. of linseed-oil varnish (preferably prepared with borate of manganese) is gradually added, and, with constant stirring, 100 kg. rosin spirit and 50 kg. benzine. It is then heated with occasional stirring for an hour, and drawn off into a tank to settle. When clear it is ready for use. In this way kauri may be dissolved

in linseed-oil and turpentine without melting, and made into a varnish.

It may in general be observed, that melted copal treated with hot linseed-oil or boiled oil will not separate; if it separates and settles to the bottom as a solid, hard mass, it is evidence that it was never properly melted. For this reason the greatest care is taken in melting it. But as the melted resin is always darker in color—especially is this true of amber—attempts are constantly made to prepare varnishes, by using various solvents, without melting the resin. On the whole these attempts have not been very successful; varnishes made in this way lack elasticity, unless linseed-oil is added to them; and, when this is done, in most cases all or part of the copal separates. Spirit of turpentine is added to the oleoresinous mixture to give the necessary flowing quality.

If melted copal be dissolved in spirit of turpentine or other volatile solvent, we have a copal spirit varnish. Spirit varnishes form hard films, but they are easily rubbed off. Linseed-oil dries to an elastic film, but it has a dull, mat surface, and has a considerable resistance to the action of the atmosphere. Because of this, linseed-oil is boiled with driers to a varnish; films of this have little hardness and last only a limited time. To give the film hardness, and especially lustre, melted copal is added; by this combining, the latter gains elasticity, and loses its own natural brittleness. To increase the rapidity of hardening the varnish made of copal, drying-oil, and turpentine, driers are added. To remove from the finished varnish mechanical impurities, which are not separated completely by straining through cloth, specially constructed filter-presses are used, which will be described later. After filtering, the varnish

is put in storage, and after standing it becomes clear and good.

From the foregoing exposition it is evident that the varnish film depends on linseed-oil for elasticity and on copal for its hardness and lustre. The proportion of resin and oil is variable; it depends on the nature of the copal; a soft copal will carry only a little oil; many copals will separate from a great quantity of linseed-oil. What are called "fat" varnishes are those in which the weight of the oil is greater than that of the melted resin; medium varnishes have about equal parts of these ingredients; and "lean" or "brittle" varnishes have less oil than resin. These latter should be made of the very hard copals, as Zanzibar and amber. By using the best and palest sorts of copals pale varnishes are made, but amber makes dark varnish. Zanzibar copal is, after melting, a very hard resin and unites naturally with half its weight of linseed-oil, making a varnish that is both hard and elastic. For making varnish to stand weathering the linseed-oil must be especially good and properly prepared; it must dry into a very elastic film. The greater part of the oleoresinous varnishes belong to the middle class, in which the oil and resin are in approximately equal proportions; in this group are the furniture-varnishes, cabinet-varnishes, floor-varnishes, and the like. The consistence of varnish depends largely on the weather; thus, in cold winter weather it may be necessary to add more turpentine to secure the necessary fluidity. If the latter has been standing long it is liable to be very acid, and moreover is not infrequently adulterated, and its use lessens the lustre of the varnish; very old turpentine also makes varnish dry more slowly. An addition of old spirit of turpentine which is strongly acid may, by

the action of acetic and formic acids, throw down the driers in the varnish. Other faults, of which we cannot now speak, may result from the addition of turpentine, especially if in large amount. To avoid using extra turpentine, we may add to an interior house-varnish either a mixture of turpentine and heavy boiled oil (varnish), or the latter alone. If the varnish is too fat and of better quality, a small addition will have no marked influence on its character.

In the third group, the "lean" varnishes, the resins exceed the linseed-oil. As they contain but little oil, they dry quickly. They take up oxygen from the air more rapidly than other varnishes; but since these varnishes, which include among others the rubbing varnishes and stair and floor varnishes, contain but little elastic material, they are more brittle and easily wear off; they are not made of sufficiently hard copal. The prices of these varnishes admit the use only of a middle grade of copal, which is not very hard. To help overcome this difficulty amber may be used in making the varnish.

Amber, being a very hard resin, can combine with an adequate amount of linseed-oil. Amber, however, makes only dark-colored varnishes; for this reason a suitable proportion of very pale copal is combined with the amber, and in this way the dark color of the latter is diminished. A suitable formula is this: melted amber 25 parts, melted copal 25, linseed-oil varnish (boiled oil) 50, and spirit of turpentine 100 parts. For a cheaper sort of varnish colophony (rosin) may be substituted for copal, thus: melted amber 25, linseed-oil varnish 50, turpentine 100, and pale rosin 25 parts; this makes an "amber-rosin" varnish. Another formula is, melted amber 84 parts dissolved in

100 parts linseed-oil varnish, to this add 16 parts clear pale rosin; when dissolved, add 100 parts spirit of turpentine containing 5 per cent of driers. Amber is neutral or indifferent to pigments, while copal often precipitates. In some copal there is free acid, which acts chemically on many pigments used with floor-varnishes and the like. This is especially liable to cause trouble when an acid copal varnish is mixed with lead or zinc pigments, causing the mixture to thicken and even to become hard. Amber floor-varnish, on the other hand, may even be mixed with red lead or white zinc without any such effect. These things must be considered in deciding what materials to use in oleo-copal varnishes. A formula for carriage-varnish is 1 part by weight of Zanzibar copal, 1 to $1\frac{1}{2}$ of linseed-oil, and 3 to $3\frac{1}{2}$ of spirit of turpentine. According to English practice (Wilson Neil) two kinds of varnish are prepared and mixed in the proportion of one to two; the first is made by melting 4 parts of Angola copal, adding $12\frac{1}{2}$ parts linseed-oil, boiling until the mass will "spin threads," then $13\frac{1}{2}$ parts spirit of turpentine. Second, melt 1 part Zanzibar, boil with 9 parts oil as before, then thin with $13\frac{1}{2}$ parts turpentine. Two parts of this are mixed with one part of the first. Another similar pair of varnishes: 4 parts Angola, 9 parts oil, $\frac{1}{8}$ part zinc sulphate, $\frac{1}{8}$ part litharge; the other, 4 parts Zanzibar, 9 parts oil, $\frac{1}{8}$ part zinc sulphate, $\frac{1}{8}$ part litharge. After cooking thin with 49 parts turpentine.

E. Andrès proposes for copal varnish: melted copal 100 parts, volatile copal-oil (from distilling copal) 20 parts, spirit of turpentine 300 to 350 parts, linseed-oil 100 parts. For fat varnishes, made by boiling, from West-African resins, the following proportions are given: copal 1, lin-

seed-oil 1.7 to 2, and spirit of turpentine 3 to 3.5 parts; for medium varnishes, copal 1, linseed-oil 1.3 to 1.5, and turpentine 2.3 to 3 parts. The formula for quick-drying varnish is, copal 1, linseed-oil 1 to 1.1, and turpentine 2.7 to 2.8 parts. Using lead and manganese boiled oil (varnish), to make a fat varnish, use copal 1, oil-varnish 0.7 to 0.9, turpentine 2.5 parts; medium, copal 1, oil-varnish 0.5 to 0.6, turpentine 2.4 parts; quick-drying, copal 1, oil-varnish 0.3 to 0.4, turpentine 2.5 parts.

Using Manila and Borneo copals, and making the varnishes by cooking, as usual, fat varnishes are composed of copal 2, linseed-oil 2.25 to 2.50, and turpentine 4 to 4.2 parts; if the resins are soft less oil is used. Medium varnishes, copal 2, linseed-oil 2, turpentine 4 parts; the quantity of oil is the same for Manila and Borneo. Quick-drying, copal 2, linseed-oil 1.5, turpentine 3.5 parts; extra quick-drying, copal 2, linseed-oil 1, turpentine 3.25 parts. Using manganese and lead oil-varnish, the formulas are, for fat varnish, copal 2, oil-varnish 0.7 to 0.75, turpentine 3 parts; medium varnish, copal 2, oil-varnish 0.6, turpentine 2.9 parts; quick-drying varnish, copal 2, oil-varnish 0.4, turpentine 2.5 parts. Using amber as the resin, and cooking the varnish as usual, the fat varnish is composed of amber 2, oil-varnish 1.9, turpentine 3.9 parts; medium varnish, amber 2, oil-varnish 1.5, turpentine 3.7 parts; quick-drying varnish, amber 2, oil-varnish 1.0, turpentine 3.0 parts. Using lead and manganese oil-varnish we have for fat varnish, amber 2, oil-varnish 1.0, turpentine 2.9 parts; medium varnish, amber 2, oil-varnish 0.7, turpentine 2.7 parts; quick-drying varnish, amber 2, oil-varnish 0.4, turpentine 2.5 parts.

Other formulas for amber varnishes are as follows: amber

50, thick oil-varnish 75, manganese borate 1.75, turpentine 120 parts; this is a carriage-varnish. A first-quality furniture-varnish is composed of amber 50, thick oil-varnish 13, manganese borate 1, turpentine 75 parts; a table-top (bar) varnish, amber 50, pale Manila copal 3.5, thick oil-varnish 50, manganese borate 0.75, turpentine 160 to 170 parts; a floor-varnish, amber 50, thick oil-varnish 4.15, manganese borate 1, turpentine 75 parts; a varnish for tinware, amber 50, thick oil-varnish 18, manganese borate 0.75, turpentine 85 parts. Copal may be combined with dammar: 40 parts pale Sierra Leone copal may be melted and dissolved in 5 parts linseed-oil, and at the same time melt 80 parts dammar and dissolve in 5 parts linseed-oil; mix the two solutions, and thin with 100 parts turpentine, or as much as may be necessary to produce the right consistence. An amber varnish for iron is made by dissolving 12 parts of melted amber together with 5.12 parts Syrian or German asphaltum in 10 parts of thick oil-varnish; to this add 1 part litharge and cook one hour with constant stirring; when sufficiently cool, thin with 48 parts of turpentine.

Rosin-varnish is used only for cheap work. Hardened rosin is commonly used; this has lost its sticky character. Rosin can be used with but a small proportion of linseed-oil; if much oil-varnish is used with it, it regains its sticky nature. When pigments are mixed with rosin-varnish, especially lead pigments, the mixture becomes thickened and useless. Rosin ester is made from rosin, and this combined with copal or amber may be cooked into linseed-oil; this is best done in a closed kettle, in an atmosphere of carbonic acid or other indifferent gas, and with the addition of 1 per cent of peroxide of lead or peroxide of barium or an equivalent, at a temperature of 300° C. (570° F.).

Varnishes made of rosin and China wood-oil have already been described.

3. VESSELS, APPARATUS, AND METHODS FOR MELTING COPALS AND OTHER RESINS; METHODS OF REMOVING NOXIOUS VAPORS; APPARATUS FOR MOVING AND TILTING THE VARNISH-KETTLES.

It has already been set forth that enamelled kettles are desirable for melting copal and amber, and that they should be provided with easily detached vapor-discharging covers, also that fully closed distillation apparatus is in use. The melting-kettle may be provided with a vapor-pipe which discharges into a condenser, from which the volatile copal-oil is collected; closed stills are provided with connections for catching the various oils which come over. Oil-varnishes are best made in enamelled iron kettles provided with mechanical stirrers. Hard resins, copal, and amber are melted in two ways; first, in open or loosely covered kettles, in which case the volatile parts which are driven off are lost; second, by distillation in closed apparatus, by which the volatile portions are obtained as a by-product. In the first-named apparatus the melted resin is directly combined with the drying-oil and the turpentine; the same may be done in the still, but with the latter it is also possible to put the resin, from which the copal-oil has been driven off, in a suitable vessel with the drying-oil and the turpentine, and by heating to 100° to 130° C. (212° to 266° F.), convert the whole into varnish. If the resin is melted over the direct fire, it will be found that the organic impurities are carbonized, and the resulting product is dark in color; but if superheated steam is used, a much paler result is obtained.

Apparatus for melting resin is of great variety as to form and mounting. They are made of copper, copper and iron, cast-iron, and aluminium. As has been already said, when oil is boiled in copper kettles verdigris is formed, which dissolves, and gives a green color to the varnish. Also, copal-

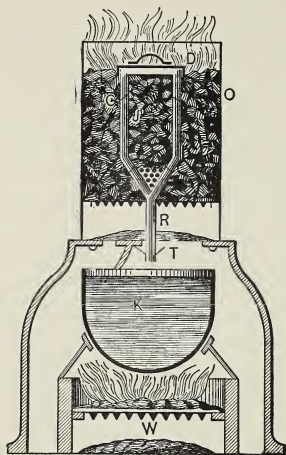

FIG. 9.—Andrès' Apparatus.

oil attacks copper; cast-iron kettles are comparatively free from attack, but their great weight is objectionable. Enamelled iron kettles are desirable; but the enamel should be very durable. It is not desirable to melt resin in too large batches. Portable furnaces of various patterns may be used, and on a larger scale furnaces are built in place for the purpose. In iron furnaces charcoal is used; in others, coal, coke, and gas. When charcoal is used there is no soot or smoke.

For working on a small scale, E. Andrès has designed the apparatus shown in Fig. 9, by which the resin may be melted and the varnish cooked in one operation. *C* is a tightly-riveted cylinder of sheet-iron, which has a cone-shaped bottom, and is supported by several supports in the middle of a blast-furnace *O*, which is heated with char-

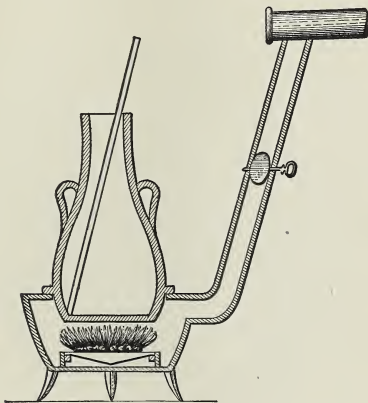

FIG. 10.—Tripier-Deveaux's Apparatus.

coal. This cylinder has a cover *D*, which during the operation of melting is luted on with clay. The cone-shaped bottom terminates in a tube *R*, which passes through the bottom of the furnace and the ash-pit, and to intercept the ashes which may sift through has a conical collar *T*. Within the cylinder *C* stands another, *J*, made of sheet-copper, with a conical bottom, the point of which is perforated with many small orifices, like the rose of a watering-pot. Little strips of sheet metal, which are riveted to *J*, support it

centrally within *C*, from which it is separated 1 or $1\frac{1}{2}$ cm. Under the tube *R*, a kettle is placed, containing linseed-oil, which is kept in slight ebullition by the fire in the furnace *W*. The cylinder *J* is filled with pieces of copal, the cover luted on, and the burning charcoal melts the resin. As soon as the melting copal begins to drop into the oil in *K*, the latter is brought to a brisk boil and constantly stirred.

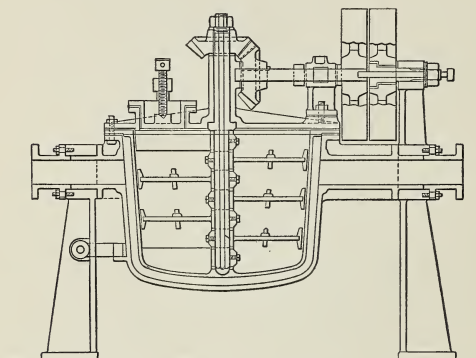

FIG. 11a.—Zemsch's Steam-jacketed Melting and Cooking Kettle.

The melted resin dissolves readily in the varnish made in this way, which is of good quality, but dark-colored. The copper cylinder is not to be cleaned after the operation; the thin layer of melted resin which adheres to it is of advantage next time. In this apparatus 80 to 100 litres (20–25 gals.) of varnish may be made at a time.

A portable furnace has also been made by Tripier-Deveaux (Fig. 10). The melting is done in a copper flask, so made that the bottom is one piece, and the flange, where

it is joined to the upper part, overlaps the opening in the furnace 4 cm., and forms a support for the flask, and keeps the flame from going up its sides. The flask should not be too deep, or it will be difficult to clean. Twenty-five to 30 litres (5 to 8 gals.) is a convenient size. There should be

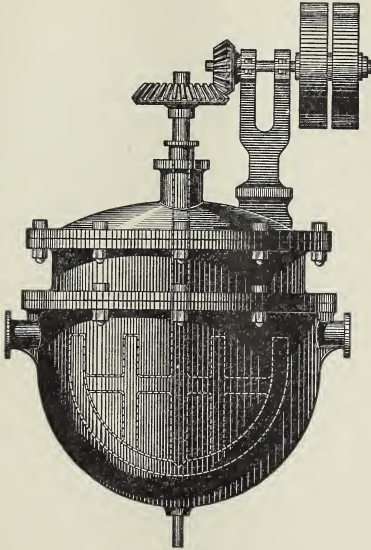

FIG. 11*b*.—Zemsch's Varnish-kettle.

two of these flasks. One advantage in this furnace is that the current of air from the draught-hole and the grate is so arranged as to bring the air into the ash-pit, and the carbonic acid is not mixed with it but passes off.

A steam cooking and melting apparatus, in which copal

may be melted, has been constructed by Aug. Zemsch; it is shown in Figs. 11*a* and 11*b*; it is provided with a mechanical stirrer, and the inner cast-iron kettle is coated with acid-proof enamel. The apparatus rests on supports and may be tilted.

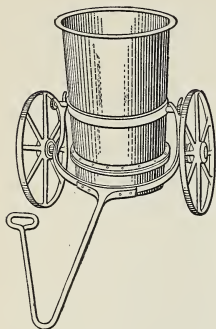

FIG. 12.—Heraeus' Varnish-kettle and Truck.

and with a wrought-iron carrying-ring which has pins to engage in the supporting-fork of the truck; Fig. 14 is a kettle with copper bottom and middle sections, with aluminium lining, and with an aluminium cover and vapor-pipe. The handles on the sides, which also support it when on the truck, are of iron.

Andrès advises that when copal varnish is to be made on a large scale, the resin should be subjected to dry distillation in closed vessels; the most suitable temperature is

Copal may also be melted in the aluminium apparatus of W. C. Heraeus; the advantage of using this metal has already been explained. In Fig. 12 is shown a melting-kettle without the cover, with an iron truck; Fig. 13 shows the kettle with separable bottom and thermometer-tube,

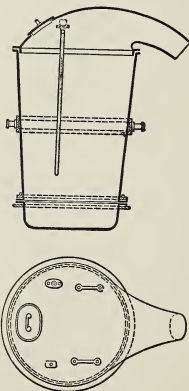

FIG. 13.—Heraeus' Varnish-kettle.

from 340° to 360° C. (650° to 680° F.). At a lower temperature distillation proceeds slowly; at a higher, the resin becomes dark in color. It requires great skill in firing to hold the temperature in the kettle at this point without considerable variation.

Andrès recommends the apparatus shown in Fig. 15 for

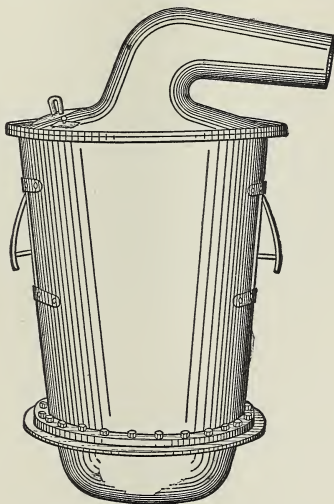

FIG. 14.—Heraeus' Varnish-kettle.

melting copal. It consists of a cylindrical copper still *B*, set in the brickwork *H*, heated over a direct fire, and provided with an outlet tube *A*, which must be encased in fire-clay. In the top of the still there is an opening *O*, closed with a screw-cap, for introducing the resin. A stirrer operated by bevel-gearing from the shaft *G*, serves to agitate

the contents of the retort, from which the pipe *D* conveys the vapors which are given off, to a tin coil in the vessel *K*, which is cooled by water from *W*. The condensed volatile oil escapes at *C*, under which is set a vessel to receive it. Andrès also suggests the use of a sand-bath or a lead-bath to keep the temperature of the retort at the right point,

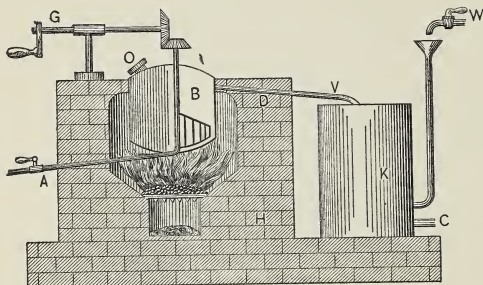

FIG. 15.—Andrès' Gum-melting Furnace.

which is 340° to 360° C. (650° – 680° F.). Lead melts at 334° C. (633° F.); it is melted, and the fire regulated so that the condensed vapor comes off in drops which closely follow one another. As soon as the right amount of copal-oil has been distilled off the distillation is stopped and the liquefied copal is drawn off through the tube *A*, which may discharge it into a drying-oil or a volatile solvent, or else run it into a pan to cool, after which it may at any time be used as desired.

Lehmann has designed an apparatus which is safe from fire and does not allow offensive vapors to escape; it is shown in Fig. 16. It has a copper retort, the lower part of which, where the melting occurs, is encased in an iron

steam-jacket and heated with highly superheated steam; the temperature is determined by a pyrometer. The upper part of the apparatus consists of a removable cover, which can be fastened down air-tight. In this are two capped openings through which the contents may be stirred, the melting process observed, and proof-samples taken. From

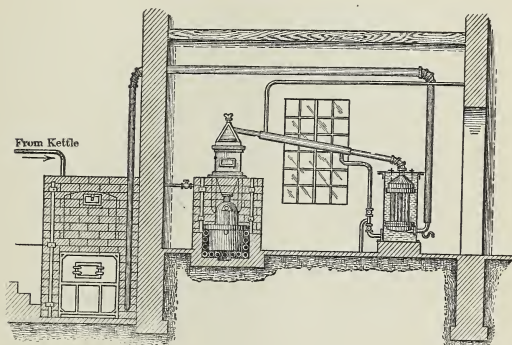

FIG. 16.—Lehmann's Superheated Steam Varnish Apparatus.

the top a pipe, which is in part a Liebig's condenser, conveys the vapor to a condenser, in which the copal-oil is condensed and from which it may be drawn off, while the gases which do not condense are taken off by a pipe and burned in the steam-superheater. Under the retort is the mixing-tank, which is heated by the exhaust steam to 120° to 150° C. (250° to 300° F.), and which contains the prepared linseed-oil necessary for the solution of the melted resin. When fully melted the resin is run down into this oil, which has already been heated, and is combined with it. The spirit of turpentine is not added until the oleo-

resinous mixture has been taken to another room and partially cooled. As soon as the retort is empty, a new charge of copal is run in, and another portion of prepared oil is put in a second mixing-tank, so that the melting goes on almost continually. From time to time the retort is

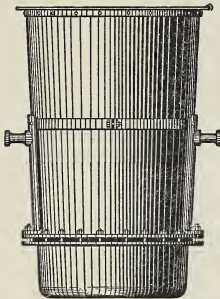

FIG. 17.—Sommer's Varnish-kettle.

boiled out with soda-lye and washed clean. Lehmann's superheated steam oil-boiling plant has already been described. Since in varnish-making the preparation of the oil-varnish and the melting of copal follow, one the other, so a single steam-superheater may be used for both and the steam used first for one and then the other, and the exhaust steam may all be used in a preliminary heating of the oil.

H. C. Sommer is the designer of the so-called German melting-kettle, shown in Fig. 17. It consists of a body to which a bottom is bolted on, so that the bottom, which has the most wear, can be replaced without renewing the body of the kettle. The kettle is provided with trunnions, by which it may be connected to the varnish-truck; the latter is better suited for picking up and setting the kettle than for drawing it about. The body of the kettle is of sheet-iron, enamelled or merely polished, and the bottom is cast-iron, enamelled. The pipe for carrying off the vapor is of galvanized iron. The arrangement of a modern melting-plant ("chimney") is shown in Fig. 19. There are three general methods for disposing of the

obnoxious vapors generated in this work: the first consists in passing them into a tall chimney, so that they may be carried away and so diluted with a large amount of air as to be less objectionable; the second is to destroy them in a specially constructed furnace, but this is expensive and there are, moreover, some risks of explosions, besides which the gases are not all combustible; the most success-

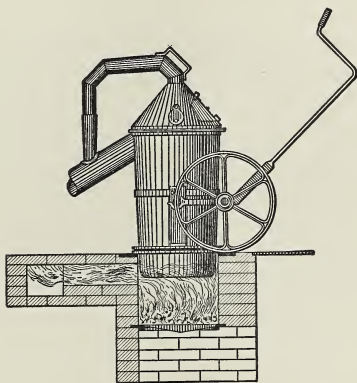

FIG. 18.—Sommer's Kettle, Truck, and Fire.

ful way is to cool the vapors and condense them as much as possible or absorb them, so as to destroy their objectionable qualities. This is effected with water, either pure or a solution of some kind. The common objection to this method is that the apparatus requires considerable space, and where mechanical exhaust is employed the cost is somewhat high.

H. C. Sommer has constructed, without exhaust, a

condensing and absorbing apparatus, which occupies but little room and is efficient; it is shown in Fig. 20; in this the spray of the jets of water used in cooling produces enough draught.

The apparatus for condensing the vapor consists of a set of small chambers or receptacles, or a system of suction-pipes so constructed that the vapor is drawn through a closed system of piping, in which patented jets are placed

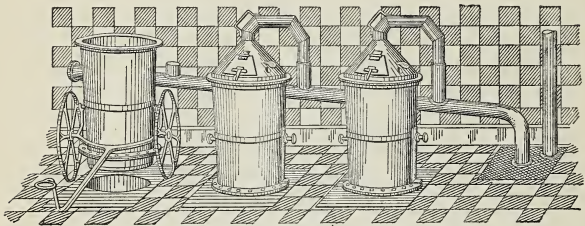

FIG. 19.—German "Varnish-chimney."

for spraying water or other liquid under pressure, which is projected into the enclosed space in cone-shaped jets of fine spray. In this way the gas is thoroughly intermingled with the liquid, so that it is entrained and condensed, or is dissolved by a solvent or absorbed. The extent of the condensing-system and the numbers of jets depend on the readiness with which the gas is absorbed; the jets are so arranged that the vapor which escapes one passes on to another, being impelled by the force of the escaping spray. The water is drawn off, and may be used over again, using for this purpose a pump which draws off the water or solvent and forces it again through the jets. After condensing or absorbing these ill-smelling

vapors, they must be neutralized or otherwise treated to make them suitable for further use.

Of undoubted value for every varnish factory is an apparatus for raising and tilting the varnish-kettle, which is made by T. George Weber, in Dresden. Kettles provided with trunnions, both large and small, may by this be raised to any height not exceeding $1\frac{1}{4}$ metres (4 feet). Not only can it be used for this, but it is quite suitable for

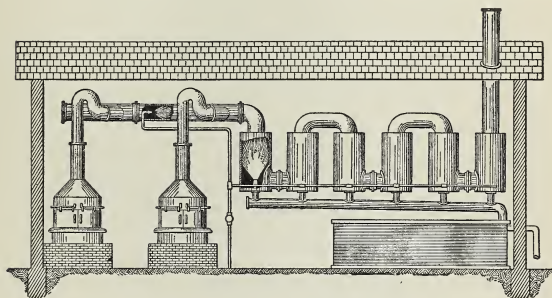

FIG. 20.—Condenser.

loading or unloading heavy weights, such as casks, baskets, etc., on or off wagons.

The construction of this machine can be easily understood from Figs. 21, 22, and 23. Its chief merit is that by its aid the varnish may be poured off in a slow, quiet, secure manner, which can be regulated so as to flow by drops, and the residue is retained in the kettle, giving a clearer varnish than would otherwise be obtained. The operation of the machine is as follows: The kettle is placed on the platform, the adjustable arms are attached by their terminal hooks to the trunnions of the kettle, and by turn-

ing the winch the kettle is raised to a height corresponding to that of the cask or tank into which it is to be emptied. During this part of the operation the hook-carrying arms shorten by their parts sliding on each other; but now the

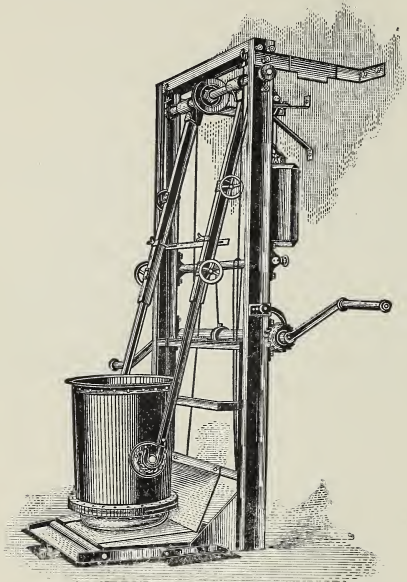

FIG. 21.—Weber's Elevator, First Position.

four little hand-wheels are turned, which clamp the arms and make them stiff; and next, the bolt which locks the tilting platform is loosed, allowing the platform, which carries the kettle, to tilt. By further turning the winch

the upper part of the kettle inclines outward slowly and steadily, and the varnish which it contains is poured off gradually and gently without disturbing the sediment. The kettle can also be emptied almost instantaneously by

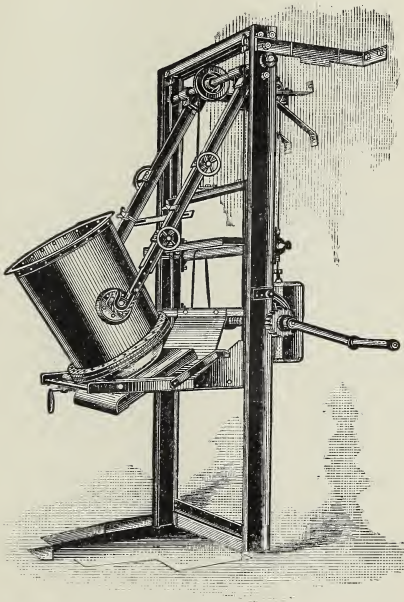

FIG. 22.—Weber's Elevator, Intermediate Position.

turning the crank; the kettle, because of the cylinders in the platform, slides until it reaches the rim in front, which, as soon as the kettle begins to be inverted, acts as a stop and prevents it from slipping downward. A cogwheel with a

catch enables the operator to let go of the winch and hold the kettle at any desired height and inclination. When the kettle is emptied, by loosening the catch and reversing the winch, it comes back to its former position, and rests

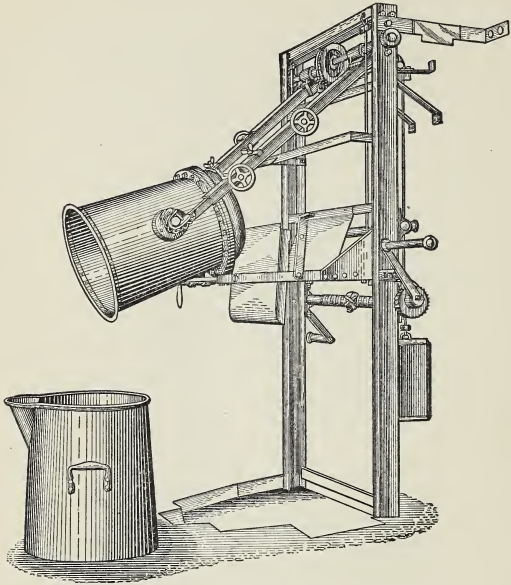

FIG. 23.—Weber's Elevator, Final Position.

easily on the pivoted platform. By locking it with the bolt which was loosened before, the platform is made fast; then the hand wheels are loosened, and when the winch is now turned the arms draw out and the platform with the kettle is lowered. The safety-pins which hold the hooks

can now be withdrawn, and the kettle stands free, ready for removal.

By suitable adjustment of the arms, kettles of various sizes may be attached to the hooks. The platform slides on four interior rollers, which lessen the friction. Two wire ropes, passing over pulleys at the top of the machine, enable the height to be regulated at will, and a counter-weight which balances the platform diminishes the labor.

CHAPTER VI

TURPENTINE AND BENZINE VARNISHES

I. TURPENTINE VARNISHES

THESE are made by dissolving resins in oil of turpentine, without the addition of any fixed drying-oil. Thus, for example, sandarac varnish is made by dissolving sandarac (with additions of mastic, pale rosin, and Venice turpentine) in oil of turpentine; dammar varnish by dissolving dammar (usually with some Venice turpentine) in the same liquid; mastic varnish is a similar solution of mastic, with Venice turpentine, camphor, elemi, etc.; asphaltum varnish is a turpentine solution of Syrian or American asphaltum (or coal-tar pitch) with or without the addition of rosin or melted amber. For making copal-turpentine varnishes, L. E. Andès has found that a solution of alcohol in turpentine is the most suitable solvent for various copals, such as Manila, Borneo, Sierra Leone, and Benguela, which may thus be made into turpentine varnishes.

Dammar varnish, which is esteemed because of its being colorless, is considerably inferior in hardness and durability to copal; the latter has a higher market value than dammar, and a mixture of it in copal varnish must be regarded as an adulteration; but dammar is clearer and more transparent than mastic varnish, which is often used as a picture varnish.

Varnishes made in this way are beautiful coatings. If mixed with other varnishes the films take longer to harden. While turpentine varnishes are slower to dry than alcohol

varnishes, they are, on the other hand, less brittle. In practice they are mixed so as to combine their good qualities; but also spirit varnishes are made of soft copals, to make them less brittle. On account of the high price of turpentine it is often mixed with coal-tar naphtha and benzine, and the solutions of resins thus made are thinned with spirit of turpentine.

As turpentine vapor is injurious to the health, it is necessary in factories where it is used to provide an abundant supply of fresh air to the rooms where it is used by the workmen.

2. BENZINE VARNISHES

Besides turpentine solutions, resins may be dissolved in benzole or coal-tar naphtha, and in benzine or petroleum ether.

Black pitch, soft copals, asphaltum, dammar, mastic, and the like, are in general easily soluble in benzole or other light, volatile coal-tar distillates; asphaltum in particular is easily soluble in these solvents. Benzole is therefore used in making valuable metal lacquers which have asphaltum for a base; also in varnishes like cheap leather lacquer, which contain black pitch dissolved in coal-tar naphtha. Often it seems desirable to use these solvents in such a way as to make a thickly fluid solution of the resinous matter, which may then be thinned with spirit of turpentine, 90-per-cent alcohol, etc., thus appreciably diminishing the time which would otherwise be necessary in making these varnishes.

Benzole varnish, which when applied to smooth surfaces forms films which are quick-drying and lustrous, not inclined to scale off, durable and of good covering quality,

may be made, for example, in this way: In a steam-jacketed kettle, properly fitted up, 50 parts by weight of 90-per-cent benzole is placed, with 20 parts of coarsely powdered colophony (rosin), which dissolves by stirring. To this, with constant agitation, 45 parts of coarsely powdered coal-tar pitch is gradually added, and the temperature raised to 50° or 60° C. (120° to 140° F.). An hour's agitation causes solution; after which, to stop the evaporation of the solvent, cold water is introduced into the steam-jacket, and the solution reduced to the ordinary temperature.

To clarify this solution it is siphoned off into a deep closed tank, from which it may be drawn by a stopcock. The residue which settles out is suitable for making briquettes.

3. ASPHALTUM VARNISH

As has been said in the preceding section, asphaltum varnish may be made by dissolving asphaltum in benzine; spirit of turpentine may also be used in place of benzine.

A lacquer suitable for metals like brass, bronze, etc., is made by dissolving 10 parts of asphaltum in 100 parts of benzine; a black baking varnish for iron articles, forming a lustrous black covering, contains 50 or 60 parts asphaltum to 100 parts benzine. This forms a thin film which will receive a firm polish when rubbed. Petroleum-asphaltums rendered fluid by heat may, by adding spirit of turpentine or benzine with siccativ, be made into varnish of good quality as regards application; the addition of driers is necessary, as without them the coating will remain soft and sticky. Asphalt varnish made with turpentine mixes especially well with linseed-oil boiled to a varnish. It is not unusual to make up an asphaltum varnish with linseed-

oil varnish and afterward thin it with turpentine and benzole. Thus, for example, is made a leather varnish, melting together asphaltum, coal-tar pitch, colophony, wax, and paraffine, and adding linseed-oil varnish and Paris blue (Prussian blue precipitated with alumina); after cooling this is thinned with turpentine and benzole. The leather is first blackened with tannin and vitriol and then a thin layer of this varnish is spread on it.

4. CAOUTCHOUC VARNISH

It is to be observed that caoutchouc-oil is but a little superior to oil of turpentine in regard to its solvent power; and therefore the latter, which is less expensive, is more generally used, as is also benzole. The most approved method is to cut the caoutchouc into small pieces, which are well dried, and then put into carbon bisulphide, which causes them to swell greatly and partially dissolve; the solution is drained off, and benzole is added to the residue in successive portions; the solutions thus obtained are added to the carbon-bisulphide solution.

To make varnish of hardened caoutchouc, it is broken in small pieces and melted, the melted mass poured out on a piece of sheet metal, and when cold broken into fragments. These are dissolved in a mixture of equal parts of rectified oil of turpentine and benzole.

The solution of caoutchouc by itself in benzole or carbon bisulphide dries so quickly that it is difficult to apply it as a uniform film. A varnish made by the process last described, with benzole and turpentine, or one made of a mixture of caoutchouc solution and a copal lacquer, dries somewhat more slowly, and appears to be more practicable. In making these solutions the fact should not be forgotten

that the vapor of carbon bisulphide is dangerous to the health of the workman.

It must, nevertheless, be admitted that the varnish as commonly made by the methods which have been described are unsatisfactory; and this has occasioned the working out of a new process with caoutchouc and colophony. The caoutchouc is first dried in a drying-closet at 70° to 80° C. (160° to 175° F.), until it ceases to lose weight, or nearly so; at the same time some colophony is dried by melting it. The dry raw materials are melted at as low a temperature as is practicable; to the melted mass some white zinc or other inorganic pigment is added, and the mixture is thinned, not with copal lacquer, but with a colophony varnish made by dissolving 50 parts of thoroughly dry colophony in 40 parts of absolute alcohol and 40 parts of benzine. With this a mixture of syrupy consistence is made, which is ground through a paint-mill, to make a uniform product, which is thinned to the desired consistence with more of the rosin varnish.

The varnish prepared by this method is practically water- and acid-proof.

To make a compound varnish of caoutchouc or gutta-percha with Chinese varnish, pure caoutchouc is melted in a steam-jacketed kettle, and when the thickly-fluid mass has partly cooled the crude Chinese varnish is added gradually, in quantity varying from twice to twenty times the amount of the caoutchouc. When thoroughly mixed this makes a varnish, ready for use, giving a film of great elasticity. Instead of pure caoutchouc, gutta-percha may be used for this purpose; also vulcanized caoutchouc or vulcanized gutta-percha, containing $2\frac{1}{2}$ to 10 per cent of sulphur.

CHAPTER VII

ALCOHOLIC AND OTHER VOLATILE AND NON-VOLATILE VARNISHES

I. SPIRIT VARNISH

FOR making ordinary spirit varnish a portable cast-iron enamelled kettle is suitable; it should be set at such a height that it can easily be stirred with a paddle-shaped stirrer about a metre (40 inches) long, with a blade 6 cm. ($2\frac{1}{2}$ inches) broad, and a shaft 3 to 4 cm. ($1\frac{1}{4}$ to $1\frac{3}{4}$ inches) in diameter. The resin is first broken up and put in the kettle, then covered with 95-per-cent denatured alcohol; this should stand 5 to 8 cm. (2 to 3 inches) above the resin. With the stirrer the contents of the kettle are continually turned over, so as to bring the resin from the bottom to the top; by energetic stirring solution will, in most instances, be secured; if the little pieces of resin tend to gather into sticky lumps, these must be rubbed against the wall of the kettle with the stirrer. It is sometimes desirable to mix powdered glass or sand with the powdered resin; this prevents its forming adhesive masses. When the solution is accomplished, if it is desired to make the varnish more elastic by the addition of galipot, elemi, or the like, these substances may be made fluid by heat and added to the solution. The remainder of the solvent may then be added, the whole energetically stirred, and then a cover is placed on the kettle.

After standing about a day the varnish will have settled,

and may then be strained through a fine cloth and filtered, usually through a bag-filter.

Various sorts of apparatus have been constructed for making spirit varnishes; one, a double kettle which may be used with heat, by A. Zemsch, is to be recommended; also one for making varnish with absolute alcohol, by A.

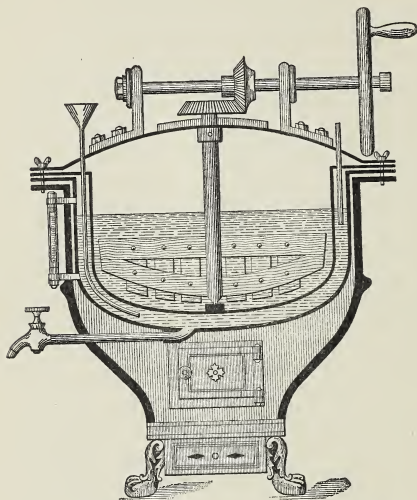

FIG. 24.—Zemsch's Spirit-varnish Apparatus.

Würth. The first-mentioned (Fig. 24) consists of a stove surrounding an ordinary rough cast-iron kettle, within which an enamelled kettle is mounted. The contents of the latter are heated in a water-bath, which prevents the resin from burning on the bottom. A stirring-apparatus causes solution to take place quickly. The necessary outfit in-

cludes a water-gauge, inlet and exhaust steam pipes, and a drain-cock. With a gas-heater the portable stove may be made of sheet metal.

The apparatus of A. Würth (Fig. 25) is distinguished by its provision for bringing the hot vapor of absolute alcohol into contact with the resin and thereby dissolving it. One part of the apparatus consists of a boiler for making the alcoholic vapor, and the other part is arranged

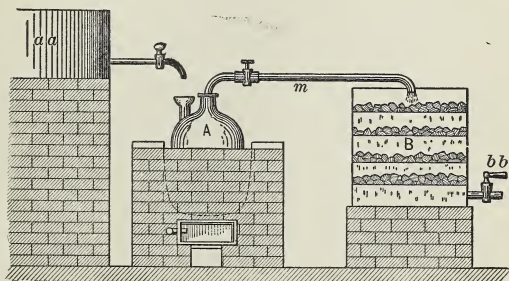

FIG. 25.—Würth's Apparatus.

for the solution of the resin. The copper kettle *A* (or better, an enamelled iron kettle) is fixed in a water-bath and filled from the reservoir *aa*. The cylinder *B* is made of iron plate and enamelled within, contains several perforated shelves to hold the resin, and has an outlet-cock which also provides for circulation of the vapor. The vapor is generated in *A*, passes through the connecting pipe *m* to the cylinder *B*, then through the layers of resin; as it dissolves the latter it condenses and as it passes down from one layer to another the solution becomes stronger, and at last is allowed to run off through the outlet cock *bb*.

This last is connected with a condenser to recover any vapor which would escape, and to cool the solution. For making 300 kg. (75 gals.) of varnish the cylinder should be 1.6 metres (5 ft.) high and 0.8 m. (32 inches) in diameter. The value of a varnish depends on its making a film which combines a certain degree of toughness and elasticity with a fine lustre. The use to which a varnish is to be put must always be considered in making it.

For example, varnish for leather must be flexible and soft; for photographic purposes it must be hard, with a certain elasticity; and metal lacquer must be as hard as possible and usually have a smooth, lustrous surface. A high degree of hardness is always associated with brittleness. The hard resins, such as hard copal, amber, and shellac, make hard and lustrous but also brittle varnishes; spirit varnishes made of these resins lack durability; they soon show cracks and in time fall to powder.

Before beginning to make a varnish it is necessary to select the resins; either such as make a hard and brittle film, or a softer resin, or by the addition of the latter to impart a degree of toughness to such as are too brittle. Especially suitable for giving toughness and flexibility are natural turpentine, galipot, elemi, sandarac, and mastic. In many cases it is customary to add to the concentrated solution of resin some castor-oil or copaiba balsam; for example, to certain varnishes of acaroid resin it is usual to add a soft resin or turpentine, to lessen its tendency to chip or peel off. So also for photographic varnishes, Venice turpentine and castor-oil are added, together with camphor, for the like purpose; and if a finished varnish proves to be too hard and brittle for a given use, it may be softened in the same way; or

if too soft, some hard copal, or shellac, or amber is added to it.

It should, however, be understood that in general it is not to be expected that spirit varnishes will show great durability. The elasticity imparted by soft resins lasts only as long as the ethereal oil which they contain; and when this volatile oil evaporates the film loses the toughness which was in this way imparted to it.

In practice it is usual to keep in stock solutions of resins and make mixtures as required. For example, a solution may contain 1 part of ruby shellac and 2 parts of 90-per-cent alcohol. If not wanted at once it is not necessary to filter it, since by standing a few weeks it will clear itself by settling, and the clear liquid may be drawn off as required.

For ordinary polishing varnish for tables this solution may be thinned with an equal volume of alcohol, thus making a 1:4 solution.

For bookbinder's varnish shellac may be used, either with alcohol and oil of turpentine alone, or in combination with dragon's-blood, gamboge, sandarac, and Venice turpentine, equal parts, dissolved in alcohol.

For gold lacquer it is necessary to have, in particular, solutions of dragon's-blood and of gamboge; if the lacquer is to be of a reddish tint, or warm gold color, it will contain more dragon's-blood, but if it is to be of a clear pale gold color, the proportion of gamboge is increased. In determining the amount of coloring-matter to use, samples may be applied to tin-plate, on which the color will appear as the lacquer dries; by testing in this way, adding one or the other color, the desired tone may be secured.

If various resin solutions have been prepared in the manner described, it is often possible to prepare a desired varnish quickly. Thus, suppose it is desired to make so-called Chinese gold lacquer; a varnish is on hand made by melting together soft copal and shellac, the melted mass cooled and pulverized, then cooked with thickened linseed-oil varnish, and on cooling thinned with oil of turpentine. This may gain the desired gold color by the addition of solutions of dragon's-blood and gamboge in the manner already described.

Shellac spirit varnish (polishing varnish) is made from orange or ruby shellac 10 parts, Venice turpentine 3 parts, alcohol 36 parts; for pale varnish orange shellac is used, for dark, ruby shellac; for white polishing varnish bleached shellac is necessary.

Bookbinder's varnish is made with orange, ruby, and bleached shellac. Ordinary and dark lacquer consists of shellac 10 parts, Venice turpentine 3 to 4, and alcohol 36; for colorless varnish, shellac 11, Venice turpentine 3, and alcohol 40. Instead of Venice turpentine, oil of turpentine may be used; for example, shellac 10 parts, oil of turpentine 1 part, alcohol 30 parts.

For floor varnish, thick turpentine or galipot may be used in place of Venice turpentine; or it may be made of colophony and oil of turpentine.

Leather varnish may be made as follows:

(a) Colophony	30 parts
Turpentine	30 "
Oil of turpentine	30 "
Sandarac	60 "
Shellac	120 "
Alcohol (90 per cent)	900 "

The filtered solution is colored with 15 parts of fine lamp-black which has been mixed with some alcohol. Also to these ingredients 60 parts copal may be added if desired. The black varnish thus made withstands the flexibility of the leather.

(b) Alcohol (90 per cent).....	600 parts
Logwood extract.....	20 "
Bichromate of potash.....	4 "
Indigo carmine.....	3 "
(Natural) turpentine.....	200 "
Shellac.....	40 "

The extract is dissolved in the alcohol and the bichromate, dissolved in water, added to it. In the resulting black solution the turpentine and the shellac are dissolved; finally the indigo carmine is added, which gives the black varnish a blue tint.

For many purposes, *e.g.*, for lacquer for engravings, for transparent metal-lacquer, photographic varnishes, etc., bleached shellac is necessary. The following formulas are in use:

(a) LACQUER FOR ENGRAVINGS

Bleached shellac.....	10 parts
Sandarac.....	10 "
Mastic.....	4 "
Camphor.....	4 "
Alcohol.....	160 "

(b) METAL LACQUER

Bleached shellac.....	10 parts
Sandarac.....	10 "
Mastic.....	5 "
Amber.....	5 "
Alcohol.....	100 "

(c) For photographic varnish the following is suitable:

Bleached shellac.....	5 parts
Mastic.....	1 part
Oil of turpentine.....	1 "
Alcohol.....	30 parts

In making varnish of acaroid resin, the resin, red or yellow, is pulverized, and dissolved in alcohol on a sand-bath or a water-bath. The residue, considerable in amount (especially with red resin), is repeatedly washed with alcohol, and these washings added to the solution. A common formula calls for 10 parts of resin with 11 parts of alcohol, in which a suitable proportion (about 20 per cent) of soft resin, such as rosin or Venice turpentine, is dissolved; this makes a serviceable varnish. The latter ingredients are to prevent the varnish from flaking off; copaiba balsam or castor-oil may be used for the same purpose. If a harder varnish is desired, some shellac is added.

Sandarac and mastic varnishes are made as follows:

ELASTIC VARNISHES:

(a) Sandarac.....	50 parts
Venice turpentine.....	7.5 "
Alcohol.....	150 "
(b) Sandarac.....	20 parts
Mastic.....	10 "
Rosin.....	10 "
Camphor.....	2 "
Alcohol.....	120 "

WHITE VARNISH SUITABLE FOR BOOKBINDERS:

(c) Sandarac.....	6 parts
Mastic.....	3 "
Elemi.....	3 "
Alcohol.....	150 "
(d) Sandarac.....	25 parts
Venice turpentine.....	15 "
Alcohol.....	100 "

FOR USE AS A PAPER VARNISH:

(e) Sandarac.....	50 parts
Thick turpentine.....	30 "
Alcohol.....	150 "

For making spirit copal varnishes only such copals can be used as will readily dissolve to a clear solution, free from slimy or stringy qualities. Manila and Borneo copals are used, the soft Angola and the newer Sierra Leone.

These varnishes may be made by such formulas as the following:

(a) Manila copal	16 parts
Venice turpentine	4 to 5 "
Alcohol (95 per cent)	30 "
(b) Borneo copal	11 parts
Elemi	4 "
Alcohol	27 "
(c) Sierra Leone copal	10 parts
Venice turpentine	3 "
Alcohol	10 "

Rosin varnishes, which can be used on common work, are made from American rosin:

(a) White rosin	22 parts
Venice turpentine	4 "
Alcohol (95 per cent)	15 "
(b) Pale rosin	23 parts
Venice turpentine	4 "
Alcohol	16 "
(c) Dark rosin	22 parts
Thick turpentine	4 "
Alcohol (95 per cent)	14 "
(d) Rosin	22 parts
Thick turpentine	4 "
Oil of turpentine	4 "
Alcohol	12 "

2. VARIOUS NEW VARNISHES, VOLATILE AND NON-VOLATILE

Although the matt (or flat) varnishes have been described several times, *e.g.*, under the subject of monochlorbenzole, it will be in place to give here some further particulars regarding them.

Volatile matt lacquers are usually ether solutions of resins; they may be made by mixing resin solutions with such volatile solvents as will not by themselves dissolve the resins. So, for example, we may make a solution of sandarac in ether, mix it with a fourth its volume of benzole, and thus have a lacquer which will form a film like ground glass. If a solution of dammar in benzole is mixed with ether, it makes a good matt varnish. In making these it is important to know the solubility of resins in various volatile solvents, *e.g.*, oil of turpentine and alcohol or benzole and alcohol; wax and refined asphalt are also of use; likewise mixtures of solutions of acaroid resins with spirit-soluble Manila resin; and mixtures of varnish with finely powdered starch, or with fuller's-earth, gypsum, and other mineral substances.

In making oleoresinous flattening varnish, wax is sometimes added; it may be dissolved, cold, in oil of turpentine to a thick solution, and this may be added gradually to the varnish. Chinese wood-oil is used in making very fine flattening varnishes, which must not be heated so much as to cause the loss of this quality.

A matt varnish may be made as follows:

Bleached shellac.....	100 parts
Glycerine.....	20 "
Galipot.....	20 "
Alcohol.....	200 "
Ether.....	100 "

A photographic ground-glass substitute may be made by dissolving at 40° C. (104 F.) 4 parts of dammar in 30 parts of toluol in a water bath; with this is mixed, by shaking, a solution of sandarac in ether (proportion 10 : 30), and finally add a very little absolute alcohol.

Hugue makes a colorless matt varnish by dissolving 40 parts of sandarac in 500 of ether, and adding 10 parts of Canada balsam.

Chlorhydrin has been used for a considerable time in making lacquers. Dichlorhydrin dissolves kauri and some other copals in the cold, if they are broken into small pieces and well dried. Thus, 1 part of kauri, prepared as just directed, may be mixed with 1 part of dichlorhydrin, allowed to stand for a time, then 1 part of strong alcohol is added, and finally the whole is warmed until complete solution takes place. If now to this 10 to 15 per cent of linoleic acid or castor-oil is added, a varnish is obtained which is paler than the oleoresinous varnish made in the ordinary way. Spread on the natural surface of wood which has not been treated with a filler, it forms a quick-drying film which can be rubbed and polished with linseed-oil.

H. Flemming, who first investigated the solvent powers of chlorhydrin for resins, found that the various nitro-celluloses were easily soluble in dichlorhydrin and especially in epichlorhydrin. They are also serviceable for nitro-cellulose compounds, such as celluloid.

Celluloid, as has already been said, may be made into varnish by dissolving it in alcohol and ether, acetone and amyl acetate. These solvents are very inflammable, and are moreover objectionable from their strong odor. These disadvantages are not found with chlorhydrin; its boiling-point is high enough so that there is little danger of its taking fire, and it has no objectionable odor. Nitrocellulose is extremely soluble in it, forming clear solutions in epichlorhydrin in any proportion desired. A 20-per-cent solution is so thick that it must be thinned to make a varnish.

Chlorhydrin can be used as a substitute for amyl acetate in zapon and dipping lacquers.

Among other volatile lacquers the ethereal solutions of dammar and copal are important. The former is made by dissolving thoroughly dry dammar in ether, with or without the addition of camphor; this is not very durable, but may be mixed with almost any spirit, oil, or ether varnish, and these are suitable for white wood, for paintings, maps, and the like.

There are many ways of making lacquers for bronze powder. Solutions of resins may be made in carbon tetrachloride, or with that and alcohol, which are then freed from acid by treatment with alkali, after which the bronze powder may be mixed with the varnish; another way is to dissolve gutta-percha in benzole and filter it, and add the bronze powder; and Stroschein has patented a process of melting dammar with a carbonate of an alkali for three days and then the product is held for a month at a temperature of 50° C. (120° F.), after which it is dissolved in petroleum ether.

According to Kayser, powdered dammar is mixed with calcined soda and then melted; the cooled mixture is dissolved in benzine.

Stockmeier's method is to dissolve dammar or a similar resin in petroleum benzine and then add $\frac{1}{4}$ its volume of 10-per-cent ammonia-water. After vigorous shaking for a minute it is allowed to stand and settle, when it separates into two parts, the lower layer being an ammonia solution containing the free acids of the resin. The benzine solution is siphoned off, and the operation repeated. In this way an acid-free solution of the resin is obtained. The objection to the use of such a solution as this as a metal lacquer or

for a vehicle for bronze paint is that dammar, according to Andés, does not make a durable varnish. For this reason preference is given to acid-free varnishes made from shellac, sandarac, Manila copal, and other similar resins.

As most solvents for resins are highly inflammable, the more recent practice is to make varnishes with carbon tetrachloride, which is non-inflammable and non-explosive.

Shellac dissolves in a mixture of 70 parts by weight of carbon tetrachloride and 30 parts of 95-per-cent alcohol, to the extent of 25 per cent; sandarac and mastic are soluble in 90 to 80 parts (by weight) of tetrachloride and 10 to 20 parts of alcohol; if more than 95 per cent alcohol is employed, shellac will dissolve more freely, and other insoluble resins, as dammar, dissolve as much as is wished. By varying the proportion of tetrachloride the solvent power of the solution may be varied, and thus, according to L. E. Andés, two sorts of lacquer may be prepared: the one to be brushed on, which has good flowing quality and is transparent; the other a dipping, or pouring, varnish, which, because of the great fluidity of the tetrachloride, does not need to be brushed out, but by dipping forms satisfactory and lustrous films. Andés says that oleoresinous varnishes may be made with tetrachloride of carbon, and those which contain only 10 per cent rapidly become clear and have proper transparency, and flow and work well with the brush; and by adding more, good dipping varnishes may be made in this way.

It has already been said that by the use of terpineol, amber and various resins of the copal group may be dissolved.

A. Tixier and L. Rambaud have patented a process for using terpineol for making lacquers from resins. The

distinguishing feature of this is that terpeneol, or a product made by the action of acids on terpeneol, is used as a solvent for resins along with the more common material, such as oil of turpentine, benzine, alcohol, fixed oils, etc. For example, they make an alcoholic Manila varnish from Manila copal 20 kg., terpeneol 10 kg., alcohol (95 per cent) 20 kg.; also a turpentine Manila varnish with Manila resin 20 kg., terpeneol 9 kg., and oil of turpentine 25 kg.

If copal is digested with terpeneol ether at the ordinary temperature or warmed, after a time it becomes soluble in its own weight of alcohol. The insoluble residue is dissolved in the alcohol. A kauri and oil-varnish may be made thus:

Kauri.....	17	kilogrammes
Terpeneol.....	18	"
Linoleic acid.....	9	"
Boiled linseed-oil.....	11	"
Oil of turpentine.....	33	"

The copal is first dissolved either in pure terpeneol or in equal parts of it and turpentine. Then the linoleic acid is added gradually, and then while the boiled oil is being added the mixture is vigorously and constantly stirred, in order that none of the resin may be precipitated. After this the rest of the turpentine is put in. If refractory resins are to be employed, they must be finely powdered and the temperature of solution will be from 250° to 300° C. (480° to 570° F.). This requires the use of an autoclave, and the later additions of the other ingredients must be effected in this apparatus; after thinning with oil of turpentine the contents may be taken out.

CHAPTER VIII

THE COLORING, BLEACHING, AND FILTERING OF LACQUERS AND VARNISHES

I. COLORS

THE coloring of spirit varnishes is usually accomplished by the addition, to the prepared varnish, of a definite amount of a colored solution. The latter, which, as a rule, is a solution in alcohol, benzole, etc., must be quite clear and concentrated. As with many coloring-matters it is necessary to add a considerable quantity to obtain the desired depth of color; care is necessary to have the varnish of thick consistence, or it may be made too thin by the color solution.

Aniline colors and azo-dyes may be had in all tones and shades, soluble in alcohol and suitable for the purpose, and these may be prepared in such a concentrated form that they do not thin the varnish to an objectionable extent. Black leather-varnish is colored with aniline black, or with logwood extract and bichromate of potash. For cheaper varnish black pitch is used. Gold lacquer for leather is made with a concentrated solution of diamond-fuchsine in alcohol, of which enough is added, to a solution of 2 parts of bleached shellac in 3 parts of strong alcohol, to give it a deep red color. This will form a film on the surface of the leather which, when dry, has a golden color and lustre. The best quality of lampblack is also used as a black color for leather varnish. It must be of a fine, pure black color and readily mix with alcohol and fixed oils.

Black varnishes for metals are usually made with asphaltum; the addition of black coloring matters is not necessary, although lampblack or vine-black is sometimes mixed with them. Ozokerite also makes an adherent and black film on iron; and by cooking 10 parts of oil of turpentine with 1 part of sulphur a lacquer is obtained which on bright metal appears dark brown, but after baking is of a deep black and lustrous. For making so-called gold lacquers, dragon's blood and gamboge are used, as has already been described. Picric acid is also used; to a solution of bleached shellac in strong alcohol, enough picric acid solution is added to make a gold-yellow film. In this lacquer about 1 per cent of crystallized boric acid is dissolved.

For yellow, red, and brown lacquers for wood various grades of shellac-varnish are used, colored with suitable dyes.

2. BLEACHING VARNISH

For many technical purposes it is desirable to have colorless varnishes and lacquers. Although the palest and clearest resins are used in making varnishes, the products are of a more or less strongly yellow color. To remove this, the varnish should before filtering be for a long time digested with freshly burned bone-black, at a gentle heat. As used for such purposes, bone-black is in grains, opaque, deep black in color, and its bleaching effect is due to very finely divided carbon which it contains. For this purpose 10 kg. of bone-black is mixed with 7 kg. of commercial hydrochloric acid in a capacious vessel, and is frequently stirred, for one day, after which it is thrown into a vat with 100 litres of water. When it has settled the water is drawn off and fresh water added; this is repeated until the water

will no longer redden blue litmus paper; the purified bone-black is then dried with heat.

3. FILTERING VARNISH

When resins are dissolved there is always some residue of vegetable organic matter, sand, parts of insects, etc., and these impurities are partly fine and partly coarse, and frequently a part floats on the surface of the solution. If the resin has been melted before dissolving, the heat chars some of the ingredients, so that particles of charcoal are found in the varnish. To purify it, so that it will make a smooth and brilliant film, the varnish is strained through a cloth. Although only the very fine solid particles can go through the meshes of the cloth, which should be finely woven on this account, yet cloth, whether made of metal wire or linen, retains only a part of these impurities.

Alcohol- and turpentine-varnishes are filtered through a loose plug of cotton-wool in the bottom of a glass or sheet-metal funnel, or through a bag-filter. The practice has recently been adopted of using filter-presses for this purpose.

When using a funnel for this purpose it should be covered with a glass plate or other suitable cover, to prevent the evaporation of the solvent. Cotton-wool arrests all floating particles, and it is more rapid than paper; after using the liquid absorbed by the cotton may be expelled by gentle pressure.

The filtering device shown in Fig. 26 is very good. The flask *F*, of glass or sheet-metal, is closed with a doubly-perforated stopper, which fits air-tight. In one of the holes of the stopper the glass funnel *T* is inserted, and in the other a piece of glass tubing *r*,

bent at a right angle. The funnel has a wooden cover *D*, fitting the funnel with an india-rubber ring, which closes it air-tight. In the middle of the cover *D* is inserted a right-angled glass tube *e*, which is connected with *r*, by the rubber tube *k*.

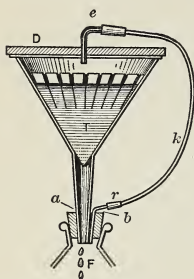

FIG. 26.—Varnish Filter.

In the lower part of the cone of the funnel is placed some cotton-wool, which is pressed gently down into the funnel-tube. The funnel is then filled with the varnish and the cover put on. As the liquid runs through into *F*, the air in the latter is forced out through the passage *r k e*, and into the upper part of *T*; in this way the escape of vapor is prevented, which would otherwise entail a loss of the solvent.

When the cotton of which the filter is composed becomes clogged no more varnish is added, and when what is in the funnel has run out the cover is removed, the cotton pressed to get the liquid out, then removed and some fresh cotton put in.

In the apparatus constructed by E. Andrès (Fig. 27), bleaching and filtering may be simultaneously carried on. The varnish which is to be bleached and filtered is stored in the bottle *A*, which has a side tubulature near the bottom *B*, in which is a tube with a stopcock *C*, which can be connected by a short rubber tube with the tube *D*, which passes through the cover of the vessel *E*. This is a cylindrical sheet-metal receptacle, with a ring *F* near the bottom, which supports the interior cylinder *G*, filled with granular bone-black and having a wire-cloth bottom. The conical bottom of *E* terminates in a tube, which passes through the cover

H, which is fitted with a rubber ring on the top of the funnel *J*, which in turn enters the receiver *K*, and this is connected by the rubber tube *L* to the top of *A*. The apparatus operates substantially like the simpler one first described; when necessary the bone-black can be easily removed; and the process goes on without loss by evaporation.

Varnish may also be filtered with the so-called Dutch apparatus, which uses the principle

of a bag-filter. It consists of a receiver, in the bottom of which are nipples to which the filter-bags are tied; these hang in a vertical cylinder

which is provided with an outlet cock. The liquid is put in the receiver, trickles through the filter-bags, and runs out of the outlet, a clear fluid. The more nipples there are the more efficient is the apparatus; but rapidity of filtration also depends on the character of the liquid and of the filters.

The operator can close the receiver at any time, and this automatically stops the operation, as, when no air

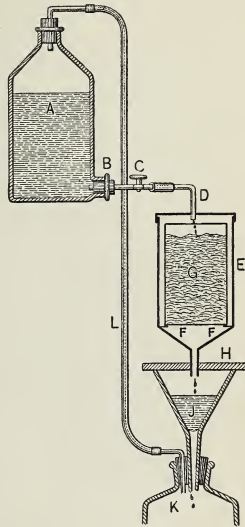

FIG. 27.—Andrès' Filtering Apparatus.

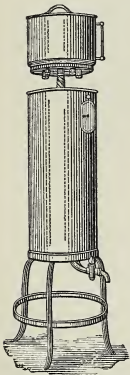

FIG. 28.—Dutch Bag-filter.

can get in, no liquid can get out. For use on a large scale the receiver is hermetically sealed and connected by a pipe with an elevated tank; then it is necessary only to take care of the filtered product. The apparatus is also suitable for oil-varnishes, but for these it must be steam- or hot-water-jacketed, that the varnish may be made more fluid by heat. Oil-varnishes can be filtered only when

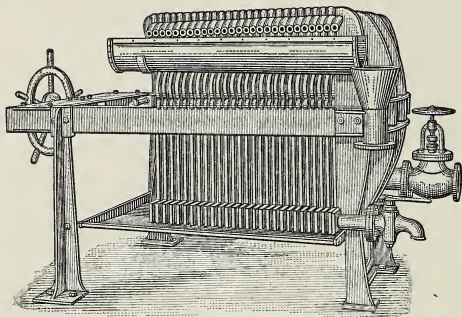

FIG. 29.—Filter-press.

warm, or under a high pressure; for the latter a filter-press is necessary, and is in fact the most common apparatus.

On a small scale a small iron filter-press may be operated by a hand pump, to ten atmospheres (150 pounds per sq. in.). On a large scale the low-pressure filter-press made according to Beeg's patent (by H. C. Sommer, Düsseldorf) is effective. With this the varnish-tank must be from 2 to 6 metres (7 to 20 ft.) above the press. After starting it requires no attendance; the operation is continuous. However, in all filtering through cloth, no matter how closely it may be woven, the varnish is a little cloudy at

first, until the cloth has acquired a layer of sediment, after which it is clear; the earlier portion of the filtrate is put back in the tank of unfiltered varnish. When the sediment accumulates to such an extent as to stop the filter, the press is taken apart and clean cloths are put in. Instead of the varnish running out into an open trough, the Beeg filter may be had with a closed outlet pipe, which avoids evaporation and the action of the air on the varnish.

CHAPTER IX

MANUFACTURE OF PRINTERS'-INK, LITHO- GRAPHIC-VARNISH, SOAP, RESIN AND CASEIN LACQUERS

I. PRINTERS'-INK AND LITHOGRAPHIC-VARNISHES

LINSEED-OIL is the material from which printers'-ink and lithographic-varnish are made. Only such oil may be used as does not "break" at 270° to 300° C. (515° to 570° F.). In the first place the oil is heated to 130° C. (265° F.) and held at this temperature as long as foam shows, or as long as the foam rises considerably; *i.e.*, as long as there is any moisture in the oil. Then the heat is run up to 270° to 300° C. (515° to 570° F.), and later yet to 360° to 380° C. (680° to 715° F.), which thickens the oil. According to the quality and quantity of the oil and the uniformity and steadiness of the heat, the oil will be brought to the required consistence in a longer or shorter time. To determine the progress of the operation, samples are taken from time to time and cooled quickly. In practice, the various grades (weak, medium, and strong) are tested by turning proof-glasses, and by testing between the thumb and forefinger; it can also be determined by an areometer which is allowed to sink in the liquid. Lithographic-varnish is always thicker than a similar grade of printers'-ink. The weak quality of varnish can be made in one hour, while the strongest requires 10 to 12 hours. The finished varnish

is strained in a half-warm condition through wire-cloth into a storage-tank.

Printers'-ink is usually made in a large iron kettle, set in brickwork, and generally has a hood to carry off the disagreeable vapor; four to six of these are grouped around one common chimney. If a copper kettle is used the product always has a greenish color.

The kettle may have a coil of pipe within, through which cold water may be run to quickly cool the contents; the flues in the brickwork are so built that the heat can come only two-thirds the height of the kettle, and moreover are provided with doors to let in cool air, by opening which the cooling of the kettle takes place rapidly. The furnace is fired from a chamber beneath, and the grate is sometimes on a truck, so that the fire may be withdrawn immediately. The rim of the kettle should be not more than 1 to 1½ metres (40 to 60 inches) above the level of the floor. A close-fitting, heavy iron cover, hung on chains which pass over pulleys, is a good protection against fire. The inside of the kettle must be kept smooth and clean, to lessen the color which the oil will take on. If warm, or even cold, air is blown through the oil, it will be thickened more rapidly and at a lower heat; in this way good varnish may be made with less expense for fuel. The best arrangement is to have a kettle not more than 1 metre (40 inches) deep, in the bottom of which, on supports, is placed an air-pipe with holes in its lower side, and the end of which comes up over the edge of the kettle and is connected with a compressed-air supply. A cock is provided to turn on or cut off the air, which may come from a warm room or be otherwise heated. Over the kettle hangs on chains suspended on pulleys a conical cover, having an opening for inspection; this is

two or three inches above the rim of the kettle, to let the vapors escape and yet prevent the hot oil from spattering out into the room. The fire is managed in another apartment.

The kettle is filled to within 10 cm. (4 inches) of the top, and the oil heated to 120° to 130° C. (170° to 185° F.) when the air-cock is opened a little, so as to let a little air be blown into the oil; then after a minute the cock is fully opened. If the air is cold, the temperature will go down at first, but then, from the action of the air on the oil, it will increase, so that very little fire will be required to keep it at 120° C. (170° F.) for pale oil; or the oil is thickened by a blast of warm air without any fire.

Recently it has been proposed to heat oil in a partial or complete vacuum; it is doubtful whether this method, advised by Lewiak and Ragovin, has been tried in a practical way, although it may be shown, by heating oil in a test-tube under reduced pressure, that it will thicken rapidly at a temperature below 300° C. (570° F.). Moreover, it is to be observed that the pipe for drawing off the contents of the kettle, as described, is liable to be clogged with oil-skins and scales, unless the pipe is removable.

Printers'-ink is made not only from linseed-oil (and nut-oil), but also with pale rosin combined with rectified rosin-oil and aged raw linseed-oil, with an addition of some rosin-soap and thick (natural) turpentine. To effect this, the rosin, broken into small pieces, is melted in a kettle together with rosin-oil at a temperature between 130° and 150° C. (265° to 285° F.), and then the fluid mixture of the linseed-oil and the other ingredients are added. To complete the combination the mixture is held at the above-named temperature for three hours, which produces a

homogeneous varnish, with as little as possible of the odor of the rosin-oil; to mechanically purify it, it is strained through a cloth. By suitably proportioning the three components, rosin, rosin-oil, and linseed-oil, varnishes of various degrees of strength and toughness may be made.

In making printers'-ink it is always to be noted that the final product must not be sticky, but tough and stringy; it must serve as a binder for whatever pigments are ground with it, and, without the addition of driers, must become dry in a limited time and must not strike through the paper. The most perfect inks are made from unmixed linseed-oil; the composite inks require allowances of one sort or another, and especially their odor is less agreeable.

Formulas for composite inks (parts by weight):

THIN VARNISH

Linseed-oil	13 parts
Rosin-oil	24 "
Rosin	21 "
Thick turpentine	$\frac{1}{2}$ part
Rosin-soap	$\frac{1}{2}$ "

MEDIUM VARNISH

Linseed-oil	10.5 parts
Rosin-oil	24 "
Rosin	21 "
Thick turpentine	$\frac{1}{2}$ part
Rosin-soap	$\frac{1}{2}$ "

HEAVY VARNISH

Linseed-oil	8.7 parts
Rosin-oil	24 "
Rosin	21 "
Thick turpentine	$\frac{1}{2}$ part
Rosin-soap	$\frac{1}{2}$ "

These varnishes may also be made with linseed-oil which, instead of being raw, has been heated with rosin to 300° C. (570° F.).

2. SOAP LACQUERS

Soap lacquers are characterized by peculiar qualities that fit them for certain uses; especially they are unacted on by water and are elastic, and also cheap; their qualities depend on the choice which is made of metallic salts which enter into their manufacture. The simplest way of making them is as follows: Good tallow soap is boiled with rain-water until it makes a clear solution, which when hot is filtered through several thicknesses of cloth. It is again heated, diluted with an equal volume of rain-water, and brought to boiling; then a boiling solution of alum (or sulphate of iron, copper, zinc, or other metal) is added to it until in the clear filtrate of a portion no further precipitate is produced by the addition of the salt. The precipitate is allowed to subside, the supernatant fluid is drawn off, the residue repeatedly washed with hot water and dried. After drying it is again heated in a water bath. The dry metallic soap is then dissolved in warm oil of turpentine (iron soap may be dissolved in benzine or other suitable solvent); the solution should have the body of a thick varnish. If on cooling it is too thick, it may be thinned with hot turpentine to the desired consistency.

Rosin-soap may be used as a cheap substitute for siccativ. To make it, 50 parts of soda are dissolved in 150 parts of water, heated to boiling, and with vigorous stirring 100 parts of powdered rosin are added; the whole boiled until the solution becomes clear and transparent. It is cooled, and the liquid is taken off from the brown, tough

rosin-soap which adheres to the bottom of the kettle. The finished soap is dissolved in water, and spirit of ammonia to the amount of 1 per cent of the weight of the soap is added. Colors are added to the solution as may be desired. The mixture dries rapidly and the film resembles a varnish. If to 1 part of such soap in 100 parts of boiling water a solution of 18 parts of slaked lime is added, it makes a quick-drying varnish (Fresson's compound) which can be used as gold-leaf varnish. If it is desired to have this varnish dry more slowly, 10 to 20 parts of glycerine (28° Bé.) may be added to it.

3. RESINATE VARNISH

According to the Müller-Jacobs method for making resinate colors, there should be combined 100 parts pale rosin, 10 parts caustic soda, 33 parts soda crystals, and 1,000 parts water, which are boiled together in a kettle and then the solution is cooled to 50° C. (122° F.). A filtered solution of a basic dyestuff is then stirred into it. After a time, during which the mixture is added to a solution of a metallic salt (*e.g.*, $MgCl_2$), the resinate color separates from the rest; it is then strained on a cloth to separate it from the solution, and dried.

The dry resinate color may be made of various degrees of strength, from 5 to 15 per cent of dyestuff; it is soluble in benzole, ether, chloroform, volatile oils, boiled linseed-oil, and also in varnishes made with alcohol, benzine, and turpentine. It is especially suitable for an addition to transparent oil-varnish or benzine varnishes. The following is a useful preparation: 30 parts thoroughly dry magnesium-resinate color are dissolved in 80 parts of benzole and 20 parts of chloroform, and mixed with 150 parts of a

clear solution of caoutchouc in carbon bisulphide and light coal-tar naphtha.

4. CASEIN VARNISHES

Casein may be used both for varnish and for paint. To make it, milk is allowed to stand and the cream is skimmed off until no more cream appears; then some vinegar or sulphuric acid is added to it and the casein separates in curdy masses. It is then washed repeatedly, carefully pressed, and then put into a flask and dissolved in spirit of ammonia, which is accomplished by digestion with frequent shaking in a closed flask for a few days. When this solution is spread on glass, wood, etc., the ammonia rapidly evaporates and the casein is left as a colorless, lustrous film, which appears permanent as exposed to the weather.

The addition of pigments to such a solution produces a paint.

Casein is also soluble in a solution of borax; a varnish may be made in this way, which dries rapidly and forms a satisfactory film.

CHAPTER X

NOTES ON VARNISH-MAKING

BY A. H. SABIN

FOR a general outline of the American practice of varnish-making, the reader is referred to Sabin's "Technology of Paint and Varnish"; but some supplementary remarks may be given in this place.

American methods seem to be more uniform among different factories than appears to be the case in Europe; while different makers vary in details, we have practically but one general style of apparatus, which consists in a furnace composed of a fire set just below the floor level, burning coke, coal, or gas, with a tall and spacious chimney to carry off the fumes as well as the products of combustion, no attempt to save the former being made; a cylindrical copper kettle with a flat bottom, about as deep as its diameter, having a loose cover, and holding 100 to 130 U. S. gallons; this kettle is set on, but not attached to, an iron wagon or varnish-truck, having three or four wheels, and drawn about by a long handle or tongue attached to the front axle. The resin, or "gum" as the workmen call it, is melted in the kettle, the cover being on; then the hot oil is added to it; then the cover is taken off and the mixture of oil and resin is cooked; then the kettle is drawn to the room or shed where it is to be thinned, and when suitably cooled the turpentine or benzine is added. Since turpentine has become so high in price, many of the factories have some sort of apparatus for recovering part or all of the turpentine vapor which is formed at first. A drawing is given of a very efficient condenser patented and used by G. W. Priest of Mansfield, Mass., which the writer has seen in operation and which is very satisfactory. With a suitable condenser not only is economy secured, but the most serious fire-risk is practically eliminated; all the fatal fires of which

the writer has heard have arisen when thinning the varnish. Varnish fires are unprofitable and unnecessary.

For purposes of computation and nomenclature, the unit amount of resin is assumed to be 100 lbs. In practice the

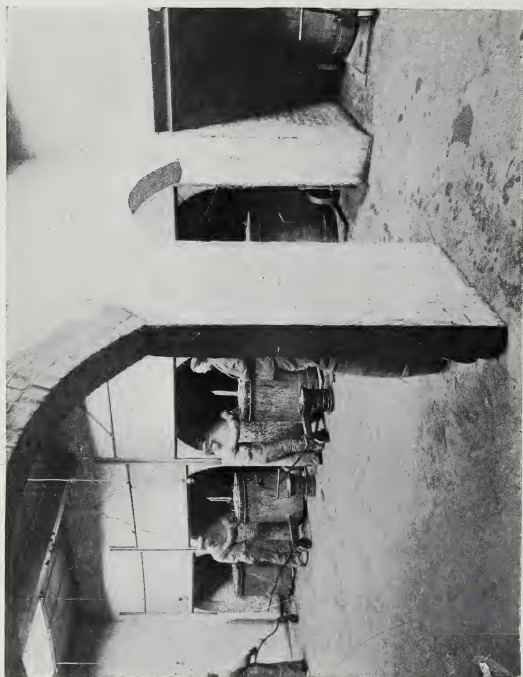

Courtesy of Lowe Bros. Co., Dayton, O.

FIG. 30.—An American Varnish-factory Melting-room or "Chimney."

quantity melted at one time is often 125 lbs. and sometimes 150 lbs. The amount of oil is reckoned as so many gallons to the 100 lbs. of resin as weighed before melting. The least proportion of which the writer has heard is three gal-

lons (about $23\frac{1}{4}$ lbs.) of oil to 100 lbs. of resin; a measured gallon of oil weighs about $7\frac{3}{4}$ lbs., although linseed-oil is sold in bulk by the conventional gallon of $7\frac{1}{2}$ lbs.; in the factory it is usually measured. The smallest propor-



Courtesy of The Louisville Varnish Co.

FIG. 31.—Another Typical Melting-room.

tion of oil ordinarily used is probably 8 gallons to the 100 lbs. of resin; rubbing-varnishes are often made in this proportion, though also made with 10 and sometimes 12

gallons of oil. Furniture-varnishes contain from 8 to 15 gallons of oil; floor-varnishes 14 to 18 gallons; in my opinion the best and most popular floor-varnishes contain 16 or 17 gallons; varnishes for doors, door-casings, etc., about 20 gallons; outside woodwork ("spar" varnishes) 25 to 30 gallons; carriage finishing, also 25 to 30. It will be seen that in all these the proportion of oil is much more than in the formulas given by Professor Bottler, who gives 10-gallon varnishes for floors and general woodwork, and some of his formulas call for so little oil that they are to all intents and purposes spirit-varnishes made with turpentine. It seems incredible that varnishes containing 10 gallons, and in many cases much less, of oil to the 100 lbs. of resin should be in general use for house-varnishes; yet substantially similar formulas are given by Coffignier in his (undated but recent) "Manual of Varnish Manufacture," by Laurent Naudin, and by Desalme and Pierron ("Colors, Paints, and Varnishes," Paris, 1910). The English, who are great varnish-makers, use formulas which are commonly believed to be like ours; in fact, our methods are based on English practice, and the English alone among foreign nations are still able to sell varnish here against our best makers.

Another notable difference between European practice and American is in the tendency in Europe to use thickened oil; that is, the oil is "boiled" until it has high viscosity; then when it is added to the melted resin it requires but little cooking before the volatile thinner is added, and the latter is used in larger proportion than is our custom. Our practice is to prepare the oil by some preliminary heating, but not to thicken it much; when the gum is combined with it we may thicken the mass considerably by cooking, but excessive cooking darkens it, and if heated too much it gelatinizes and is spoiled. The European practice enables the maker to thicken his oil more than we can, and when added to the resin it needs to be cooked only enough to make the ingredients stay together, and it will take more turpentine (or benzine). The European makers say that if not enough volatile thinner is used the film will be too thick, will skin over and not dry through,

and then will wrinkle; and that too much oil in a rubbing-varnish will make it "sweat," which means that when rubbed with pumice to produce a dull surface to which a



Courtesy of Lowe Bros. Co.

FIG. 32.—Putting in the Oil.

succeeding coat will adhere, it quickly becomes glossy again; if applied to a glossy surface a varnish does not take hold firmly, and on drying tends to "crawl" and become

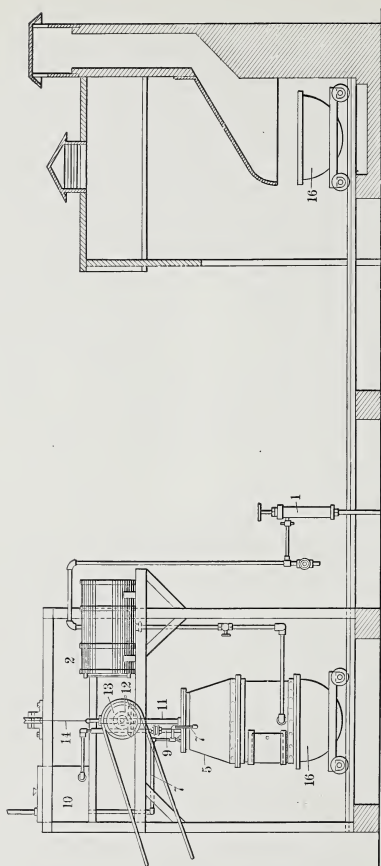

FIG. 33.—Priest's Condenser.

uneven. All this is true; yet our makers are in fact able to make good rubbing-varnishes with as high as 12 gallons of oil.

We believe, on the other hand, that the thickening of

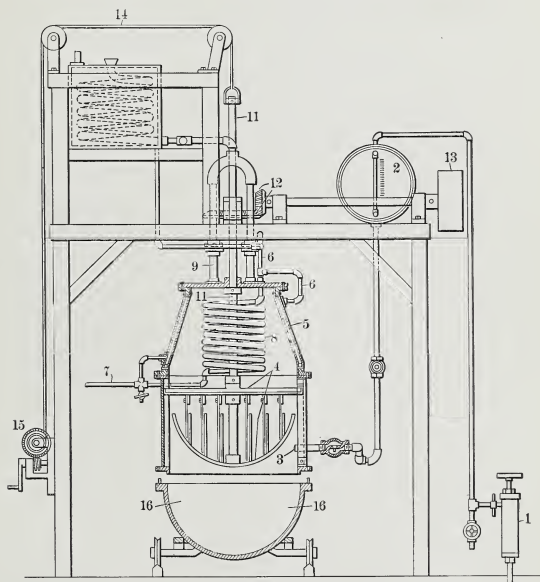

FIG. 34.—Priest's Condenser. 1. Naphtha pump. 2. Tank. 4. Stirrer. 11. Elevating shaft for same. 12, 13. Driving mechanism. 5. Cold-water jacket. 8. Cold-water coil. 15. Worm-gear for raising and lowering the condenser.

varnish should be done not in the oil-kettle but in the varnish-kettle, and that the prolonged cooking of the resin and oil together produces a better union of ingredients, and such varnishes are more durable than those made in the other way; in other words, a good varnish is a com-

pound rather than a mixture; and this is what I myself believe. I am inclined to believe, however, that there is more thickened oil used by American makers than was formerly the case.

Oil thickened by heat is called by the Germans "stand-oil"; by American makers it is more generally known as lithographic-oil. If made of well-bleached oil in an enamelled kettle, and, especially if by superheated steam, it is very pale in color; it is about as thick as molasses. Long cooking lowers the iodine number considerably and increases its specific gravity a little; it makes it dry better, if in a sufficiently thin film, and it dries with more gloss than ordinary oil. If it contains driers it may have a gloss almost like varnish, and, in fact, enamel paints are made with it.

Oil may also be thickened by blowing air through it. In this case either the oil is heated by a fire under the kettle or by steam, or else the air is heated by passing it through a superheater. Singularly enough, the results are different in these cases, though this fact is not generally known because the difference is not considerable unless the air-blowing process is carried further than is the common practice. If the operation is continued too long it results in the formation of a solid, extremely insoluble product. Another way to make solid oxidized oil (linoxyn) is to spray it on sheets of cloth hung up in a current of warm air; this is continued until the cloth is thickly coated with dried oil, which is from time to time removed by scraping; it is used for making linoleum and similar products, and is known as scrim-oil or Walton's oil (the last name from its inventor). A somewhat similar product is made by heating oil at a temperature running up to 630° F. several hours, when it gelatinizes, and is known as "sweetmeats," and is used by oilcloth-makers and for patent-leather varnish.

Oil thickened by air-blowing is oxidized, and dries better than raw oil; it is extensively used in making rosin-varnishes.

Rosin is a substance which is brittle, yet at ordinary summer temperatures it will flow; it may be considered a very thick liquid or a very viscous solid; but in any case it will

be easily understood that adding it to oil does not much thicken the latter. In making old-fashioned rosin-varnishes, therefore, only a little oil could be used with a



Courtesy of The Louisville Varnish Co.

FIG. 35.—Cooking the Oil and Resin Together.

great deal of rosin; and while such a compound was cheap it had no other good quality. But by using blown oil, if the oil is thicker than varnish, the more oil we add the

more "body" or viscosity the product has, and the more benzine we can add; and also the more durable it will be; and, as oil responds to driers, the more drier we can add, and the more quickly it will dry. By blowing oil vigorously at a temperature of 250° F. to 400° F. for fifty or sixty hours a product is obtained which will dissolve to a varnish consistency in its own volume of benzine (provided the latter is added before the oil is cold), and this can be made into a varnish with lime-hardened rosin and rosin drier (manganese resinate), which is suitable for use as insulating varnish or varnish for agricultural implements, and is very useful to add to more expensive varnishes to reduce their cost. It is really a very good varnish.

Rosin may be hardened by dissolving it in hot benzine or coal-tar naphtha, then agitating it with dry zinc oxide or dry caustic lime (powdered quicklime), until the rosin and zinc or lime combine. I have never found any advantage in using zinc rather than lime. But the more common way is to melt the rosin and add the lime to it. The acidity of this is tested by dissolving 5 grammes in 10 grammes of grain (ethyl) alcohol, and titrating it with decinormal caustic-soda solution, using phenolphthalein as an indicator. The ideal rosin-varnish would be neutral; but if enough lime is added to make it neutral it will be found that the rosin-lime compound is so hard and so difficult to fuse and to dissolve that it is impracticable to use it. The object to aim at is, therefore, to make a rosin solution as nearly neutral as possible.

Obviously it will be possible to dissolve a highly-limed rosin in a solvent of high boiling-point more easily than in ordinary benzine; and by using some of the new "mineral turpentine" solvents, having a high boiling-point, the rosin may be more highly limed than was formerly possible.

The object of liming rosin is to make it less sticky; it does not destroy its stickiness, but it lessens it, and more can be used. Tung or Chinese wood-oil is a valuable addition to these rosin-varnishes; this oil does not gelatinize on cooking if sufficient rosin has been added to it; and the addition of a not very large proportion of a well-cooked

mixture of rosin and this oil causes the varnish to be better in every way.

With the exception of some of the poorest grades, which go into cheap varnishes, most of the kauri resins come to the United States. In the last twenty years its price has increased about 250 per cent; while most other resins have increased 50 to 100 per cent. It is remarkable how the European experts persist in classing it with Manila and dammar, as a soft or semi-hard resin. It is the general belief in this country that it is the most desirable resin there is, taking all its qualities into account; certainly it is no more like Manila than it is like Zanzibar. Kauri varnishes are freer from "tricks" than any others, and are little if any less durable than the best. Zanzibar is probably a little more durable and has a higher lustre; but it is a much more difficult resin to handle, and its products are somewhat variable. The European classification of resins is not generally accepted in this country.

In the matter of apparatus we have much to learn. In the more densely-populated parts of the Old World it is not allowable to discharge the acrid fumes from varnish-making into the atmosphere, as is the custom here, and in consequence apparatus is in use which collects and condenses these products. More attention has, therefore, been given to the perfection of furnaces, kettles, etc., and in particular the use of enamelled kettles has become general. It is the opinion of the writer that the use of these, both for oil-boiling and varnish-making, would be a decided improvement. It is quite possible, also, that the use of aluminium kettles might be a gain. It might be necessary to make the bottom of a varnish-kettle of copper or, better, of enamelled steel, and bolt it on, as is done in Germany, so it could be easily replaced, with an aluminium body. This would not be much more expensive, and every copper-smith can work aluminium.

Attention is also asked to the German varnish-truck, used also in England, to lower the kettle on the fire and lift it off. With our heavier kettles this might require modification, but the idea is a good one, and could easily be developed. The writer submits drawings, secured by

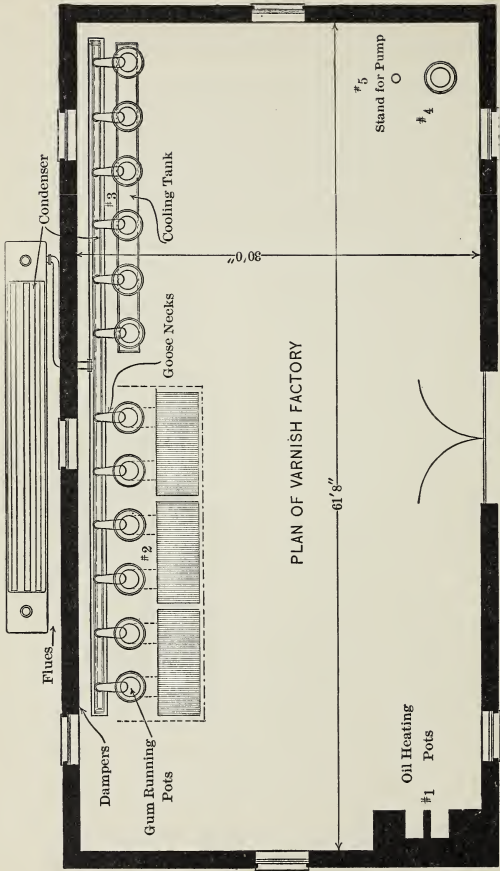

FIG. 36.—English Varnish Factory.

SECTIONAL ELEVATION OF VARNISH FACTORY

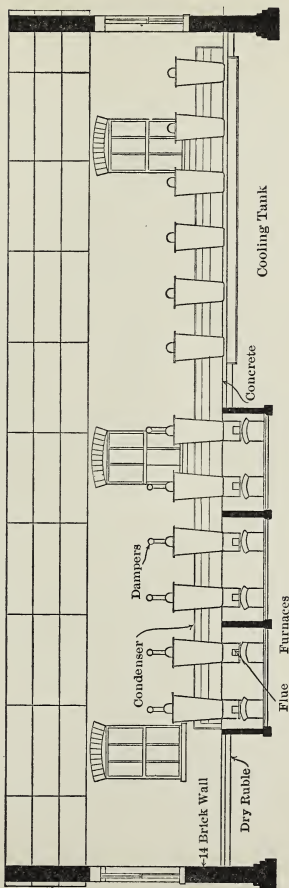

FIG. 37.

one of his friends at large expense, of a modern English factory; this is not an imaginary plan, but an actual and up-to-date factory.

Drawings of apparatus for gum-melting as distinct from oil-and-gum cooking are to be seen in most books on varnish-making, but it is not known to the writer that they have been used. It certainly seems as if an apparatus could be constructed to work continuously and with more uniform conditions than we now have, melting the resin and driving off just the right percentage with certainty

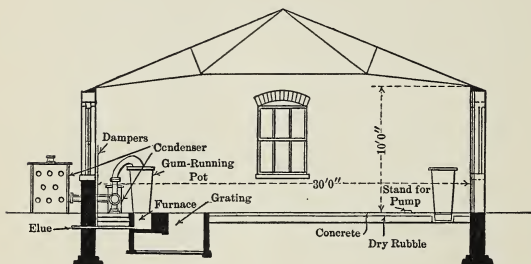

FIG. 38.

and with less dependence on the skill of the operator; the pale color of the more costly resins is easily injured by an extra minute or two in the kettle when the melting is completed. In general, 20 to 25 per cent of the weight of the resin is driven off during melting. Many attempts have been made to avoid this; but, as Professor Bottler says, they have not been successful; that is, some of them have been successful in getting the resin into solution, but the varnish so made has not been satisfactory. It appears to the writer that the fact is that a good oleoresinous varnish is to some extent a compound, and requires that the oil and resin should be heated together, almost to the point where they begin to suffer decomposition, before they properly combine; and the mixtures which have been

made of solutions of resin with oil are not seriously different from megilp, and like it undergo some separation when the volatile solvent evaporates. A resinous body like common rosin, or perhaps dammar, which is soluble in oil without melting, may make a tolerable mixture, but it is not to be compared with a varnish made in the ordinary way; but when a really hard varnish resin is used, we are dealing with things which are too essentially unlike and without affinity. It must not be forgotten that the product which we get by melting a resin such as kauri or Zanzibar is not part of the original resin from which a more volatile portion has been removed by heat; it is an essentially new substance, which was not in the original resin, but has been made from it, just as charcoal has been made from wood; and this pyro-copal, as it is called, is a resinous substance from which we make varnish by combining it, not merely mixing it, with oil.

That this is so is shown by the fact that if we melt kauri, or a similar resin, in a flask or retort, the temperature as shown by a thermometer in the melting resin is far higher than that of the vapor immediately over its surface; indicating in an unmistakable manner that a chemical dissociation is taking place, and new products are being formed. Part of the material which is distilled off is a permanent gas; it cannot be supposed that this was in the resin as a gas; and the rest is condensable to a series of liquids, having no resemblance in any way—odor, color, taste, or anything else—to the resin. The mixture of volatile liquids which comes off, and which may be separated into its constituents by fractional distillation, is what is called copal-oil; some portions of these ingredients are said to be of value as solvents, and this is probably the case.

It has long been known that the resin may be put without previous melting into the oil and dissolved by heat, but it is necessary to heat the mixture enough to melt the resin and decompose it; and in fact the varnish made in this way is not so good either in color or other properties as when made in the common way. The Bjerregard patents, referred to by Professor Bottler, were for certain modifications of such a process, and for certain apparatus, and were

used for a time in New York, but their use has been abandoned.

It may here be mentioned that considerable attention has been given in late years to attempts to make synthetic resins; so far as the writer knows these have been intended only for spirit-varnishes; also, in spite of numerous statements to the contrary, they have not proved valuable nor have they come into use except surreptitiously as adulterants for shellac and similar resins; chiefly shellac, as that is the only spirit-soluble resin of great commercial importance. The following historical review of the matter which brings the subject up to about 1908, may be of interest to any one who may care to look up the matter; since that date a great number of inventions have been made, the best-known of which are those of Dr. L. H. Baekeland, for which his numerous patents will give information, as is the case with other inventors. It should be said that these products are chiefly used in the solid state, as insulating material and the manufacture of other solid articles, and not as resins; their semi-resinous character leads people to attempt their use in varnishes, and it is by no means unlikely that in time useful preparations of this sort will be made. The great value of the solid products made by some of these processes seems to be beyond question; but their manufacture cannot be included in a book on the present subject.

Synthetic Resins: L. Grognot, *Rev. gén. chim.*, x. 49-54. Resins of Hlasiwetz, L. Barth, and Grabowski:—Artificial resin of benzoin. When phosphoric anhydride is added to essential oil of sweet almonds in sufficient quantity to make a syrupy mass, and if care is taken to avoid rise in temperature, it becomes of a yellowish-brown color and becomes hard at ordinary temperature in a few days. It is then washed with hot water; the excess of essential oil is expelled on the water-bath, and a resin is obtained which is soft when hot, brittle when cold, odorless, and having the appearance of colophony; it is purified by solution in alcohol and precipitating with water acidulated with HCl. This resin has a composition identical with that of the *a*-resin of benzoin; it is only partially soluble in

ether. From alcoholic solution it is precipitated by an alcoholic solution of acetate of lead. By dry distillation it produces a thick empyreumatic oil and much benzoic acid, with a carbonaceous residue. Melted with 4 parts of KOH it is decomposed into benzoic and *p*-oxybenzoic acids.

Eugenic Resin:—Following the method just described, phosphoric anhydride is added to eugenic acid until it takes the appearance of turpentine; the mass becomes red, and when exposed for some hours to a temperature of 50° to 80° it becomes a dark red and very hard. It is then washed with hot water, dissolved in alcohol, and precipitated with acidulated water. Eugenic resin is odorless, has the appearance of colophony, and an aromatic and bitter taste. Its alcoholic solution is dichroic, blue and violet. In the preparation of the resin, if an excess of phosphoric acid is used, a combination containing phosphoric acid is formed, from which the resin may be extracted by proper treatment. The composition of this resin is intermediate between eugenic acid, $C_{10}H_{12}O_2$, and a body of which the formula is $C_{10}H_{12}O_3$. On dry distillation it yields an oil with the odor of creosote and which gives a green color with salts of iron; part of the resin is carbonized. With HNO_3 it is converted almost wholly into oxalic acid; with KOH it yields chiefly protocatechuic acid and a little acetic acid. Some other essential oils treated with phosphoric acid behave differently. The essential oil of cassia is quickly attacked and produces a substance of a humic character. Essential oil of rue forms a deep brown resin, which melts imperfectly with KOH, and gives only traces of a crystalline substance which gives a violet color with salts of iron. Similar to this are the oils of angelica and of cumin. Guaiacol makes an oil which appears to contain phosphoric acid and when melted with KOH gives protocatechuic acid in abundance. The stearoptene of the essential oil of anise, $C_{10}H_{12}O$, treated with iodic acid and iodine with the addition of potash, is transformed at a moderate heat into a brown resin of which the composition differs little from the stearoptene, except that it contains a little more oxygen. This resin melted with potash produces

only a little of a crystalline substance which seems to be anisic acid. (Ann., 139, 83 [1886].)

Resins of Barth:—The researches of this author were made on the essential oils of turpentine, lavender, and juniper. These oils were treated with alcoholic potash, and the resultant deep yellow liquid evaporated in a water-bath, the residue treated with dilute H_2SO_4 and digested in ether. The ether being distilled off, there remained a resinous body. After being acted on three or four hours by potash, the essential oil was found to be transformed into a hard, brittle resin resembling colophony. Camphor also produces a resin, and this is always found in slight quantity in the preparation of camphoric acid by Berthelot's method. This is a golden yellow resin, quite inodorous after having been heated to 100° ; it remains like pitch for a long time. The resins of turpentine and of lavender appear to be $C_{20}H_{30}O_3$; that of camphor, $C_{20}H_{30}O_2$. The resin of turpentine is attacked with difficulty by potash and is only slowly oxidized. The products of oxidation are the lower fatty acids and of a composition analogous to camphoresinic acid (*Bull. soc. chim.*, 1868, 70). The tannins are related to the resins, since their products of decomposition are often resinous. In certain compounds resin appears to replace the glucose of glucosides; thus colchicin, the active principle of colchicum, decomposes easily into a resin and colchicein, without the formation of glucose. Resins produced from essential oils, as far as we can judge, are created by processes similar to those of nature. But when we consider those produced from aldehydes and phenols, we open a new field.

Aldehyde Resin of Wurtz:—The aldehyde, CH_3CHO , treated with HCl forms an unstable compound, $CH_3.CH(OH)Cl$, which reacts upon another molecule of aldehyde to make aldol with reformation of HCl , which may be considered a catalytic agent. $CH_3.CH(OH)Cl + CH_3.CHO = HCl + CH_3.CH(OH).CH_2.CHO$ (aldol). Two molecules unite to form aldol, intermediate between aldehyde and alcohol. In the distillation of this aldol, resins are produced by the condensation of two or more molecules of aldol. These resins are pale or brown, according to the

degree of heat employed. A temperature of 60° is sufficient to effect a change in some samples of aldol, which becomes insoluble and sometimes on cooling hardens into a glassy solid. These experiments on aldol by Wurtz are of considerable interest, since we now know how to produce economically the aldehyde and aldehydes in general by practical methods; thus, according to Duoy-Hénault, it is possible by electrolysis to convert alcohol quantitatively into aldehyde: $\text{CH}_3\text{CH}_2\text{OH} + \text{O} = \text{CH}_3\text{CHO} + \text{H}_2\text{O}$. The potential necessary varied in different electrolyses from 0.7 to 0.9. With an anode newly platinized it was found to be 0.37. Ethyl-sulphuric acid will be produced only when the tension at the anode is excessive. According to Sabatier (*Rev. gén. chim.*, 24 [Dec., 1905]), vapors of primary alcohols coming in contact with copper at a temperature of 300° are completely separated into aldehydes and hydrogen which latter escaped from the apparatus. Similarly secondary alcohols are separated into hydrogen and acetones. This is a very advantageous method. Propyl, isobutyl, and isoamyl aldehydes are thus easily obtained pure (*Rev. gén. chim.*, 24 [Dec., 1905]). Finally Jonas, Desmonts, Dubosc, and Deglatigny have worked out a later method by following out the investigations of Kutscheroff (*Dict. de Wurtz*, 2d Supp., acetylene, p. 86). Acetylene combines readily with mercury salts in aqueous solutions, forming products insoluble in the liquid. These compounds spontaneously decompose at ordinary temperatures, more rapidly if heated, into acetic aldehyde and the original mercury salt, so that a very small quantity of the latter will hydrate an indefinite quantity of acetylene. Dilute H_2SO_4 , (sp. gr. 1.32) transforms, in the cold, aldol into a white amorphous substance insoluble in water, from which it is possible, though difficult, to isolate two distinct compounds, fusible at 70° and 80° respectively (Lobry de Bruyn).

Resins formed from aldehyde and phenols:—According to the investigations of Baeyer and his pupils, a molecule of aldehyde acting on two molecules of phenol in the presence of HCl or H_2SO_4 produces a substance whose composition corresponds to one molecule of aldehyde united to two molecules of phenol with the elimination of one

molecule of water: $\text{CH}_3 \cdot \text{CH}(\text{C}_6\text{H}_4\text{OH})_2$. *a*-Naphthol combines with benzoic aldehyde to form benzylidenedi-*a*-naphthol, a white powder, $\text{C}_6\text{H}_5\text{CH}_2(\text{C}_6\text{H}_4\text{OH})_2$. The aromatic aldehydes act also on the polyatomic phenols; in the presence of HCl or H_2SO_4 , aldehyde forms with resorcinol a benzylideneresorcinol, $\text{C}_{26}\text{H}_{20}\text{O}_4$, a colorless resin, insoluble in water, easily soluble in alcohol, ether, or benzine; fusible at 330° with decomposition (Michael, *Am. Ch. J.*, 5, 340, and *Dict. de Wurtz*, 2d Supp., 161).

Resin of Kleeburg:—Formic aldehyde acts on phenol, resorcinol, or pyrogallol in the presence of concentrated HCl, giving products insoluble in alkalies, the purification of which has not been possible. Gallic acid gives a better result. To 20 grammes of this acid dissolved in hot water is added 40 c.cm. formalin, then HCl until a precipitate is formed. Upon cooling it deposits a brown resin and an amorphous, colorless body almost insoluble in water or alcohol. It is an acid, $\text{C}_{16}\text{H}_{12}\text{O}_{10} \cdot 2\text{C}_7\text{H}_6\text{O}_5 + 2\text{CH}_2\text{O} = 2\text{H}_3\text{O} + \text{C}_{16}\text{H}_{12}\text{O}_{10}$. It gives with phenyl-hydrazine a crystalline salt, $\text{C}_{16}\text{H}_{12}\text{O}_{10} \cdot 2\text{C}_6\text{H}_5 \cdot \text{N}_2\text{H}_3$, from which the amorphous acid is reprecipitated by HCl; it becomes crystallized by prolonged boiling in alcohol. Boiling an ammoniacal solution of the acid precipitates a reddish crystalline salt, $\text{C}_{16}\text{H}_{12}\text{O}_{10} \cdot \text{NH}_3$ (*Bull. soc. chim.*, April 5, 1892, p. 305). This action described by Kleeburg is the starting-point from which we proceed to the actual production of new resins. Trillat has shown that the combination of formic aldehyde and the phenols in the presence of concentrated sulphuric acid (and the like) gives in general products which are amorphous, resinous, insoluble in all reagents, and some of which have the appearance of cellulose. Not only do the phenols react with formic aldehyde, but also certain hydrocarbons. The action of 40-per-cent formalin upon benzene has been discussed by Nastukof. If to a mixture of one volume of formalin and two volumes of concentrated H_2SO_4 is added two volumes of benzene, a yellow amorphous body is obtained. Genvresse has obtained addition-products by combining, molecule to molecule, formic aldehyde with caryophyllene, clovene, and cadinene (*Rev. gén. chim.*, 22, 28 [Jan., 1905]).

Blumer, Artificial Shellac:—An organic hydroxy acid, such as tartaric, as the agent of condensation, in the state of a saturated solution in formalin; then phenol or *a*-naphthol is added and the mixture heated to the boiling-point, when products are formed which are resinous solids, resembling lac. Example 1: A spacious lead-lined steam-jacketed kettle is charged with 155 kg. commercial tartaric acid, and 150 kg. of 40-per-cent formalin. The acid dissolves completely at a gentle heat; then 195 kg. of 100-per-cent phenol are added and a moderate heat is maintained until the reaction begins; while the reaction continues, which is about ten minutes, the contents of the kettle are kept in a state of lively ebullition. When the action ceases the resin floats on the surface as an oily liquid; this is removed and put into hot water where it is purified by washing (with the addition of a little ammonia) from traces of phenol and formalin which may adhere to it. It is then turned into cold water, when it immediately hardens and solidifies in white flakes like natural lac. Example 2: With *a*-naphthol, the charge is 155 kg. tartaric acid, 150 kg. formalin, and 290 kg. *a*-naphthol. The reaction is very violent and there forms on the surface a red resin which hardens rapidly. It is treated as before; but this resin does not melt under water. There is a combination of 3 molecules of phenol with 3 molecules of formaldehyde, and separation of 2 molecules of water; and the resultant mass has the formula, $C_2H_{20}O_4$. It is the same with other organic acids; but it is necessary to use them in large quantities, otherwise they will give rise to various products not industrially valuable. With inorganic acids like results are had, but it is necessary to enfeeble the reaction. The dilute acid is mixed with the phenol, heated, and the formaldehyde is added gradually, just fast enough to keep the contents of the kettle in ebullition (*Rev. prod. chim.*, March 15, 1904).

Transparent Resin of De Laire (Pat. 361539, June 8, 1905, published July 31, 1906):—When the crude product of the combination of the phenols with formaldehyde, aldehyde, and the like, is submitted to the action of heat, a certain quantity of water is eliminated, and resinous

products are formed, capable of replacing amber and lac, their qualities being analogous to those of natural resins. Some precautions are necessary. This combination may be made according to described methods, using either acids or alkalis as reagents. It has, moreover, been found possible to combine aldehyde and phenol directly, by heating them in an autoclave. After obtaining the product in the manner which has been described, and when it is well washed, it should be heated in the open air at a temperature above 100° . The time of heating the mass, after it is melted, varies according to the temperature; from half an hour at 150° to ten or twelve minutes at 200° ; at the beginning of the heating a marked coloration is produced, then the elimination of steam is observed, and finally the substance which was opaque and fluid becomes viscous and transparent. On cooling, it is obtained as a solid block looking like amber, but of which the physical properties, color, hardness, solubility, melting-point, etc., vary according to the nature, the purity, and the proportions of the materials employed, and also according to the manner in which the combination has been effected. Example 1: Agitate for some time a mixture of 5 to 10 parts of 40-per-cent formalin, 10 parts commercial white distilled phenol, and about 10 parts hydrochloric acid containing 15 per cent HCl. After removing by washing the excess of HCl and phenol, a plastic mass is obtained, which is heated in the open air or in the presence of an inert gas until it looks like melted pine resin, and until a sample taken out does not cloud up on cooling and hardens rapidly. This effect may be obtained after heating half an hour at about 140° . It is indeed possible to heat to 200° without danger; only the resulting product will be colored light brown. After cooling the mass is a hard resin of which the color is from yellow to a brilliant brown, resembling amber, transparent as glass, and soluble in ethyl and methyl alcohol, and in caustic alkali. Example 2: 300 parts of crude cresol are dissolved in 20,000 parts of a 10-per-cent solution of KOH, and to this is added 300 parts of commercial formaldehyde. When the odor of formaldehyde has nearly disappeared, add acid to a faint acid reaction; a precipitate

is formed which is to be washed with water. The crude product thus obtained is introduced into an apparatus for distillation, a vacuum is produced, and the mass is gradually heated nearly to the point of ebullition; the heat is kept up until the water is removed. On cooling a hard transparent mass is obtained, soluble in ethyl alcohol and in caustic alkali. In the first example we may employ either a vacuum or a pressure above that of the atmosphere. To these reactions of formaldehyde may be added those resulting from its action in the presence of lime or baryta upon phenacetylaldehyde, diphenylacetone, etc., giving resinous products (*Rev. gén. chim.*, 1903, 348). Nitric acid reacts on furfural forming a resinous substance. Finally, guanidine, $\text{NH}=\text{C}(\text{NH}_2)_2$, which is easily obtained from gelatine by oxidizing with calcium or barium permanganate, is energetically attacked in concentrated aqueous solution by common aldehyde, and a resinous mass is obtained. (From *Chemical Abstracts*, vol. i., pp. 1179-82.)

A valuable report on Manila resin, in part by Brooks, part by Richmond, appeared in May, 1910, in the *Philippine Journal of Science*, vol. v., No. 3, Section A; which deserves careful study by any one interested in chemical work on varnish resins. These papers are too long to be reprinted here, but their scope is briefly and insufficiently indicated by the following abstracts, prepared for *Chemical Abstracts*. The original papers should be consulted.

The Study of Manila Copal: P. C. Freer, *Philipp. Jour. Sci.*, v., 171. Manila copal is derived from *Agathis alba* (Lambert) locally called the almaciga tree, a conifer, 50-60 m. high, 1 to 2 m. diameter, which grows in Luzon and other islands, at 150 to 2,000 m. above sea-level, and is known by several botanical and many native names, and shows varieties which have been regarded as species. The copal is composed chiefly of amorphous resin acids, with a small proportion of a neutral, amorphous solid, which remains after exhausting with alkalis, and which darkens rapidly on melting and probably causes deepening of color in varnish-making. It also contains a small percentage of terpenes. The resin rapidly oxidizes on exposure to the air, but the acids do not oxidize by themselves. If pow-

dered, it gives off CO_2 at ordinary temperatures, more rapidly if exposed to sunlight; but the hardening of the freshly-exuded resin is not due to oxidation.

Manila Copal: G. F. Richmond, *Philip. Jour. Sci.*, v., 177. This is a collective term for medium-hard resins from the Sunda, Philippine, and Molucca Islands, known also as "almaciga," Spanish for gum mastic which is an entirely different resin. It comes from *Agathis alba*, which has bark 1 cm. or more in thickness, smooth, with numerous resin canals, and the resin is derived from wounds or incisions in the bark. The wood is light-colored and contains resin cavities; leaves ovate-lanceolate, mostly opposite, 2-12 cm. long, 1-4 cm. broad, cones often 10 cm. diameter. The tree has also been known as *Dammara orientalis*, *D. alba*, etc., but the copal is quite distinct from dammar resin, and the tree is closely related to the kauri pine, *Agathis robusta* of New Zealand, which is also known as *D. australis*. True dammar resin is probably from dipterocarpous, not coniferous, trees (Tschirch). As collected by the natives, these and other resins are mixed, but are separated, by sorting, by the dealers. Much of the resin is obtained by cutting off strips of bark; the fresh resin exudes from the cut edges, colorless at first, rapidly hardens, and the later exudations force the earlier outward by depositing underneath; thus the surface is always hard, and the hardening process is slow. Broken branches exude resin, and cut roots are a considerable source of supply. Recent resin is pale yellow, old or mineral resin is reddish-brown. Acid values were found by dissolving, as nearly as possible, 1 gm. in 50 c.cm. absolute alcohol and adding $\frac{N}{2}$ alcoholic KOH, and phenolphthalein, expressed as mg. KOH for 1 gm. resin; saponification number by heating a similar soluble on water-bath with 25 c.cm. $\frac{N}{2}$ KOH for one hour and adding $\frac{N}{2}$ alcoholic HCl, expressed as KOH as before. The surface resin was incompletely soluble in absolute alcohol, the mineral resin completely soluble.

	Acid No.	Saponification No.
Fresh resin, pale yellow	128.1	177.8
Mineral resin, brittle, white	109.0	148.0
“ “ “ dark brown	105.7	145.3
“ “ soft, white	134.2	184.4
“ “ “ dark brown	131.1	181.2

Neutralized with alkali and distilled the fresh resin gave volatile oil 1.3 per cent; the mined resin, 8 to 11 per cent. The resin acids appear monobasic and correspond approximately to $C_{10}H_{15}O_2$, $C_{22}H_{34}O_4$, and $C_{32}H_{50}O_4$, the latter probably not from pure enough material to be correct. The copal also contains a neutral saponifiable substance, probably a lactone, and an unsaponifiable resin. Results do not agree with Tschirch and Koch. Serviceable varnish was made of Manila copal, Lumbang (tung) oil, and Benguet turpentine (fr. *P. insularis*), all local products.

Destructive Distillation of Manila Copal: B. T. Brooks, *Philip. Jour. Sci.*, v., 203. H_2O is steadily given off, as a product of decomposition, up to 330° ; frothing occurs up to this point; the loss is 12 to 14 per cent of the original sample, the soft pieces lose most; the temperature of the gases given off is not above 200° . When the temperature reaches 340° the distillate is at 330° and gradually rises. Below 330° the products are resin-oil, pinene, β -pinene, limonene, dipentene, camphene, water, formic acid, acetic acid, methyl alcohol, acetone, acetyl formaldehyde, formaldehyde, furfuraldehyde, CO_2 , saturated and unsaturated hydrocarbons, and probably acrolein. Small pieces of resin yield less volatile oil than large ones, and old less than fresh samples, indicating that changes due to exposure lessen the amount of terpenes; which vary from about 11 per cent in soft fresh pieces to less than 4 per cent in small hard pieces; 78.7 per cent of the volatile oil boils 155° - 162° and consists mainly of pinene; other fractions were: 162° - 168° =8.6 per cent.; 168° - 170° =3.2 per cent; 170° - 180° =6.4 per cent; residue 3.2 per cent. Of the uncondensed gases given off below 330° , CO_2 was constant at 92.6 per cent; at higher temperatures less CO_2 , and in-

creasing amounts of unsaturated and saturated hydrocarbons and CO. The total CO₂ was 3.2 per cent of the weight of resin, and is probably from decomposition of a hydroxyl group. The amount of H₂O collected by distillation was 2.4 per cent of the weight of resin. Formic and other volatile acids, about 0.5 per cent, were collected with the H₂O; also formaldehyde, etc. The darkening of the resin is not due to oxidation, but probably to the carbonization of some of the contents. Numerous experiments are described; boiling with reflux condenser 0.5 hour, using 100 c.cm. solvent and 10 gm. powdered resin which had been heated to 300° showed solubility in ethyl alcohol = 95 per cent; amyl alcohol = 97 per cent; ether 75 per cent; ligroin, 32 per cent; benzene, 50 per cent; turpentine, 46 per cent.

Oxidation of Manila Copal by the Air; B. T. Brooks, *Philipp. Jour. Sci.*, v., 219. It readily oxidizes in the air, and this is accelerated by sunlight; it is accompanied by an increase in the Koettstorfer number. The resin acids undergo similar, but slower, oxidation. CO₂, formic acid, H₂O₂, and formaldehyde are evolved, and are probably due to the breaking down of oxidation products; *i.e.*, oxidation comes first. Digestion with alcoholic KOH causes high Koettstorfer numbers. (True of about everything which has a K. no.; *Abstractor*.) The claim is made that formaldehyde has not previously been noted as a product of oxidation of organic substances by the air.

PATENT-LEATHER VARNISH

The varnish used on patent-leather is different from all others, partly because it is black and this admits the use of iron compounds for driers. It contains no resin, but the oil is cooked until when dry it shows a brilliant varnish lustre; at the same time it is flexible. It is made by heating oil with about 4 ounces of Prussian (or Chinese) blue to the gallon of oil, at a temperature of about 570° F., for four to six hours. The amount of blue used is sometimes as high as 4 per cent, which would be about 5 ounces. The effect of the prolonged heating in a strongly reducing

substance like linseed-oil is to decompose the blue, which is a cyanide, and contains about 57.6 per cent of its weight as iron; or the iron is not far from 2 per cent of the weight of the oil. Oil is capable of taking up about 5.5 per cent of Fe. The iron thus dissolved in the oil acts as a powerful drier. It is possible to make an oil-iron soap, by saponifying the oil in the usual way with NaOH, and to the solution add FeSO₄ solution; the precipitate is dried and dissolved in more oil, exactly as in making a manganese drier. Such a solution is black in color, but is a most powerful drier.

Yellow or light-colored patent-leathers are not varnished with this compound, but with an oleoresinous varnish, best made from Zanzibar resin, containing 30 or 40 (or more) gallons of oil to the 100 lbs. of resin.

The basis of all patent-leather work is a bottom coat, called a daub coat, made by boiling linseed-oil at a high temperature for a considerable time until it has a consistency like india-rubber which has become swollen by absorbing naphtha. The oil is boiled with a slight amount of driers, usually raw umber. The boiling is carried as far as possible and yet have naphtha mix with it. This preparation is thinned with naphtha to suit the requirements of different types of leather and serves as a filling coat. It is applied with a curved blade, about 9 inches long, called a slicker. The next step is a light coat of varnish which serves as a basis for a heavier coat of the same material.

All pigments used are in the bottom coats; the varnishes contain no color except in the case of some fancy and automobile leathers.

The varnishes are made by cooking linseed-oil with Chinese blue at a high temperature as already described. When the oil has reached the desired consistency, which is usually that of molasses, sufficient naphtha is added to make the varnish flow readily. The leather is stoned with a pumice-stone between coats and the leather well sprinkled with water before the varnish is applied.

The bottom coats are dried in drying-ovens at a temperature of about 120°. The final varnish is dried in ovens at about 170° and exposed to sunlight for several hours to remove a slight tackiness from the finished product.

On fine kid skins, a mixture of collodion and boiled oil is used as a bottom coat, which is applied with a sponge. This makes a very flexible and durable coat and takes the place of the daub coat, mentioned above; the varnishes on either type of leather being the same.

Before applying a bottom coat, all grease is extracted from the chrome-tanned leather by washing the leather in naphtha in large tanks prepared for the purpose.

This description is confined to chrome-tanned leather as the bulk of patent-leather in America to-day is made from chrome-tanned stock.

The furniture and automobile leather alone are vegetable tanned. This leather does not have the grease extracted from it.

Up to about 1900, all patent- and enamel-leather was made from vegetable-tanned leather. The main idea was to secure a leather which was strong and mellow, but which had a very slight amount of greasy matter in it. As the leather had to be subjected to a temperature of some 170° F., considerable skill was required to tan the leather properly.

For furniture and carriage leather, immense hides were used. The grain which was hard and brittle was first split off, leaving underneath some of the epidermis. The leather was then split into two or three thicknesses. The horny grain part, which had been split off first, was discarded by the patent-leather man and sold for bookbinding and ornamental purposes. The next layer was called the grain and was finished up for the best furniture and carriage leather, while the splits were used for various inferior purposes, such as dashboards and mud-guards.

Germany and France excelled in shoe-leather. This leather was made on the flesh side, the grain part of the skin being next to the foot, in shoes.

About 1900 the American tanner perfected chrome-tanned leather so that the grain was flexible enough to hold a japan and, from that time, little or no imported patent-leather has been used in America.

At the present time, America leads the world in the manufacture of patent-leather.

CHAPTER XI

PAINT; ITS CONSTITUTION AND NATURE

BY A. H. SABIN

LIQUIDS which contain solid particles in suspension, and which are made for decorative or protective coatings on solid surfaces, are paints. The liquid portion of a liquid paint is called the vehicle, and is essentially a sort of varnish; that is, when exposed in a thin film to the action of the air it becomes a solid, either by evaporation or chemical change, or both; in its liquid state it serves as a medium for the approximately uniform distribution of the solid particles which it holds in suspension, and when it has solidified it serves as a cementing or binding material to hold them in place; in this way it acts as a binder, and is often spoken of as such. The most common paint vehicle is linseed-oil.

The solid particles in the liquid paint are collectively called the pigments. Pigments are solids in a state of fine subdivision, either because they have been so formed chemically, as chemical precipitates, or have been mechanically comminuted. Those which are made by grinding are usually so fine that the greater part will pass through a wire sieve of 200 meshes to the linear inch; they are sometimes sifted or bolted, but oftener are ground in a mill until fine enough and used without sifting, in which case they may contain as much as 5 per cent (usually less) of relatively coarse particles; such, for example, as will not pass a 100-mesh sieve. On the other hand, all pigments contain more or less exceedingly small particles; a large proportion of the particles of white lead are less than 0.00001 inch in diameter, and probably the greater part of zinc oxide and sublimed lead-sulphate are as fine as that.

These very fine particles are the most valuable part of the

pigment; it being a general rule that when we consider different grades of the same pigment the finer it is the better. It does not follow that a poor pigment can be made into a good one by being finely ground; moreover, products of the same chemical composition may vary in pigment value according as they are amorphous or crystalline as well as according to fineness. Crystalline and amorphous states may affect solids more radically than is commonly supposed; thus, crystalline sulphur differs in many important respects from amorphous sulphur, graphite and diamond from amorphous carbon, and crystalline from amorphous quartz, the latter even after they are melted, although melting is usually thought to destroy crystalline structure. The value of pigments is a difficult, complex, and obscure subject; while we have considerable empirical knowledge of it, the reasons why values differ have not yet become thoroughly known, and do not constitute a matter for dogmatic prediction. Thus, if we consider the subject of a strictly protective, not decorative, coating for iron, all the writer's prejudices lead him to believe that precipitated barium-sulphate, with its very minute particles and extreme chemical stability, must be a most desirable pigment; on the other hand, all our empirical knowledge seems to prove that it is not merely worthless but injurious.

As to the relative proportions of pigment and oil it may be said that the oil is, roughly speaking, about three (sometimes four) times the volume of the pigment.

Since the pigment consists of a vast number of particles, with spaces between them, it is not easy to measure pigments by volume; if we know the specific gravity of the pigment we may determine its volume by weighing; in fact, this is what we practically are compelled to do. As it may not be obvious to the reader how to determine the specific gravity of a pigment, it is well to describe the operation.

The apparatus used consists of a 100 c.cm. stoppered glass flask with narrow neck, a short-stemmed 2-inch funnel, a stiff piece of brass wire, and a burette having 100 c.cm. capacity, the lower part of which is graduated in fiftieths of a c.cm., being nearly 30 inches long and

about $\frac{3}{8}$ -inch diameter; above this slender graduated part is a spherical bulb of nearly 80 c.cm. capacity, then above this a neck on which is the 100 c.cm. mark, terminating upward in a funnel.

To find accurately the capacity of the flask, it is filled from the burette with kerosene-oil which has previously been filtered, letting the burette drain for fifteen minutes before taking the reading; this precaution should be followed in each determination. The burette is read in fiftieths, which may be reduced to hundredths by multiplying by two. Take note of the temperature of the room and regulate the ventilation so that it will not vary. It is most convenient to work at ordinary room temperature, say 20° or 21° C. The oil and the apparatus should be in the room for some time before starting the determination.

Weigh out 100 grammes of the pigment, if it is a heavy one; if a light one, less; as little as 25 grammes may be enough. Place the weighed portion in the 100 c.cm. flask by running through the short-stemmed funnel, using the wire if necessary to aid in getting it through the neck of the funnel. If desirable, the flask may be weighed before and after the addition of the pigment in order to accurately find the number of grammes in it. Fill the burette with kerosene-oil, and run the latter into the pigment until the oil is level with the 100 c.cm. mark on the neck of the flask; then put in the glass stopper and hold the neck of the flask between the palms of the hands, moving one hand back and forth so as to give the flask a rotary movement, and wetting the pigment thoroughly with the kerosene-oil. To displace the last trace of air-bubbles, tap the flask gently on a cloth-covered surface. After this, remove the glass stopper carefully, letting any kerosene that may adhere to it run down into the flask. Make the volume in the flask up to the 100 c.cm. mark, adding more kerosene from the burette. This operation should be repeated until the rotating motion and the tapping do not change the apparent volume in the flask, denoting that all the air has been displaced. When the volume in the flask is constant, let the burette drain for the required time, then take reading.

A . . . Capacity of flask.

B . . . Reading of burette.

C (= *A* - *B*) . . . Volume of pigment in flask.

D . . . Weight in grammes of pigment used in determination.

E . . . Specific gravity.

$$E = \frac{D}{C}$$

To remove the kerosene from the flask after each determination, rinse the flask twice with ether and dry with a current of air.

It will now be seen why the apparatus is constructed as has been described. The volume of pigment taken should be less than 20 c.cm., but the flask must have a capacity of 100 c.cm. in order to be able to agitate the mixture of pigment and oil enough to get all the air out. The burette must therefore have a capacity of 100 c.cm., $\frac{4}{5}$ of which will be run into the flask every time and therefore can be contained in a bulb, without graduation; and the long, slender bottom part is very finely graduated, giving accurate readings.

Using this method, the following specific gravities have been found:

Red lead	8.70
Orange lead	8.89
Orange lead, American	8.97
Litharge	10.00
White lead, Dutch process	6.6 to 6.83
White lead, Carter process	6.78
Sublimed lead sulphate	6.30 to 6.45
Sublimed blue lead sulphate	6.39
Lithopone	4.26
Zinc-lead white	4.42
Bright red oxide of iron	5.26
Indian red	5.26
Venetian red	3.10
Prince's metallic oxide	3.17
Natural graphite	2.60
Atcheson's graphite	2.21
Bone-black	2.68
Lampblack	1.82
Carbon-black	1.85
Willow charcoal	1.49

Mineral black.....	1.69
Keystone filler.....	2.66
White zinc.....	5.4 to 5.56
Ochre.....	2.94
Sienna.....	3.26
Umber.....	3.57
Barytes.....	4.23 to 4.46
Blanc fixé.....	4.23
Whiting.....	2.65 to 2.74
CaCO ₃ precipitate.....	2.56
Gypsum.....	2.29 to 2.33
China clay.....	2.62 to 2.67
Asbestine.....	2.75
American vermilion.....	6.83
Orange chrome-yellow.....	6.90
Medium chrome-yellow.....	5.88
Lemon chrome-yellow.....	6.25
Barium chromate.....	4.65
Zinc chromate.....	3.57
Zinc and barium chromate.....	3.45
Chrome green, blue tone.....	4.44
Chrome green, yellow tone.....	4.03
Neutral Prussian blue.....	1.94
Ultramarine.....	2.40
Silica.....	2.64

To find out how many pounds of a given pigment are required to make 1 gallon, *i.e.*, when added to a known quantity of oil to make a mixture measuring 1 gallon more than the oil alone, multiply the specific gravity by 8.33 (which is the weight of one U. S. gallon of water). Thus, suppose white lead has specific gravity 6.6. Multiply this by 8.33 equals 55; or if we put together 55 lbs. of dry white lead and 3 gallons of linseed-oil we will have 4 gallons of paint; and if the specific gravity of the oil is .93, the 4 gallons of paint will weigh about 78 lbs. or 19½ lbs. per gallon, and each gallon will contain 13¾ lbs. dry white lead and 3 quarts of oil.

Again, the specific gravity of silica is 2.64. This multiplied by 8.33 equals 22 lbs. for a gallon of silica. If we add this 22 lbs. silica to 3 gallons of oil, as before, we have 4 gallons of paint weighing 45 lbs., less than half the weight being silica. Now, if we undertake to make a paint containing by weight 90-per-cent lead and 10-per-cent silica

(in the pigment), instead of adding $\frac{1}{10}$ of a gallon of our silica-paint to $\frac{1}{10}$ of a gallon of our lead-paint, we must add $\frac{2}{10}$ of a gallon of the silica-paint to $\frac{1}{10}$ of a gallon of the lead-paint. In other words, if these pigments have each some effect on the oil, the silica acts on twice as much oil in proportion to its weight as the white lead does. If the silica-paint is the better paint, that is an advantage; but if the white lead is the better paint, it is a loss.

It may be worthy of note that in mixing paints no changes of volume are apparent; a gallon of any pigment, or a gallon of spirit of turpentine or benzine, added to (for example) 3 gallons of oil, always produces 4 gallons.

Some years ago the late Dr. C. B. Dudley brought into general use the term "inert pigments." It was a convenient and useful expression, and is extensively used; but its meanings have always been vague, often inconsistent, and not infrequently contradictory. Dr. Dudley was chemist for the Pennsylvania Railroad, and as such had to do with paints for various uses, chiefly for cars and buildings, and gave the subject considerable study; his writings helped to a more clear understanding of many paint problems. He and those associated with him gave these matters honest, intelligent, and discriminative consideration; but, like every one else, they were influenced by their environment.

Freight-cars are usually painted with iron-oxide paints; and, whatever may be the reason, these paints are very durable on wood, although they may not prove so on iron or steel. They almost always contain a considerable amount of silica, partly free and partly as earthy silicates. It seemed evident, therefore, that silica did not destroy the durability of oil. But silica and the earthy silicates have no value as colors nor as opaque bodies, being white or nearly so in color and almost transparent when ground in oil. The opacity or hiding power of a paint depends on how much light it reflects; and a substance may be very opaque by itself, or in the air, and when mixed with oil appear transparent; this is because the oil has about the same refractive power as to light; that is, the oil itself is

transparent, and if it has the same optical qualities, or effect on light, as a pigment mixed with it, it brings the light to the fragments of solid matter, the particles of the pigment, in such a way that they enter them and pass through, instead of being reflected. Thus, uncolored glass is, as we all know, transparent; but the same glass, if finely powdered, becomes white, like snow, because the little pieces each reflect some of the light instead of letting it pass through as it would if they were flat flakes with smooth faces; now, if we could pour some melted glass on this white powder, and mix it completely, it would fill all the openings, and be like one mass of glass, and of course the light would go through it. We can not do this with melted glass, but if we have an oil that has the same qualities regarding light that glass has—and linseed-oil is something near it—we can easily wet the powdered glass with oil, and then it will be transparent, as though it were all oil or all glass. That is what we mean, practically, when we say that the oil and pigment have the same refractive power, or the same index of refraction; and that is approximately true of oil and silica, or oil and barytes, or whiting, or China clay, or gypsum, and the like. On the other hand, if we have a pigment that is what we may call an essentially opaque substance, such as charcoal or oxide of iron, we may mix it with melted glass, or oil, or anything we like, and it will make no difference with it.

But opacity or hiding power, and, what is closely related to this, color, are not the only desirable things about pigments, which are used, besides these, for three other things; first, they make the film thicker, for paint is a thicker and more viscous substance than oil, and will stick on a surface if applied in a thick layer, when as much oil would partly run off; so a paint film is thicker than a pure oil film, in fact holds more oil on the surface, and so is more durable; second, it makes a film that, when dry, is harder than an oil film, because the solid particles of pigment are harder than dried oil, and so will stand more rubbing, and wear better; third, an oil film is somewhat porous when it is dry, and the little particles of pigment get into these pores and stop them, and thus make the film more impervious to air and

water. It is plain that there is no obvious reason why a transparent pigment may not be just as good as an opaque one for all these three purposes; and if mixed with a very opaque pigment, like iron oxide, might not lessen its value in any way, if not used in so large proportion as to thin down the coloring-matter enough to make it lose its distinctive appearance; and, being cheap, would improve the paint by making it cheaper, and just as good, a quality every one is properly looking for.

Silica is a substance which is resistant, or inert, to ordinary chemical action; so are barytes, China clay, and silicates in general; and it was assumed that they were quite inactive in paint, and were called inert pigments. To this list was added gypsum, although it was well known that gypsum is somewhat soluble in water, and that it is not allowable in paint for structural metal; but it is transparent, and on this account was classed with the others; for the same reason whiting or ground chalk, which is carbonate of lime, was called inert, although it was recognized that it is alkaline and acts chemically on oil; in fact, its use in small portions was defended on the ground that it neutralized the acidity sometimes observed in linseed-oil. An accurate use of the word would certainly rule out gypsum (also called terra alba) and whiting, however it might be with the others.

The real nature of the relations existing between linseed-oil and the various pigments—or any of them—is not known. It has been assumed that white lead and zinc are “active” pigments—that they to some unknown extent combine with the oil. This is, so far as white lead is concerned, probably based on the fact that lead and oil can be combined, and are in fact combined to form driers; litharge, not white lead, is used for this purpose. It is said that linseed-oil, mixed with white lead, dries more rapidly than oil alone; to this it may be replied that linseed-oil, mixed with silica, increases in weight, in a film, by absorption of oxygen, more rapidly than oil and white lead. White lead and oil do indeed dry more rapidly than oil alone; but so little is this increase that in practice it is not recognized; as much drier is used as with many other

pigments supposed to be inactive, and it is not impossible that the gain may be due to some physical rather than chemical cause. It is frequently assumed that linseed-oil acts on all lead pigments—white lead, red lead, litharge; but not on certain salts, as the chromate. Litharge is the monoxide of lead, PbO ; oil does certainly act on this; red lead is a peroxide Pb_3O_4 which may be some compound of PbO and Pb_2O_3 , the latter being regarded as the true peroxide; and it has long been known that in practice oil and red lead will soon combine to form a solid mass. Red lead is commonly made by roasting litharge at a rather low heat in a current of air, when it takes up additional oxygen and becomes red in color. If portions of the oxide are removed from time to time it will be observed, if a microscope be used, that the red color first appears on the corners and edges of the grains of litharge, then spreads over the surface, which for a time shows its yellow color more and more faintly, until the whole of the litharge grains appear to be oxidized. These grains of litharge are unequal in size, and while the smaller ones are completely oxidized, the larger ones may still retain some PbO in the centres; and in fact analysis shows this to be the case, the proportion of unchanged protoxide sometimes amounting to 40 per cent, and often to 25 per cent. It is evident that any action which takes place between such red lead and oil may be really due to the protoxide and not to the true red lead.

Somewhat recently the National Lead Company have adopted the plan of grinding the litharge in suitable mills, dry, until the particles are broken up into an impalpable powder, before making it into red lead. The result is that nearly all these particles are completely converted throughout, and the proportion of residual monoxide is so small as, in some cases, to be almost negligible. When such a product is mixed with oil, the usual action does not occur; the mixture will stand for months unchanged, showing that it is really the litharge which is the active agent. Such red lead, though it costs more to make, is better paint material than the ordinary kind.

The product known as orange mineral, or orange lead,

is a pure red lead made by roasting dry white lead. As white lead costs more to make than litharge, orange lead costs more than ordinary red lead; but as white lead is an almost inconceivably fine powder, and as, moreover, it contains no litharge, the red lead produced in this way is of the highest attainable purity. Orange lead and oil make a permanently fluid mixture, which will keep for years without chemical action, again showing that only litharge acts on oil. And as white lead is known to be a basic compound it is not unlikely that it contains a trace of protoxide, which would allow us to believe that this compound is the only one which commonly acts on oil. In fact, under certain conditions, white lead will at ordinary temperatures turn in part into litharge. The slight action which takes place between oil and basic lead-sulphate may be explained in the same way.

In the case of white zinc we have a practically pure oxide, which has some action on oil, but this is especially marked if the oil contains, as some oil does, some free fatty acid. All natural oil contains a little, and some refined oils contain 8 or 9 per cent, while others are practically free of acid. Even when mixed with neutral oil white zinc behaves in a remarkable way, as will be explained later. As has been said, a common proportion of white lead and oil is 1 part of pigment to 3 of oil, by volume, making a paint which weighs nearly 20 lbs. to the gallon; but the standard zinc paint weighs 14 lbs. to the gallon. To deduce the proportions of zinc and oil when we know the weight of the paint we may proceed as follows:

The paint = 14. lbs. per gal.
 Linseed-oil = 7.7 " " "
 ZnO = 45. " " "

Let x = lbs. oil in 1 gal. paint
 $14 - x$ = lbs. ZnO in 1 gal. paint

$\frac{14 - x}{45}$ = Fraction of a gal. of ZnO

$\frac{x}{7.7}$ = Fraction of a gal. of oil

$\frac{14 - x}{45} + \frac{x}{7.7} = 1$ gal.

Least common denominator is 346.5

$$\frac{107.8 - 7.7x}{1} + \frac{45x}{1} = 346.5$$

$$107.8 + 37.3x = 346.5$$

$$\frac{107.8}{37.3} = \frac{346.5 - 107.8}{37.3}$$

$$2.917 = \frac{238.7}{37.3}$$

$$2.917 \times 37.3 = 108.8 = x$$

$$14 - 6.4 = 7.6 = 14 - x$$

The above figures are given as an illustration. Zinc in oil is sometimes made up to weigh 15 lbs., but this is rather heavy to brush well; and the weights per gallon on both oil and ZnO are approximate. It will be noted, however, that these figures, which are not much out of the way, call for $\frac{5}{6}$ gal. oil to $\frac{1}{6}$ gal. ZnO, as compared with $\frac{3}{4}$ gal. oil to $\frac{1}{4}$ gal. white lead; and the white lead is the more fluid paint, although the oil is three to one instead of five to one.

This brings us fairly to the subject of the fluidity, or better the viscosity, of paints. Various forms of apparatus have been used to determine the viscosity of liquids, but paint is a rather imperfect liquid, and so far as the writer's knowledge goes, the Stormer viscosimeter is the most satisfactory instrument to use with paint. This consists of a flat-bottomed cylindrical cup $1\frac{7}{8}$ in. internal diameter by $2\frac{1}{2}$ in. deep, having two radial vertical wings or septa $\frac{1}{2}$ in. wide attached to its inner wall, and extending from the bottom to within $\frac{5}{8}$ in. of the top, being in fact obstructions to the rotary flow of the liquid. Within this cup is suspended a stirrer, the revolution of which is resisted by the viscosity of the liquid; this stirrer is a hollow metal cylinder $1\frac{3}{8}$ in. long and $1\frac{1}{4}$ in. diameter, its lower end open, the upper end closed except that it contains four holes, each $\frac{3}{16}$ in. diameter, symmetrically arranged. This cylinder is supported from above by a vertical rod or shaft, concentric with the cylinder, but external to it, being $\frac{3}{16}$ in. diameter by $2\frac{1}{4}$ in. long. The end of this is attached by a collar and screw to the bottom of a vertical shaft which carries a pinion $\frac{1}{2}$ in. diameter having 25 teeth, which in turn is driven by a gear $5\frac{1}{4}$ in. diameter with 275 teeth, to which large gear is attached a drum $1\frac{1}{2}$ in. diameter around which is wound a small silk cord, the external part of which

passes over a small pulley and is attached to a driving-weight. The top of the shaft carrying the small gear carries also a screw or worm which engages and drives the serrated edge of a graduated disk or dial, one revolution of which marks 100 revolutions of the stirrer. The stirrer is so suspended that its bottom is $\frac{3}{8}$ in. above the bottom of the cup, and in consequence its top is $\frac{3}{4}$ in. below the top of the same; when in use the cup is filled to within $\frac{3}{8}$ in. of its top with paint or other liquid which therefore stands $\frac{3}{8}$ in. above the top of the stirrer. To make a hundred revolutions of the stirrer the weight descends about 39 in. The stirrer comes within $\frac{1}{16}$ in. of each of the radial wings, one on each side of the cup, already mentioned.

The index of viscosity may be defined as the force required to produce a given shear in a given time; if we adopt a minute as the unit of time, and the shear produced by 100 revolutions of the stirrer as the unit shear, then the viscosity will be the number of grammes (or units of weight) required to cause the stirrer to revolve 100 times in 1 minute. It is convenient to have some standard liquid to refer to; with thin liquids water is usually taken; with paint 95 per cent glycerine, the viscosity of which is suitable for paint, is very convenient. With the instrument which the writer uses this requires about 230 grammes. It is necessary to keep the instrument clean, and oiled with a little thin lubricating oil; also to make allowance for the friction of the machine, which should be a constant quantity, and in the instrument referred to is about 5 grammes. The instrument has a friction-brake, which being opened allows it to start; it is used with a stop-watch. As at present sold it is not provided with a suitable scale-pan and weights, but is to be used with a fixed weight, which is sufficient if we wish only to bring various mixtures to one standard, hence it is like using a fixed measure instead of a scale. It is very important to use it at a standard temperature.

With such an instrument it is possible to define the viscosity of paints. No doubt the degree of fineness of the pigment will be found to have some effect, and very likely the amount of driers used will make differences. So far as

the writer's experiments have gone (they have only begun) only mixtures of pigments with raw oil have been used, except that some proprietary paints have been examined. 20° C. has so far been used as the standard temperature, and 100 revolutions per minute. Some of the results are as follows:

Raw linseed-oil	20.6 grammes
Boiled linseed-oil	37 "
Dutch process white lead, gal. weighs 20 lbs.	127 "
White zinc, gal. weighs 15 lbs., freshly made	255 "
Same sample, after 30 days	187 "
Another sample white zinc, 24 days old	175 "
Same sample as last, 52 days old	161 "
Sublimed lead sulphate, gal. weighs 19 lbs.	160 "

The very remarkable fact shown above is that zinc-and-oil becomes more fluid by standing; and this is true even if the paint is made from paste zinc-and-oil, which paste had been aged (paste of 2 gal. raw oil to 100 lbs. white zinc).

For purposes of comparison a collection was made of "outside white" paints, *i.e.*, white paints made for painting the exterior of houses, by various makers, as follows:

Patterson-Sargent's	100
Masury's	165
Sherwin-Williams'	170
Patton's sun-proof	185
Lowe Bros.'	210
Devoe & Reynolds' Lead and Zinc	227
Heath & Milligan's	234
Harrison Bros.'	257
Benj. Moore's	322
Lucas'	400

Other tests made with paints mixed in the proportion of 1 part by volume of pigment to 3 of raw oil, showed that they stood as follows (each higher in viscosity than the preceding): Terra alba, barytes, whiting, silica, white lead, white zinc, asbestine, China clay.

It should be added that by correspondence it was learned that some of the proprietary paints were intentionally made high in viscosity, with the expectation that the user would thin them with oil or turpentine before using.

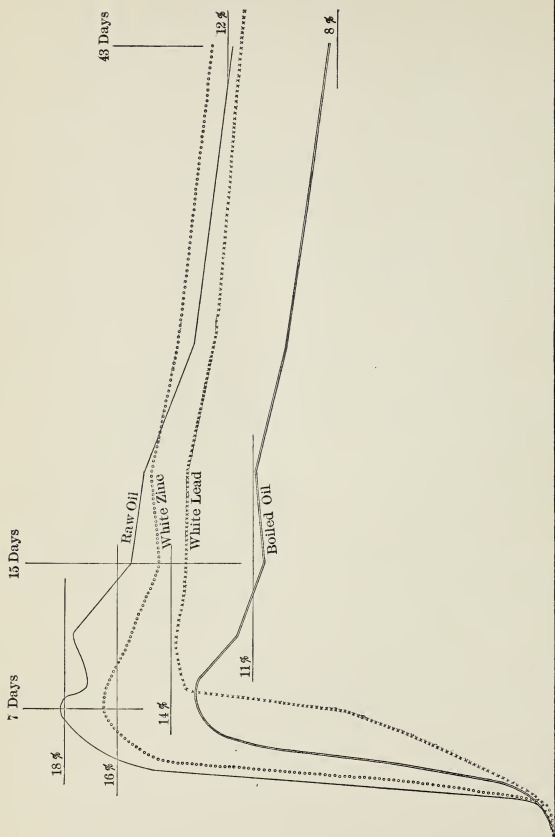

FIG. 39.—Drying-curves of Thin Films.

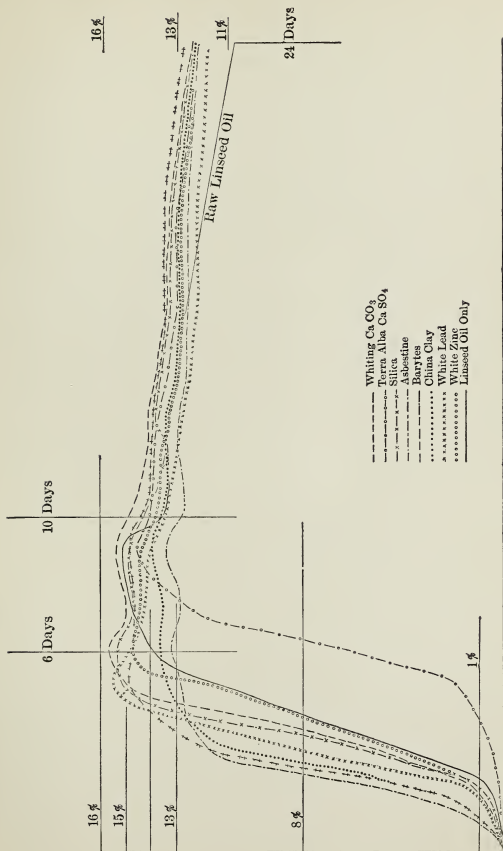

FIG. 40.—Drying-curves of Thin Films.

It does not appear that fineness has anything to do with viscosity since white lead and white zinc are much finer than terra alba or barytes, which are less viscous, and also they are finer than asbestine or China clay which are more viscous. It seems reasonable to suppose that if different pigments have different surface-attraction for oil, this quality might affect their viscosity; also, probably, their value as paint material. The fact that white zinc-and-oil loses viscosity to a considerable extent on standing is beyond question; not only is it measurable with the viscosimeter, but it is easily noticeable on brushing it out. The fact, also peculiar, that, when ground to a paste with a small quantity of oil and stored for a time in that condition, and afterward thinned with more oil, it still shows this property, may indicate that there is some component of the oil, existing in small amount, which is acted on by the zinc; which latter, being present in excess, is able to act on every fresh portion of oil which is added to it. White lead does not show this peculiarity, and the writer is not certain that any other pigment than zinc has it.

The reader is now asked to recollect what has been said about the drying of linseed-oil, its gain and subsequent loss of weight, and the manner of carrying on the tests with glass plates. Besides testing raw and boiled oil, experiments of this sort were made with paints composed of 1 part by volume of raw oil (without drier) and 3 parts by volume of each of the following pigments: white lead, white zinc, whiting (calcium carbonate), gypsum (terra alba), silica, asbestine, barytes, and China clay; with results shown in the accompanying diagram, which, however, records only the first twenty-four days. It may be added that after this all these curves very slowly approached the base line, until after eight months (at the time of writing) they are from $1\frac{1}{2}$ to $3\frac{1}{2}$ per cent above it. No doubt the fact that these films are four to six times as thick as the films of unmixed oil already described, which results from the other fact that they are five to ten times more viscous, accounts for the fact that they have not as yet lost all their initial gain; the atmospheric oxygen not so readily reaching the lower layers of the thick films. The white

zinc-paint has at present lost considerable less than any of the others.

These drying-tests were carried on at ordinary room temperatures, in strong diffused light, near a window of clouded glass; but after some months the plates were removed to a comparatively dark apparatus case having glass front; there, as was to be expected, the oil, which before was colorless, became yellow. The white-lead paint showed this first; next came the barytes; then after a long interval, all the others except the zinc, which now indeed shows it, but in a less degree. Of course the barytes is an almost transparent pigment, and the yellowing is probably due entirely to the oil. It is well known that the oil in paint bleaches in the sunlight and turns yellow again in the shade, and that white-lead paint shows this much more than white zinc; but that it should appear in a barytes paint more than with other equally transparent pigments is remarkable, to say the least.

Inspection of these drying or oxidation curves shows that we must probably concede the fact that these pigments in some way act on the oil. The asbestine, barytes, and China clay either promoted early oxidation or retarded peroxidation, more than white lead; the white-zinc curve almost coincides with that of unmixed oil; and the gypsum paint was fluid for some time after all the others were tolerably firm to the touch. These things cannot be accidental. The films were nearly the same in thickness; they were similarly prepared, and put on the same day; they were in the same drying-case, and had the same amount of light and air; the oil was absolutely the same.

Still another set of phenomena was observed. These paint samples, which were ground in the laboratory, were preserved in well-filled, well-stoppered glass bottles. After standing three months it was observed that in all cases the pigment had settled somewhat, leaving part of the oil clear, on top. With white lead, whiting, and gypsum the color of the oil, which was unbleached raw oil, was unchanged. With white zinc and silica the oil was bleached, being paler than oil refined with sulphuric acid. With asbestine it was very pale (yellow), equal to a fine fuller's-earth bleached

oil; the same with China clay, except that the color of the oil was pale green; and barytes gave a green oil, nearly as pale as the last. The analytical data (constants) of these oils have not been determined; but taken in connection with the drying curves and the viscosity, we must agree that the idea that any of these pigments is inert to oil is no longer to be entertained. This does not mean that they are therefore without value; on the contrary, nearly all the pigments which are of undisputed value have long been known to act on the oil. It cannot be too clearly understood that the value of any pigment is a matter of experimental, empirical knowledge, and that we do not yet know paint phenomena well enough to make predictions of much value. It will not do to say, for example, that such and such pigments are inert to oil, therefore we will add certain quantities of them to secure certain results. They are not inert, and we will not get those results, or if we do they are caused by something we know nothing about. I am myself perfectly certain that my own knowledge of mixtures of the best-known two pigments, white zinc and white lead, is less than I thought it was five years ago.

This is because my knowledge of white zinc has increased a little; I know some more about white lead, and perhaps a little more about linseed-oil than I did five years ago. Something has been said of linseed-oil, and some more will be found in the analytical data; it may be very well to say a little about white lead.

White lead is a white pigment consisting of carbonate and hydrate of lead, whose formula is commonly given as $2\text{PbCO}_3\text{Pb}(\text{OH})_2$, which corresponds to 68.91 per cent PbCO_3 and 31.09 per cent $\text{Pb}(\text{OH})_2$; or it contains 80.12 per cent of metallic lead. Considerable discussion has taken place among chemists as to whether this is the true theoretical formula; but in practice this is apparently about right. If the process of forming carbonate is allowed to go on, more carbonate is formed; and even with the most careful washing traces of metallic lead sometimes are found in the finished product; moreover, it retains traces of acetate of lead with great obstinacy; and in one way or another it is found that small variations in composition occur;

so that, unlike some crystallized products, the precise formula is difficult to settle to the satisfaction of theorists. But the formula given is probably correct, corresponds as well as should be expected to the analyses, and is in fact generally accepted.

The most common way of preparing it in the United States is by what is known as the Dutch process. The lead, which is in all white-lead manufacture required to be of exceptional purity, especially free from silver and copper, is cast in round flat perforated plates, about 5 inches across and $\frac{3}{16}$ of an inch thick, weighing about a pound each, and technically called "buckles." These are put in earthen corroding pots, 10 inches high and 6 inches in diameter, the lower 3 inches being smaller than the cylindrical upper part (so the buckles will not enter), and this lower part is glazed within, to hold the weak acetic acid used. About half a pint of 2½-per-cent acid is put in each pot, and then the upper part is completely filled with buckles which lie horizontally, one on another. Only cast lead is used; if the buckles were stamped out of sheet lead the metal would be too compact and would not corrode well.

The building where the corroding is done is called a stack building, and is divided into rooms, or stacks (so-called because the pots are stacked one on another), which stack-rooms are of various sizes, frequently about 20 by 40 ft. in area, and about 30 ft. high. At first a layer of tan-bark about 20 inches deep is placed on the floor; then on this a layer of corroding pots, which are then charged with acid and buckles, except a margin of about 15 inches around the edge of the surface, which is packed with tan-bark, and known as the "banking." Boards are laid on top of these pots, and on this false floor another layer of tan-bark about 15 inches thick, then a layer of pots as before which are charged with acid and lead buckles, and then another layer of boards, and so on until the stack is completed, containing ten or twelve layers. Some means are taken to ventilate the different layers, the most common being a wooden flue running from each tier up near the centre of the stack to the top, where it may be opened more or less as may be desired.

The tan-bark undergoes a slow combustion, apparently a fermentation, but no micro-organisms have been detected, although carefully sought. At all events, the temperature rises, sometimes to 160° or 180° F., and carbonic acid is given off abundantly. In presence of the acetic acid vapors and carbonic acid the metallic lead is converted first into basic acetate of lead and then into basic carbonate, which is the pigment. This takes from 90 to 120 days. Then the tan-bark is removed and used again to build another stack, while the pots are emptied of their contents, which consists of white lead and some uncorroded metal.

Machinery is used for mechanically separating these, and the white lead is finally ground in water in burr-stone mills, after which it is floated to separate any heavy particles, such as metallic lead, and finally allowed to settle in settling-tubs. From these it may be pumped into great copper steam-jacketed drying-pans, or it may while still wet be mixed, in suitable mechanical mixers, with oil, which has a greater attraction for white lead than water has and will displace it, leaving less than a $\frac{1}{2}$ per cent of water in it; such lead is preferred by many as being softer than that which has been dried by heat.

White lead is also made in three large factories by the Carter process; in which the melted lead is allowed to trickle into a jet of superheated steam, by which it is "atomized" into small spherical particles. In this condition it is put into large horizontal wooden cylinders, which may be made to revolve and thus agitate the contents. Dilute acetic acid and water are from time to time sprayed into these cylinders, and carbonic acid, obtained by burning very pure coke, and purified, is caused to pass through them; in about twelve days the lead is nearly all converted into white lead, which is then washed, floated, and otherwise treated as already described.

Another very similar process, known as the Rowley or "mild" process, is in practical use; in this the lead is sprayed or "atomized" into very fine particles, the aim being to make it as fine as possible, so that it will mix with matter to form a pulp or mud, which is a condition avoided in the Carter process. This is put into revolving drums, wet,

and air blown through; no acetic acid being used. The lead oxidizes under these conditions, yellow hydroxides being formed; these are carbonated by finally blowing carbonic acid through the agitators. In this way white lead is the product obtained.

Still another way of making white lead is by a precipitation process; the metallic lead is treated with dilute acetic acid in large wooden tanks, forming basic acetate, which is then treated with carbonic acid gas, until a basic carbonate is formed. This is known as the Matheson process, a modification (as to details) of the old French, or Thenard process, which is said to have gone out of use in France, but has been improved and made practicable here.

As to the merits of these different processes it is impossible to speak with precision. All make merchantable white lead, and each has some advantages of its own. It is largely an economic question; and so far the old Dutch or stack process holds its own; the National Lead Co. recently built a very large and fine new factory to operate under this process, which they would hardly have done unless they thought it on the whole the most generally satisfactory. It is generally believed that this process produces white lead which requires less oil and has greater opacity or hiding power than any other. The Carter lead, on the other hand, is whiter and finer. But all white lead has good opacity, working quality, and whiteness, and as for fineness the talk about that is mostly talk; all white lead is very fine; only a few other pigments are as fine. Personally, I suppose the best quality of lampblack is the finest pigment there is; next, I am disposed to believe, comes Fireman's precipitated magnetic oxide of iron; then come, in a group, white zinc, sublimed lead sulphate and Prussian blue; then the various white leads; and "after these the deluge." No doubt some of the iron oxides are comparable in fineness with white lead, but others of about the same colors are relatively coarse; and while it may be possible to grind pigments made of solid rock to any desired degree of fineness, it is commercially unprofitable to grind them enough to compare with white lead, which is a chemical precipitate, as are all those which precede it in the above list.

The only means known to the writer for differentiating and studying these very fine pigments is by G. W. Thompson's "classifier," a description of which, from the *Proc. of the Am. Soc. for Testing Materials*, vol. x., 1910, is here given by Mr. Thompson.

The classification of coarse materials according to size is very readily accomplished by means of screens. There are, however, many fine materials—pigments, cements, etc.—a large proportion of which will pass through the finest screens obtainable. Fig. 43 shows photomicrographs of No. 100 and No. 200 wire screens such as are used for cements, and of No. 21 silk bolting-cloth, all of which are magnified approximately forty diameters. (All the photomicrographs shown in this paper have this same magnification.) It will be observed that the openings in the silk bolting-cloth are smaller than those in the No. 200 wire cloth. Most pigments contain but a very small portion which will be retained on No. 21 silk cloth, and yet they vary considerably in degree of fineness—that is, in the proportion of relatively coarse and relatively fine particles. This is evidenced by the touch, by variations in tinting and oil-taking power, and by the voids in the dry pigments when subjected to uniform pressure, etc.

Students of paint problems especially have for a long time recognized the desirability of measuring the degree of fineness of pigments. There is no good definition at present covering fineness, and it would appear that much work must be done before this definition can be drawn up. The most important work in this direction is to classify the particles of a pigment, as far as practicable, into groups according to their size. We have constructed an apparatus (to be described later) which does this practically and effectively. This does not mean that the apparatus is not subject to limitations, and that improvements cannot be made in the direction of making it more accurate and more useful for the purpose for which it was designed.

It is well known that homogeneous substances fall in liquids with a speed that varies with their size—that is to say, the larger particles fall more rapidly than the smaller ones; and if a stream of liquid can be given a definite up-

ward flow, certain relatively coarse particles will settle out and other relatively fine particles will be floated away. Laboratory classifiers following this principle have been made for the classification of fine particles, but usually they have been built with the idea of making only two classifications. What we have attempted to do is to make five classifications with our apparatus in one operation.

Bodies fall with the same speed in a vacuum, without regard to their size or specific gravity. In fluids the fall is affected by the specific gravity of the substance and the surface it exposes. The greater the surface the greater the friction which retards the fall, and as small particles present larger surfaces in proportion to their weights than do large particles, large particles fall more rapidly. The surface decreases as the square, while the weight decreases as the cube of the diameter of the particles as they become smaller. It is probable that with a classifier working on spheres or cubes, very exact results could be obtained; but as particles vary from the spherical or cubical shape, the surface becomes greater and introduces other factors. This is one of the limitations of classification apparatus of this kind which must be fully recognized. But it appears probable that in the case of homogeneous substances the particles will vary regularly in surface according to their size, even if they are irregular in shape; that is to say, the very fine particles will be irregular equally, or approximately so, with the coarser particles and practical results will be obtained in their classification.

In a classifier depending upon the vertical flow of fluids, the velocity of flow corresponds (according to Callon's formulas, which are based on Stoke's studies) with particles of a certain size, specific gravity, and shape; that is, at a given velocity such particles will just stay in suspension, and particles slightly larger, heavier, or with less surface, will sink.

There are other factors, however, than the size, shape, and specific gravity of the particles which determine what this flow should be. They are the specific gravity of the fluid and the specific surface relation which this fluid bears to the particles in question. If we include in one general

constant, C , the specific gravity of the liquid and the specific surface relation referred to, we can construct the following formula, which will give the velocity at which a given fluid should rise in order that particles of a certain size may just be kept in suspension.

Let v = the velocity, C = the constant referred to, D = the specific gravity of the particle, d = the specific gravity of the fluid, and a = the linear dimension of the particle or its mean diameter.

Then:

$$v = C \sqrt{a(D - d)}$$

From this it is seen that the mean diameter of the particle is proportional to the square of the velocity; that is, if we double the velocity we quadruple the diameter of the particles left behind, etc.

The apparatus which we have designed is shown in detail in Fig. 41. It consists of four brass cones placed one above the other, arranged so that the overflow from the top cone, passing through a funnel, discharges into the bottom of the second cone, and the overflow from the second cone passes through a funnel into the bottom of the third cone, and so on.

The apparatus is arranged so that the liquid used can work at a constant head, which is indicated by a gauge. We have found it most satisfactory for the purposes for which we have used this apparatus to use kerosene as the floating medium. This selection was made on account of the high wetting-power of kerosene and its low viscosity. The apparatus was constructed at the start by guesswork, and we made our first cone with a base diameter of 75 mm., and as that apparatus was constructed we found that working under a 10-c.cm. head we got a vertical flow of 5 c.cm. in the top cone. The second cone was made to have a base area twice that of the first cone, the third cone to have twice that of the second, and the fourth cone to have twice that of the third; so that the fourth cone has one-eighth the speed of flow that the first cone has. Then, theoretically, the smallest particles caught in the fourth cone should have $\frac{1}{8}$ of the diameter of the smallest

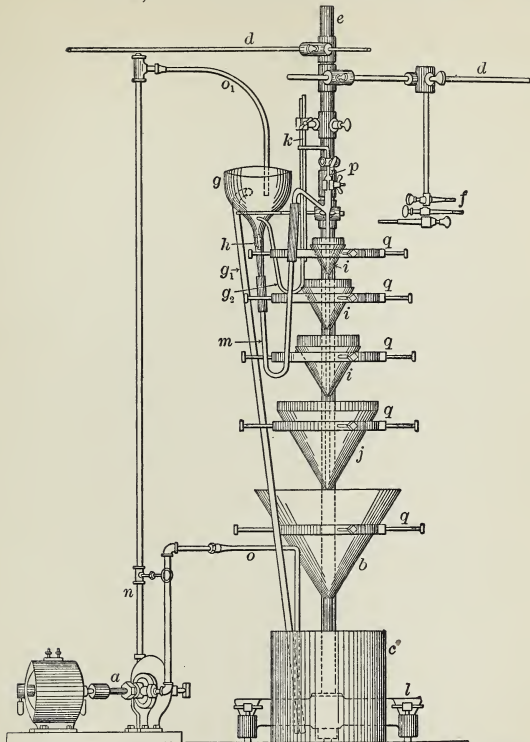

FIG. 41.—Thompson's Classifier, for Pigments and Fine Particles in General.

a, Centrifugal pump directly connected with a $\frac{1}{8}$ -h.p. electric motor; *b*, 13-in. ribbed glass funnel; *c*, 5-gallon glass aquarium jar; *d*, steadying rods fastened to wall, 10 mm. diameter; *e*, general supporting rod, 1.6 metres long, 30 mm. diameter; *f*, ring supports for funnels, used when cones are being cleaned; *g*, special glass funnel with overflow; *g*₁, glass tube to aquarium jar; *g*₂, rubber connection to gauge; *h*, regulating tube, 50 mm. long, 2.5 mm. diameter, fitted in neck of funnel through cork; *i*, cones set in funnels, supported on three lead wires, 1 mm. diameter, to allow for overflow from cone; *j*, cone No. 4, without glass funnel; *k*, millimetre gauge showing head; *l*, special tripod base; *m*, $\frac{1}{2}$ -in. block-tin piping connected by rubber tubing; *n*, $\frac{1}{2}$ -in. brass piping with gate-valve, connections, etc., from pump; *o*, $\frac{1}{2}$ -in. block-tin piping from reservoir connecting with brass pipe; *o*₁, $\frac{1}{2}$ -in. block-tin pipe; *p*, special glass tee with stopcock, for starting flow; *q*, cast-iron rings with three threaded pointed bolts—supports for funnels and cones.

particles caught in the first cone, which holds good through the series. This, of course, is based on the supposition that the particles are spherical or cubical. We have no means of determining what this relation would be with particles varying appreciably from the sphere or cube.

The diameters of the four cones as finally decided upon were:

First cone.....	75 millimetres
Second cone.....	106 "
Third cone.....	150 "
Fourth cone.....	212 "

Some trouble was experienced in our early experiments in controlling the flow. We used various devices, and found that the best method of control was by means of a small glass tube about 2.5 mm. bore and 50 mm. long.

The flow of liquids through tubes is based on the formula of falling bodies, the velocity of flow being proportional to the square root of the height or head, except in so far as there is a loss by friction. The simplest way of expressing this formula is:

$$v = C_1 \sqrt{h - h_1}$$

where v = the velocity, h = the head, h_1 = the loss of head due to friction, and C_1 = a constant including the size of tubing through which the flow takes place, gravity, etc. We can calculate C_1 algebraically by assuming that at any two points high in the rate of flow, C_1 and h_1 remain constant. Having done this we can calculate the variation in h_1 . Ordinarily we find that above 5 c.cm., h_1 is constant; that is, the loss in head due to friction is uniform above a certain head.

After setting up the apparatus, levelling all its parts, and making sure that all the parts are vertically above one another, in so far as is necessary, a flow curve similar to that shown in Fig. 42 is constructed, giving the flow in cubic centimetres for heads from 1 to 10 cm. If, therefore, it is desired at any time to make a classification-test operating at a different flow, this flow and the necessary head at which to work can be obtained from the flow sheet, or calculated from the equations obtained.

The apparatus was originally designed for lead pigments, especially white lead, and we have found that the classification working with a 5-c.cm. upward flow in the first cone gave most satisfactory results, and we have usually worked on 10 grammes of material. In order to obtain satisfactory results we believe that the amount of material used should vary directly with the specific gravity, and that if with white lead 10 grammes are taken, then for a material having

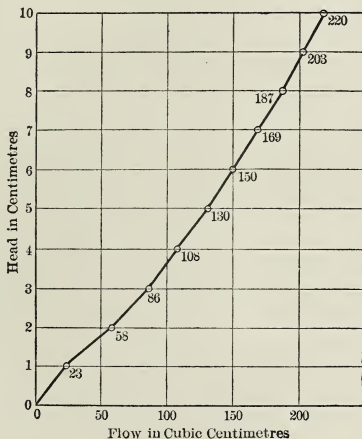

FIG. 42.

a specific gravity half that of white lead, 5 grammes should be taken. Furthermore, the flow should vary with the specific gravity according to the formula given above and which we repeat here:

$$v = C \sqrt{a(D-d)}$$

or if we make C_2 to include C and \sqrt{a} ,

$$v = C_2 \sqrt{D-d}$$

Consequently, assuming that d is the same for all materials.

as D , the specific gravity of the material, increases, the velocity, v , also should increase.

It is more convenient to consider the velocity in cubic centimetres of flow, and we have standardized our apparatus to run 220 c.cm. per minute at a head of cm. (for a 5-c.cm. vertical flow this would really be 220.85 c.cm.).

Assuming for the time being that

$$\begin{aligned}v &= 220 \\D &= 6.60 \\d &= 0.83\end{aligned}$$

then C_2 in the above equation would be approximately 94, and with any new material having a specific gravity of D_1 , the formula would be:

$$v = 94\sqrt{D_1 - 0.83}.$$

If we were classifying a sample of barytes and found its specific gravity to be 4.3, the amount taken would be 6.5 grammes and the flow would be:

$$v = 94 \sqrt{4.3 - 0.8} = 176.$$

The velocity 176 c.cm. per minute is only approximately reached by this method and it may be necessary to vary the head of a millimeter or so to get the flow exact.

TABLE I—CLASSIFICATION TESTS

All Values are Percentages

Retained on	White Lead.	Red Lead.	Cement.		Barytes.		Ochre.
			No. 1.	No. 2.	No. 1.	No. 2.	
No. 21 silk cloth	trace	trace	33.33	33.32	0.33	0.23	1.42
First cone	3.42	1.31	25.53	26.06	33.51	34.48	5.09
Second cone	6.41	9.99	7.17	8.17	17.32	17.50	7.72
Third cone	6.61	14.98	8.05	6.29	16.16	17.69	10.79
Fourth cone	8.72	28.70	6.82	7.37	9.69	9.15	12.95
Remainder	74.84	45.02	19.10	18.79	22.99	20.95	62.03

Table I gives the results obtained by the classification of four separate materials: white lead, red lead, Portland cement, and barytes. We have no serious difficulty in obtaining concordant results on white lead, red lead, and barytes. We have not done enough work on cements to

be sure that the apparatus is applicable to them. It is our custom first to put the materials to be classified through No. 21 silk bolting-cloth, and then to classify the particles that pass through this cloth.

Figs. 44 to 47, inclusive, are photomicrographs of classified particles of white lead, red lead, Portland cement, and barytes.

Fig. 8 shows a battery of three classifiers and an arrangement whereby two classifications are made, using the first cone only.

It must not be assumed that the use of this classifier is simple and free from difficulties. It is probable that with every particular material which it is desired to classify, some special floating medium could advantageously and preferably be used. We have used kerosene because it seemed most available for our purposes. We notice, however, even with kerosene, that temperature affects the flow; that is, an apparatus standardized to deliver 220 c.cm. at a 10-cm. head at 60° F., will deliver a larger amount at 80° F., the internal friction of the kerosene being less at the higher temperature and the kerosene also having expanded somewhat. It is probable, however, that this higher flow is accompanied by a lessened floating effect, so that the result will not be affected to the extent that the increase in flow would indicate. There is also at times a tendency of particles to flocculate which we have not entirely been able to avoid. This will, of course, cause fictitious results.

This classifier is operated as follows: The amount of the material to be treated is diffused in kerosene so that the particles are completely separated and transferred into the first cone. The glass tube is then lowered into the cone until it nearly touches the apex. The current of kerosene is then started, the level noted on the gauge, and the air sucked out of the upper part of the glass T-tube. Ordinarily this is all one has to do until the classification is complete, which requires two hours. Sometimes the material to be classified settles in the first cone, in which case a slight tapping of the T-tube will start it in motion. When the classification is complete the kerosene is allowed

to settle and is decanted. The sediment in each case is washed into clock glasses with kerosene, allowed to settle, decanted, and washed two or three times with ether. It is then dried and weighed.

It appears by using this apparatus that three-fourths or more of Dutch process white lead is so fine that it is practically of immeasurable fineness. The various estimates which have been from time to time published of the "average fineness" of pigments are the merest guesses of amateur microscopists, and are not of the slightest value. It is possible to measure, with a microscope, the largest particles of lead in cones 1, 2, and 3; but a few of the largest in cone 4 obviously belong in 3, a few in 2 belong in 1, and probably a few of the finest in 1 belong in 2; and to get a true average of sizes in 1, 2, or 3, while it may be possible would be a work of great difficulty; it is doubtful if it could possibly be done with cone 4; and as to the residue comprising portion 5, which makes up the greater part of the pigment, it is not merely hopeless, it is as absolutely impossible as it is to "average" the apparent size of the stars in the sky, where each increasing telescopic power reveals new infinities of star-dust. The more one uses the microscope on these really fine pigments the stronger becomes the impression that what one appears to see consists of agglomerations of excessively and immeasurably fine particles, which loosely adhere in irregular masses; and microphotographs show these as if they were definite particles of appreciable size. The really definite, hard, smooth particles in the coarse grades are easily seen and examined; but the very largest of these are only one or two thousandths of an inch in diameter, and these are so few that they form a very small percentage of the whole.

In the coarser pigments there is always some immeasurably fine portion, but the relatively coarse portions increase in percentage, and in fact form the greater part of the whole.

A microscope is an interesting and useful instrument; but the person who uses it is sometimes neither interesting nor useful, and microphotographs may be made and interpreted in all sorts of ways. One of my acquaintances,

who is a steel expert, long carried about a microphotograph of a steel section, and also a photograph, slightly reduced in scale to make it of the same diameter as the other, of one of the small cakes known as "ginger-snaps," and no

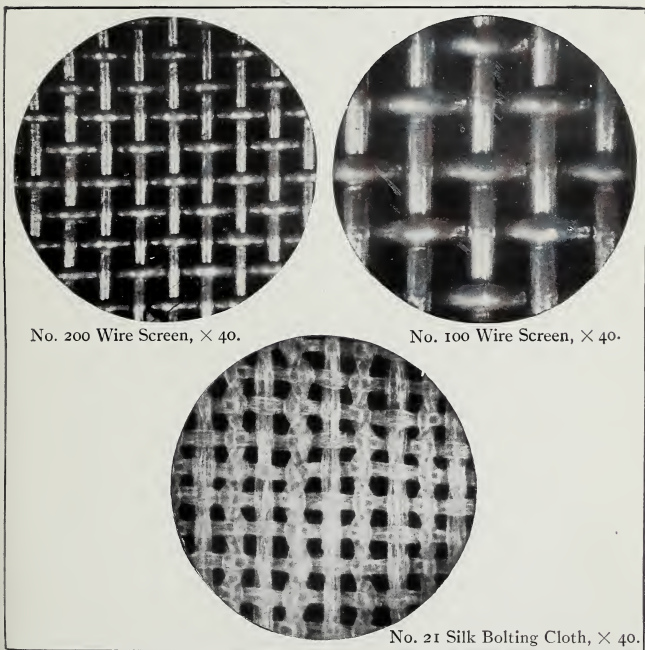

FIG. 43.

one could tell which was which. From time to time the technical papers print pictures of microphotographs of painted surfaces, most or all of which might have been made from the surfaces or "frosting" on cakes; they are not

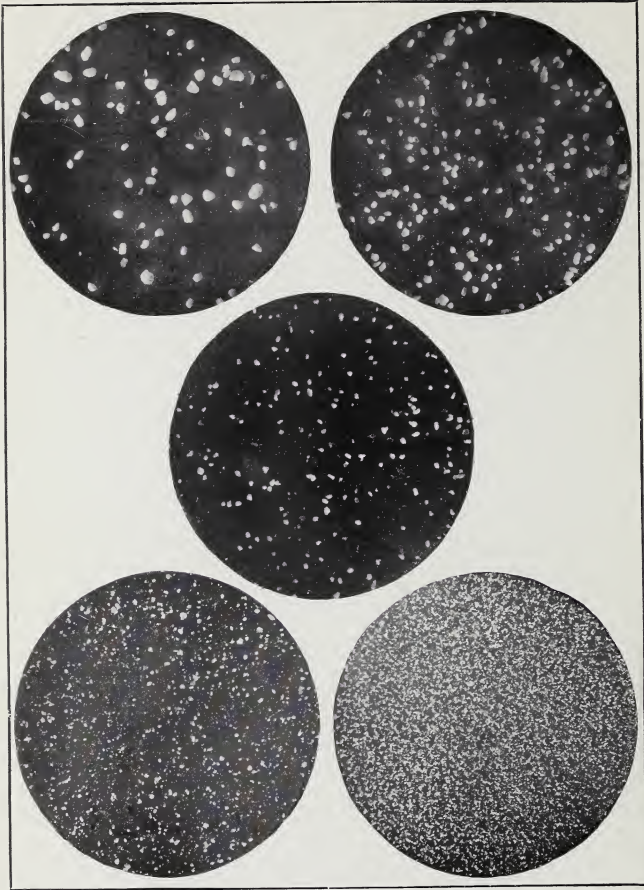
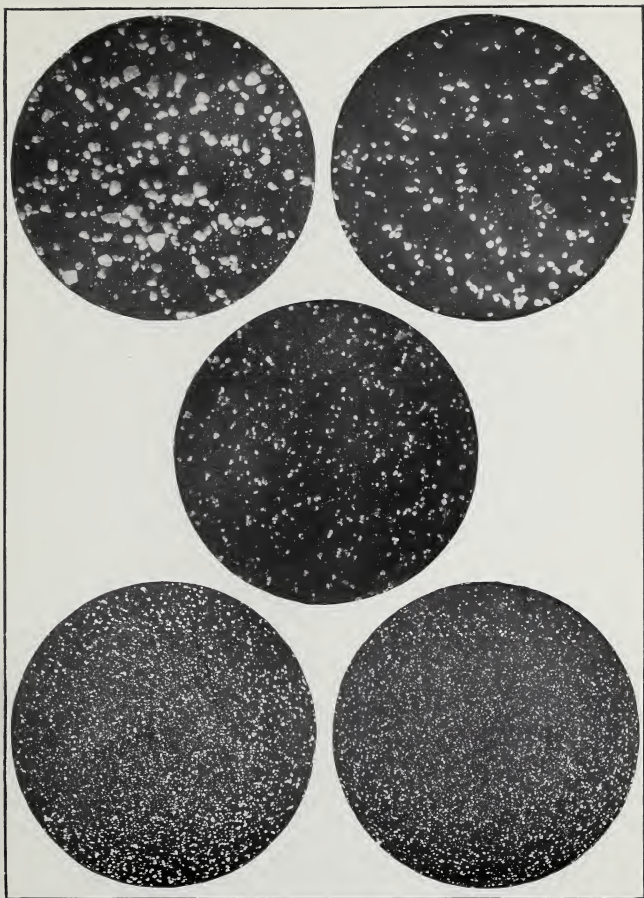

FIG. 44.—White Lead, $\times 40$.

FIG. 45.—Red Lead, $\times 40$.

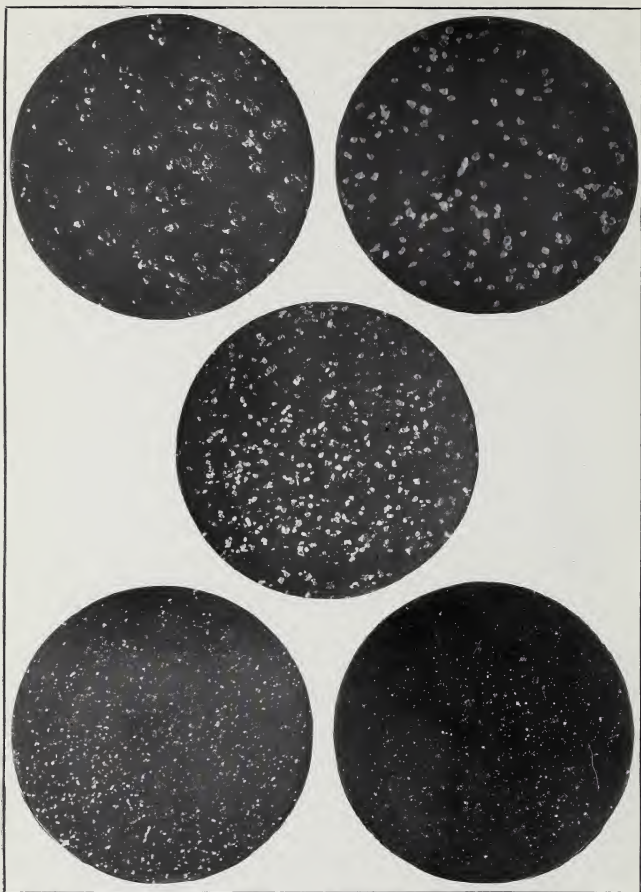
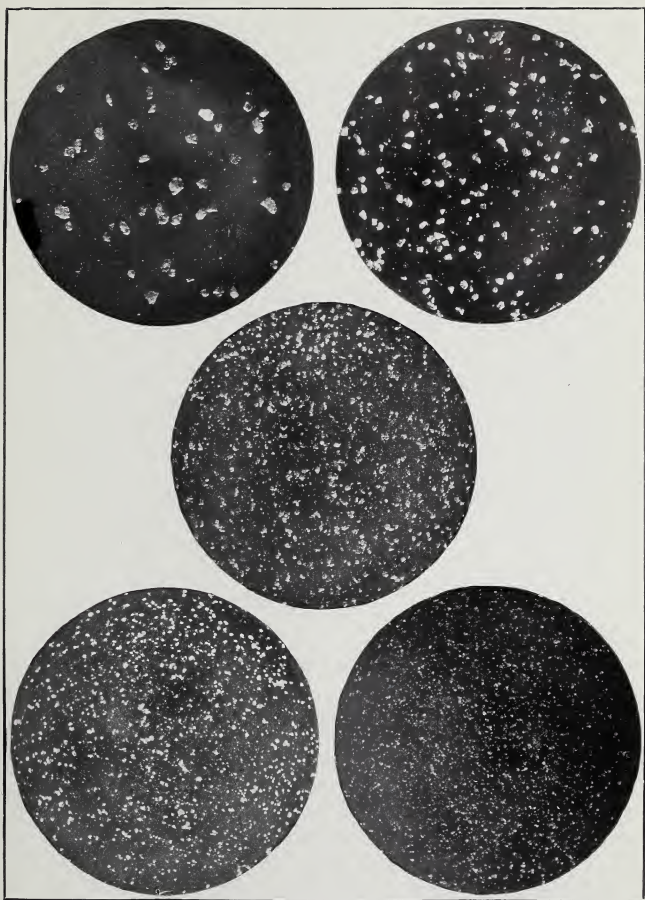

FIG. 46.—Barytes, $\times 40$.

FIG. 47.—Cement, $\times 40$.

made in that way, but they would be just as valuable if they had been.

When we say that one white lead is finer than another, we mean that it has a noticeably smaller percentage of the particles of appreciable size. We do not say this of different grades of white zinc, as probably this pigment does not contain such particles except as accidental impurities; but for most purposes, a small percentage of these relatively coarse particles, which still are for the most part less than a thousandth of an inch in diameter, makes no difference. The real reason why zinc differs from lead is not so much its fineness as that it is, in the best qualities, a little more purely white, and it bears somewhat different relations to oil and especially to oleoresinous varnish. It is well known that white-zinc paint lacks the opacity or hiding power of white-lead paint; but this does not mean that white zinc is less opaque than white lead. It is generally estimated that a coating of zinc-paint is $\frac{2}{3}$ to $\frac{2}{5}$ as opaque as one of lead; but in fact a gallon of zinc-paint has from $\frac{3}{5}$ to $\frac{2}{3}$ as much dry pigment, estimated by volume, as a gallon of lead-paint has, so that in actual opacity of the two pigments there is not much choice. It has already been pointed out that in the viscosimeter tests the zinc-paint is much more viscous than oil, and this is one reason why more oil has to be used in making a zinc-paint, and it is on that account more transparent, as the oil itself is so.

We frequently hear it said that the oil is the life of the paint. If this were true, oil alone should be more durable than paint, which is far from being the fact. The value and use of pigment has been already explained; but too much pigment, like too much oil, is objectionable; and while roughly speaking 1 part by volume of pigment to 3 of oil is an approximation to what makes a workable paint, pigments differ from such a standard, and zinc somewhat widely. If we wish, for any reason, to increase the proportion of pigment, or, what is the same thing, to decrease that of oil, we can do so by substituting a volatile thinner like turpentine for part of the oil. The viscosity of turpentine is about a quarter that of oil on our scale, and in practice it is reckoned that a gallon of turpentine thins a batch of

paint as much as two gallons of oil. We may, then, make a paint containing as little oil as we think best, and thin it to a working consistency with turpentine, and when it is dry we will have the desired proportion of oil and pigment. This is what we often do with white zinc; we make a paint too viscous to use, because we wish to keep the proportion of oil to pigment within a certain limit, and then thin it with turpentine. This does not give us more opacity, because the film is thinner when dry than it would have been if we had not used a volatile thinner, although it is more opaque than a film of the same thickness would have been if the paint had been thinned with oil alone, which would have had a less percentage of pigment. It is to be observed particularly that on account of the thinning power of turpentine being much more than that of oil, a turpentine-thinned paint has more pigment to the gallon, that is, to the same thickness of film, and so makes a more opaque film, than when only oil is used.

There is another way to thin a thick paint-mixture, or semi-paste paint, without using turpentine. It has already been said that the viscosity of mixtures of 3 parts of oil by volume to 1 of either barytes, whiting, or silica is much more fluid than similar mixtures of white lead. We may, therefore, make a three-to-one mixture of oil and zinc, and thin it with a similar mixture of one of these auxiliary pigments, and get a paint having a normal proportion of oil and pigment and at the same time have perfectly good working qualities. If these auxiliary pigments do not lessen the life of the oil such a paint ought to wear well, and while they have but little opacity they are at any rate more opaque than clear oil or turpentine. Moreover, such a paint is cheap, because these auxiliary pigments are cheap, which is an advantage; it is also a disadvantage, because it tempts the paint manufacturer to use them in excess, and it is well known that whatever may be their effect in small proportions, paints made of these auxiliary pigments alone with oil are of very little value as regards durability, and there must be a limit to their legitimate use. What this limit is, is not known to the writer, and he doubts if it is accurately known to any one, although some of the best of

the mixed-paint makers have a lot of experimental knowledge which they make use of, but do not communicate to the world at large. This limit may be small; it is certainly less for some pigments than for others; the American Society for Testing Materials is now undertaking an elaborate series of tests to determine these, among other, values.

White clay (kaolin, China clay) and asbestine are auxiliary pigments of a different sort; their viscosity in paints is high, and they increase the oil required instead of decreasing it. It is commonly believed that this quality, combined with the fact that their specific gravity is low, makes them useful to keep paints from settling in the can. They certainly make it possible to add benzine to the paint, and cheapen it.

If barytes, silica, or whiting mixed with oil in the ratio already mentioned be added to a similar mixture of white lead and oil, it will thin it, though to a less extent than with zinc because the difference is less. But there is no occasion to thin lead in this way, because when mixed in this proportion it is already thin enough to show the most perfect working qualities. It is often said that such mixtures, especially of barytes and lead, are as opaque as lead alone, within certain limits, such as 10 to 20 per cent. This simply is not the fact, and people who arrive at such results are not capable or do not know the necessary conditions of carrying out a proper painting test. The way these tests are conducted in the laboratory with which the writer is connected is substantially as follows (Thompson's method):

The test-panels are made of white-pine boards, 30 inches long by 10 inches wide, and $\frac{7}{8}$ inch thick. Each end of the board is provided with a cleat having a tongue fitting into a groove on the end of the board and securely nailed on. The entire board, including the cleats, to be finished to the size given above. Three of these boards are primed with, we will say, the following paint mixture:

White-lead paste	100 lbs.
Linseed-oil, one-third boiled	75 "

No attempt is made to secure a definite amount of priming paint to the unit of surface; this, for the reason that the boards may vary considerably in their absorptive power. When this priming coat is dry, each board receives a diagonal stripe of lampblack in japan about 1 inch wide on one or both sides of the board, as may be desired. When this black stripe is dry it is given a second coat of paint mixed to a consistency proper for painting, the formula being recorded. The weight per gallon of the paint so mixed is then obtained by finding its specific gravity and multiplying by 8.33, which gives the weight per gallon. Inasmuch as the board which we are using has a total surface of 680 square inches, all we have to do is to find what the ratio is between 680 square inches and the spreading rate at which we desire to apply the paint in order to find the fraction of the gallon which we wish to apply to each board. If the rate adopted is 1,200 square feet to the gallon, then we get the formula:

$$680 \text{ sq. in.} : 1,200 \text{ sq. ft.} :: 1 : x$$

the reciprocal of " x " being the fraction of a gallon of paint to be applied to each board, one coat. Having the weight of the paint per gallon we easily get the amount of paint by weight to apply to each board, one coat on all sides. When this second coat of paint is thoroughly dry, a similar coat is applied; and, when dry, the boards can be compared for the covering power of the paints on them. We mention the painting of three boards with each paint to be compared. The purpose of this is that variation in results are obtained between boards which are apparently painted in an identical manner. These variations are not great, but it is thought best to eliminate them, to a certain extent, by painting three boards and selecting the one giving medium results for comparison with boards painted with other paints.

Tests conducted along these lines, we believe, will give valuable and scientific results, and will enable the intelligent person to draw safe conclusions.

Let me state here, by way of illustration of the usefulness of this method, one of the results obtained by tests com-

paring pure white lead and linseed-oil with a mixture of white lead and a small amount of barytes with linseed-oil. The pure white lead was mixed on the formula of 100 lbs. of white-lead paste to 30 lbs. of linseed-oil; two mixtures containing barytes were made on the same formula as the white lead and pure linseed-oil, except that to the pure white lead was added an amount of barytes corresponding to 10 per cent by volume of the white lead present and the amount of oil was also increased 10 per cent, so that the mixed paint contained in each case the same percentage of pigment by volume and the same amount of oil by volume. Another mixture was made, adding 20 per cent by volume of barytes to the sample of white-lead paint and a corresponding amount of oil. These three paints were then compared by the above method for covering power and spread at the uniform rate of 1,200 square feet to the gallon. The result was that both paints containing barytes showed a very perceptible diminution in covering power. Now, this illustration has not for its purpose the saying of anything in favor of white lead and against barytes, but simply to show that if the statement is made that a small percentage of barytes can be added to white lead without impairing its covering power, some explanation must be made as to the method by which such a result is obtained. If in any painter's hands the result has been found that the addition of a small percentage of barytes did not impair the covering power of the white lead, it must have been due either to the fact that less oil was used, or that less surface was covered per gallon of the paint containing barytes than by the straight white lead.

No matter what the painting test may be, whether it be of colored paints or white paints, whether it be with homogeneous or mixed pigments, whether it be for covering power or durability, the essential features that we should insist upon are that the formula of the paint should be stated fully; that the thickness of the film—or what is the same thing, the rate at which the paint is spread—should also be stated. These two requisites of proper painting tests should also be demanded in all tests for the permeability of paint films or their permanency, no matter

how these tests may be applied. If we wish to compare two paint films for their permeability by the dextrine test, we should know, to start with, that these two films have approximately the same thickness. It is a safe assumption that the thicker the paint film, the less its permeability. If we desire to compare two paint films for their permanency, we should know that these two paint films are of the same thickness, as the elasticity and general life of the film are proportionate to its power of resistance to oxidizing influences, and the thicker the film the more permanent are its inner parts.

It may be thought difficult to apply a definite small amount of paint to a board as described; but it is not so. The paint is prepared of the proper proportions; a quantity considerably larger than is needed is put in a clean tin cup of capacity from a pint to a quart, the brush which is to be used is put in it; the cup is then weighed on a balance which will show tenths of a gramme; weights equal to the number of grammes of paint which is to be applied to the board are then removed from the weight-carrying scale-pan, so that when the right amount has been applied the scale will balance; then the painting is done. After a little practice, always using the same sized brush and the same sized board, the painter soon will get so that he can apply the requisite quantity, which in all tests of one series is the same in volume (which is all the painter cares about), within the limits of permissible error.

All the painting tests which the writer has seen or heard of indicate that pure white paints are less durable than colored ones, especially yellow and red. This is probably—indeed I am inclined to say, undoubtedly—due to the fact that white pigments are in their nature transparent, and appear opaque only because they reflect part of the light on account of the difference in refraction between them and the medium by which they are surrounded. Thus they allow a considerable part of the light to enter and reach the bottom of the film; as well the chemical rays as any others, and these chemical rays cause chemical action, and consequent destruction of the paint. But if the paint is black or red or yellow, these chemical rays are not allowed to

enter, and the paint lasts. Green approximates to yellow, and is pretty good, but light greens are rather easily destroyed; blues are almost as bad as white, and all light greens and blues are fugitive colors because they admit

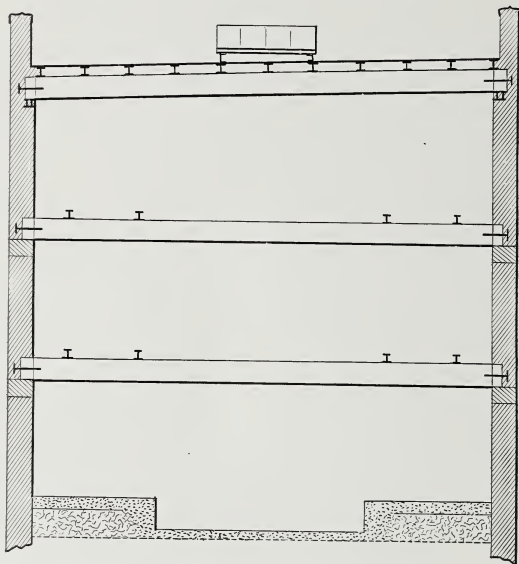

FIG. 48.—Section of a Varnish Storage-Building.

Courtesy of C. A. Willey, Long Island City, New York.

The floors are steel gratings, which allow the light from the sky-light to light the whole building. The tanks are set on cement benches on the lower floor; on I-beams, as shown, on the upper floors. The grating floors are carried on the heavy reinforced cement beams shown in longitudinal section. The walls are cement.

the actinic rays as every photographer knows, and they do not protect the oil. Even light tints of yellow and red, especially red-brown, make very durable paints; Venetian,



FIG. 49.—C. A. Willey's Varnish Storage; Lower Floor.

Indian, and Tuscan reds are the most permanent colors we have, on wood, except, perhaps, lampblack.

When paint perishes in service, it either wears off, progressively from the surface, or it peels off in flakes or scales from the bottom. The latter is worst, because always some of it adheres and it leaves a rough surface, unfit for repainting, especially as the portions which still adhere will probably flake off if paint is put over them. It is commonly said that this is a fault of white zinc; but zinc does not always do it, therefore it is a fault of the painter or the paint-maker. No doubt white zinc does do so frequently, but this only shows that it requires more care and skill than most other pigments; it must have the foundation carefully and correctly prepared (which ought to be done for all paints), and the right amount of oil must be used, which will vary with different surfaces. Its use is attended with more difficulties than that of white lead; but when used in the best possible manner it is an excellent paint. It is harder and less tough and elastic than white lead, and for that reason shows the effect of misuse and bad conditions worse than that paint; so much so that it is not often used in outdoor painting, in this country, without a considerable admixture of lead or other pigment, to make it more tractable. But it does not always show a tendency to peel, and therefore I do not believe it ever ought to do so. It is whiter than lead, and, unlike that pigment, does not become yellowish in places out of strong light, at least not appreciably; and it mixes with oleoresinous varnishes better than lead, which makes it generally used for enamels. This is remarkable, for it does not mix well with oil which is at all acid, and such oil is preferred for grinding lead; and the trouble with varnish as a vehicle is popularly supposed to be its acidity. Neither of these pigments will mix with shellac-varnish, but enter quickly into chemical combination with shellac, which is an acid resin.

White-lead paint, exposed to the weather, is said to "chalk," that is the oil on the surface either is destroyed or loses its binding power, and the lead may easily be rubbed off. This would not happen if it were converted by the action of the air into a soluble salt, which would be



FIG. 59.—C. A. Willey's Varnish Storage; Upper Floor.

washed off by the rain, nor if it was so loosely attached as to wash or blow away. It would be better, of course, if it lasted forever; but paints do not do that, and white paints especially. It is worth noticing that white lead colored with any pigment which resists actinic rays does not exhibit this chalking in anything like so considerable quantity as it does if left white. White zinc, contrary to the general belief, also chalks, if it has been used with such a proportion of oil and driers as to prevent it from cracking and peeling; but with zinc this is much less noticeable because it very often forms soluble salts, which in the first place are colorless and transparent, and in the second, are washed off by the rain.

If the observer will examine any external surface which has been painted with a paint containing a considerable proportion, say 25 per cent, of white zinc, during rainy or wet weather, he may notice that after rubbing the paint with a clean cloth, or even with the finger, something will come off having the peculiar bitter and styptic taste of zinc salts; and if he will subject this to chemical examination, zinc will be found in a soluble condition. M. G. Despierres, a white-zinc manufacturer and enthusiastic in its use, says that in the air near the sea, containing chlorides, the zinc in the paint tends to become chloride of zinc; and there is no doubt that, in the air of cities especially, the trace of sulphur in the air from the combustion of coal converts zinc into sulphate, which is also soluble. The lead salts, on the other hand, are all insoluble, at least all that are found in this way, and the fact that they remain in place gives some protection to the underlying and unchanged part of the film. It has seemed to the writer (but this is open to question) that in mixtures with white lead the latter seems to have a protective action on the zinc, while in mixtures with red lead the zinc seems to make the whole outer part of the film soften and decay. At all events, zinc is not a good material to put with red lead.

It will be seen that a sound opinion of a paint cannot be quickly arrived at, because paints all decay and houses have to be repainted. If one paint lasts in good condition five years and another six, the latter is the better unless

there is some other consideration; but if the first affords a good surface for repainting and the second is in such state that the old paint must be removed before repainting can begin, the cost of this removal will be so great that we can-



FIG. 51.—Steel Japan-Kettles. Lowe Bros. Co.

not afford to use it. A paint test is never ready for a report until the surface has been repainted at least once; and as any good outside paint lasts from three to five years,

and not infrequently twice that time, it is a slow business; and alleged tests which are completed in one or two years are really of little or no value. In 1906 the Am. Soc. for Testing Materials applied nineteen kinds of paint to a railroad bridge, and after five years all but one or two of these are in excellent condition; sample panels of all these were taken down and the paint dissolved off with alkali, in 1911, when it was found that the metal was very slightly and superficially injured in one or two cases, and in perfect condition in all the others. It will take ten years, and perhaps more, to judge these paints properly.

One thing seems certain: the paint chemist of the future must find out something definite about the effect of different pigments on oil. We know that different pigments make paints the films of which differ in important respects; we also know that the wetting power of oil is different for different pigments; that they bleach or color the oil differently; and any one can by a little calculation prove mathematically that if any pigment is mixed with oil or other vehicle in the proportion by volume of 1 to 3 the particles are separated by a layer of oil averaging not far from half their diameter in thickness. Now if the particles of one paint are three times finer than those of another, they will be three times as close together; they will have more surface in the aggregate, and, if they act on the oil, will do so more efficiently. These are not problems that any one man is likely to completely solve; but the more any one man knows about them the more he will know about the real constitution of paint; and, inevitably, about a great many other things, for these are not trivial matters, but deserve serious study.

It may, perhaps, be expected that the writer, who has for so many years been interested in the protection of iron from corrosion, should have something to add to the discussion of this subject. The list of references which is given in another place is fairly full, as regards current periodical literature; a very valuable treatise on the subject by Prof. J. N. Friend, with full references to earlier and contemporary writers, has just appeared; a little book by Mr. Alfred Sang, which came out a few years ago,

contains some acute and suggestive observations from the standpoint of a professional metallurgist; and, as will be seen by reference to the list of papers just referred to, some discussion and experimentation are being carried on in re-

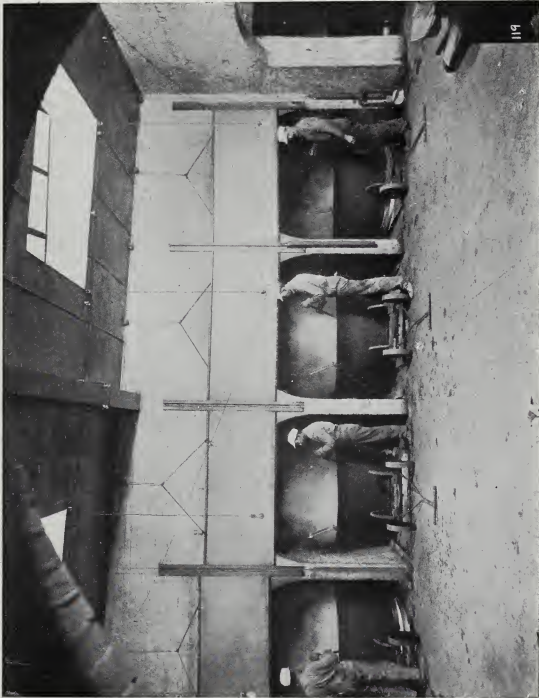

FIG. 52.—Making Japans and Driers. Lowe Bros. Co.

gard to the selection of pigments which may be supposed to stimulate or inhibit corrosion. Of those which are thought to prevent corrosion there are, chiefly, two classes:

one, those which are alkaline or basic, the other comprising the chromates, on account of the well-known power of



FIG. 53.—Turpentine Tanks. Louisville Varnish Co.

chromic acid to act on nascent hydrogen and to induce the “passive state” in iron.

In regard to the first, alkalies no doubt protect iron in most cases; but they attack and destroy the vehicle, and

that disposes of them. Some of the basic pigments, like red lead, have always been known to make reliable protect-



FIG. 54.—Varnish Storage. Louisville Varnish Co.

ive coatings, and their position is not seriously challenged by any one. The discussion just now (temporarily, I believe) is over the value of chromates. The chromates of lead and zinc undoubtedly make good paints either for

iron or wood; they have all the qualities that we look for in a good pigment; but that a chromate has virtue by being slightly or considerably water-soluble, when used in a drying oil as a vehicle, does not seem reasonable. If the experimenter will powder a little dry indigo and put it in linseed-oil, he will find that in a few hours it, though not apparently soluble, is reduced to white indigo. It is well known that only powerful reducing agents will effect this, even when the indigo is in actual solution; in this case it appears to be, both before and after reduction, an insoluble powder. Now, if linseed-oil is as powerful a reducing agent as this—and that it so acts may be shown in many other ways—it is difficult to believe that an unstable and active oxidizing agent like chromic acid will long remain unacted on by it. It is more reasonable to believe that when chromates make good paints it is because they are not soluble, and in being good pigments they conform to the laws which govern pigments in general.

So far as the writer knows, this matter has not gone beyond the stage of laboratory experiments and a few test panels, except as a matter of discussion and theory; as has been said, our knowledge of the true theory of paint is not yet large enough to warrant positive conclusions unsupported by experimental knowledge; and the whole situation is to-day about where it was ten years ago, except the natural progress in making materials and operations standard and uniform, such as the improvements in red-lead manufacture already described, and the increasing recognition of the need of more thorough work in application.

APPENDIX I

MISCELLANEOUS MATTER OF INTEREST TO
ANALYSTS

APPENDIX I

NOTES ON ANALYTICAL METHODS

IN the following compilation of data it is not the design of the writer to furnish a text-book of analysis; but to collect materials which either are not easily accessible, or are difficult to find. First on the list is the systematic course of analysis of Dr. P. H. Walker, chief chemist of the Contracts Laboratory of the Bureau of Chemistry in Washington. This is tolerably well known; but it is out of print, and it is uncertain whether it will be reprinted; probably not very many chemists have a copy. It is the most complete short treatise on the subject known to the writer, and it is printed complete. It consists of pp. 8-41 of Bulletin 109, of the Bureau of Chemistry.

The method of separating volatile oils from varnish and paint, given by Walker, is the well-known McIlhiney method, which has been variously modified. For many purposes it is usual to mix the liquid under examination with water and boil, without passing steam from another source.

Dr. McIlhiney's method for varnish analysis, while not sufficiently detailed in its results, furnishes data which are of value to an expert, and is the only systematic and scientific attempt to analyze varnish that has come to my notice. It appears to me to be capable of further development.

The large collection of data regarding resins made by Mr. Ch. Coffignier of Paris has been presented in a condensed form. For further investigation see his recent book on the manufacture of varnish. It is likely that some real knowledge of the nature of these resins may result from study of such facts, when supplemented by other investigations which they naturally suggest. The figures already given represent a great amount of work and deserve the fullest recognition.

In the examination of pigments, especially lead pigments, the work of the laboratory of the National Lead Company, under the direction of Mr. G. W. Thompson, has long been given freely to the chemical public, and some of the later methods are here published for the first time. The red-lead determination is new, rapid, and accurate.

Too little attention has heretofore been given to the real specific gravity of pigments; it is a matter of great importance technically.

Finally, the collection of references to oil, paint, and varnish literature requires comment. As editor of that section of the *Abstract Journal of the American Chemical Society*, the writer has from the first known its value. It might seem at first sight as if any one who has files of the Chemical Abstracts could easily look up the references for himself; but notwithstanding its excellent index, such is very far from being the case. At first the writer thought of editing these references, giving special prominence, by typographical means, to the more important, or leaving out such as were of little account; but a short trial showed the impracticability of this; no expert ever had knowledge enough to do it. Several schemes of classification were thought of, but nothing finally seemed of use except the obvious alphabetical arrangement of topics. Some indication of the subject of each paper would be desirable, an abstract of the abstract, but was found to be impossible. In its present form, covering the four volumes so far issued, it is believed that it will be found useful. Any one interested in an analytical method will be able to find, in most cases, considerable material, not only as to analysis, but as to the nature of the work he has undertaken, which latter is the foundation of analysis.

The *Journal* also gives a great number of patents. The consideration of these tends to make one a pessimist; and after much consideration and some vacillations, it was decided to leave them out entirely. This does indeed leave out some important things, which are to be known only in this way, such as bakelite, for example; but there is a loss either way.

These data are of value not only to the analyst, but to

the student of any branch of the subject; it is, however, necessary to keep them all together, and to put them somewhere, and this place seems, on the whole, most suitable.

ANALYSIS OF PAINT MATERIALS

[From *Bulletin No. 109, Revised, of the Bureau of Chemistry U. S. Department of Agriculture, by Dr. Percy H. Walker; Feb. 28, 1910.*]

Specific Gravity Determinations.—1. *Temperature Corrections:* It is almost the universal custom among oil chemists in this country to express the specific gravity of oils at 15.5° C. (60° F.) as compared with water at the same temperature. Since this temperature is generally far below that of the laboratory, the determination is frequently made at a higher temperature and the specific gravity calculated, using the formula $G = G' + K(T - 15.5^{\circ}$ C.), in which G = specific gravity at 15.5° C.; G' = specific gravity at T , and K = mean correction for 1° C.

The correction K varies somewhat for different oils, but the value $K = 0.00064$ may be taken as sufficiently accurate in most cases for both hydrocarbon and fatty oils.* These corrections, however, apply only to specific gravities referred to water at 15.5° C. (60° F.). The common custom of determining specific gravity at higher temperatures compared with water at the same temperature as the oil gives values to which this correction does not apply. If the correction is applied to such values, the results obtained for 15.5° C. will contain large errors. This is well illustrated by the following example:

The specific gravity of a sample of oil was carefully determined at two temperatures, with the following results:

$$(1) \text{ Specific gravity at } \frac{15.5^{\circ} \text{ C.}}{15.5^{\circ} \text{ C.}} = 0.9342.$$

$$(2) \text{ Specific gravity at } \frac{25^{\circ} \text{ C.}}{25^{\circ} \text{ C.}} = 0.9298.$$

* For the value of K for different fatty oils see Allen's "Commercial Organic Analysis," third edition, 2 (1): 33, and for lubricating oils see Archbutt and Deeley, "Lubrication and Lubricants," p. 183.

If the temperature correction is applied to the second value, the result is as follows: $0.9298 + 9.5 \times 0.00064 = 0.93588$ (specific gravity at 15.5° C.), an error far too large to be admissible. Now, from the known density of water at varying temperatures,* the specific gravity at $\frac{25^{\circ} \text{ C.}}{15.5^{\circ} \text{ C.}}$ may be calculated from equation 2, as follows:

$$0.9298 \times \frac{0.997071}{0.999050} = 0.92795.$$

If to this value the correction is applied the result is $0.92795 + 9.5 \times 0.00064 = 0.93403$, a value differing less than two in the fourth place from that actually determined, which is sufficiently accurate for most commercial work.

It is a simple matter to determine the specific gravity at any selected temperature as compared with water at 15.5° C., but to do so most easily it is necessary to properly calibrate the pycnometer or plummet. The coefficient of cubical expansion of glass varies somewhat, and, while this correction should be applied when necessary in calibrating, care should always be taken to apply the correction for only a few degrees. The Bureau of Standards in calibrating volumetric apparatus assumes the cubical coefficient of expansion of glass per degree centigrade as equal to 0.000025, and if this value is always used, on determinations within a very few degrees of the desired temperature, no appreciable error will be made. Since it is not safe to assume that the cubical coefficient of expansion of glass is the same for all temperatures, apparatus should be calibrated at a temperature very near that at which the determination is to be made.

2. *Westphal Balance*.—The Westphal balance, on account of its convenience, is frequently used in making specific-gravity determinations, but it is difficult to determine the errors for this instrument. The weights can be easily tested, but the divisions on the arm are not easily tested, and both may be somewhat incorrect. It is better

* Landolt, Bornstein, and Meyerhofer, "Physikalische Chemische Tabellen," pp. 37 to 39; Bureau of Standards, Circular No. 19, p. 27.

not to use a Westphal balance, but a plummet may be used on an analytical balance, which, when properly calibrated, is a very useful piece of apparatus, though the temperature is rather hard to control.

3. *Vacuum Weighing*.—It is not necessary to reduce weighings to vacuum, since the corrections entering in both numerator and denominator would not make any appreciable difference in the result. It should be understood that both in calibrating the apparatus and in making the specific-gravity determination all weights are made in air.

4. *Choice of Pyknometers*.—For the most accurate work with very fluid oils the Sprengel tube is the most accurate form. This apparatus is difficult to clean, and for ordinary work a specific-gravity bottle, with a cap to take up expansion, is the most convenient. A thermometer as part of the apparatus adds to the cost and has little or no advantage; in fact, it has some distinct disadvantages. Aside from errors in the thermometer, the liquid, if placed in the pyknometer at a low temperature and then allowed to stand at room temperature until the thermometer registers 15.5° C., may not be of the same temperature throughout.

If a pyknometer without a thermometer is used, it is necessary to bring it to its final temperature by keeping it in a bath for some time. By filling the pyknometer at about 14° C., inserting the stopper, and then placing it in a bath which is kept at 15.5° C. until no more liquid rises out of the capillary tube, one may be sure that the whole of the liquid in the pyknometer is at 15.5° C.

The form of pyknometer shown in Fig. 55 is excellent for

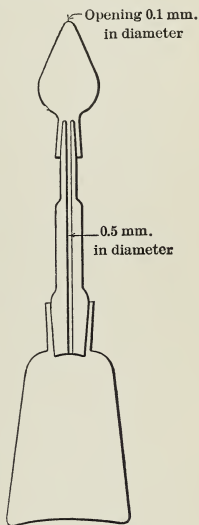

FIG. 55.

very fluid oils, but it is not suitable for those that are very viscous. For the latter use the form shown in Fig. 56.

5. *Calibration of Pyknometers.*—Clean and dry the pyknometer and weigh carefully after it has stood in the balance case for about thirty minutes. Fill with freshly

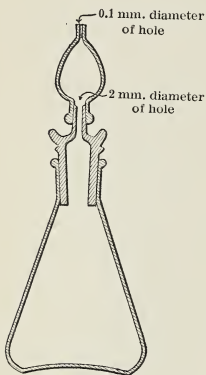

FIG. 56

boiled distilled water at about 14° C., insert the stopper, and place in a bath kept at exactly 15.5° C. When the temperature of the water in the pyknometer has risen to 15.5° C., which will be shown by the water ceasing to rise out of the capillary tube of the stopper, wipe off the water on the top of the stopper, place the cap on the stopper, remove from the bath, wipe dry, and let stand until it has come to room temperature, then weigh. This will give the water value of the pyknometer at 15.5° C. Calibrate the same pyknometer at 50° C., proceeding in the same way, except that the water used in filling the apparatus is about 47° C. and is brought up to 50° C. in a bath kept at exactly

that temperature. Multiply the weight of water at 50° C.

by $\frac{0.99905}{0.98807} = 1.011125$. This product is the water value

of the pyknometer at 50° C. In determining the specific gravity of any oil proceed as in calibrating, only substitute the oil for the freshly boiled water, and divide the weight of oil by the water value of the pyknometer. Results are

expressed in specific gravity at $\frac{15.5^{\circ} \text{ C.}}{15.5^{\circ} \text{ C.}}$ or $\frac{50^{\circ} \text{ C.}}{15.5^{\circ} \text{ C.}}$. If it

is desired to calibrate the instrument at any other temperature, proceed in a similar manner and multiply the weight of water found by the density of water at 15.5° C. (0.99905) and divide by the density of the temperature

used. (Use the tables of Landolt, Bornstein, and Meyerhofer, previously mentioned, p. 236.)

A plummet may be calibrated in a similar manner by calculating the water equivalent at 15.5° C. of the volume displaced at the different temperatures.

6. *Hydrometers*.—Hydrometers are frequently used by oil chemists, and when properly made are very good instruments. They should be calibrated at 15.5° C. (60° F.) and used at that temperature when exact results are desired. If a hydrometer is used at any other temperature (T), the

results should be recorded at $\frac{T}{15.5^{\circ}\text{C.}}$ and also reduced to

$\frac{15.5^{\circ}\text{C.}}{15.5^{\circ}\text{C.}}$ by applying the formula: $G = G' + K(T - 15.5^{\circ}$

C.). Unless the determination is made at the temperature at which the hydrometer is calibrated the result should not be relied on beyond the third place. If more exact results are desired, do not use a hydrometer.

7. *Arbitrary Scales*.—The expression of specific gravity in terms of arbitrary scales, such as Baumé, is very objectionable, since there are a number of Baumé tables in print which differ widely. It is sometimes necessary, however, to report specific gravity in degrees Baumé. When this is the case determine the specific gravity in the

usual manner, reduce, if necessary, to $\frac{15.5^{\circ}\text{C.}}{15.5^{\circ}\text{C.}}$ and find

the degrees Baumé by reference to an American standard table. Such a table has been recalculated and published by the Bureau of Standards, Circular 19, and is calculated by means of the following formulæ:

For liquids lighter than water:

$$B^{\circ} = \frac{140}{\text{Specific gravity at } 15.5^{\circ}\text{C.}} - 130.$$

For liquids heavier than water:

$$B^{\circ} = 145 - \frac{145}{\text{Specific gravity at } 15.5^{\circ}\text{C.}}$$

PAINT MATERIALS

Linseed-Oil.—1. *Preparation of Sample:* All tests are to be made on oil which has been filtered through paper at a temperature of between 15° and 30° C. immediately before weighing, with the exception of tests No. 6, Turbidity; No. 7, Foots; No. 9, Moisture and Volatile Matter, and No. 10, Ash. The sample should be thoroughly agitated before the removal of a portion for filtration or analysis.

2. *Specific Gravity.*—Determine with a pycnometer, plummet, or hydrometer at 15.5° C.

3. *Viscosity.*—Use the Engler-Ubbelohde method, making the determination at 20° C.

4. *Flash-Point, Open Cup.*—Set a nickel crucible 60 mm. in diameter at the top, 40 mm. in diameter at the bottom, and 60 mm. in height in a hole in the middle of a sheet of asbestos board 200 mm. square. The bottom of the crucible should project about 25 mm. through the asbestos. Support the asbestos on a tripod and suspend a thermometer reading to 400° C. in degrees in the centre of the crucible, so that the lower end of the thermometer is 10 mm. from the bottom of the crucible. Then pour in the oil until its level is 15 mm. below the top of the crucible. Place a Bunsen burner below the crucible and regulate the size of flame so that the thermometer rises 9° a minute. As a test-flame use an ordinary blowpipe attached to a gas-tube. The flame should be about 6 mm. long. Begin testing when the temperature of the oil reaches 220° C., and test for every rise of 3° . In applying the test move the flame slowly across the entire width of the crucible immediately in front of the thermometer and 10 mm. above the surface of the oil. The flash-point is the lowest temperature at which the vapors above the oil flash and then go out.

5. *Fire-Point.*—After noting the temperature at which the oil flashes continue the heating until the vapors catch fire and burn over the surface of the oil. The temperature at which this takes place is the fire-point. In determining the flash-point note the behavior of the oil. It should not

foam or crack on heating. Foaming and cracking are frequently caused by the presence of water.

6. *Turbidity*.—Note whether the oil is perfectly clear or not.

7. *Foots*.—Let a litre of the oil stand in a clear glass bottle for eight days and then note the amount of sediment formed. The highest grades of oil show no turbidity or foots by this test. The claim is made that sometimes what would be called foots by the above method is due to the freezing out of fats of rather high melting point. When a sufficient amount of the sample is available, heat one portion to 100° C. and set it aside for the determination of foots, together with a sample just as it is received. Note also the odor of the warm oil, rubbing it on the hands; a small amount of fish-oil may be detected in this way.

8. *Break*.—Heat 50 c.cm. of the oil in a beaker to 300° C. Note whether the oil remains unchanged or “breaks”; that is, shows clots of a jelly-like consistency.

9. *Moisture and Volatile Matter*.—Heat about 5 grammes of oil in an oven at 105° for forty-five minutes; the loss in weight is considered as moisture. This determination is of course not exact, as there is some oxidation. When a more accurate determination is desired, perform the whole operation in an atmosphere of hydrogen.

10. *Ash*.—Burn about 20 grammes of oil in a porcelain dish and conduct the ashing at as low a temperature as possible. The best oil should contain only a trace of ash. An amount as large as 0.2 per cent would indicate an adulterated or boiled oil. Examine the ash for lead, manganese, and calcium.

11. *Drying on Glass*.—Coat glass plates 3 by 4 inches with the oils to be examined, expose to air and light, and note when the film ceases to be tacky. A good oil should dry to an elastic coherent film in three days. Varying conditions of light, temperature, and moisture have such an influence on drying tests that for comparison of one linseed-oil with others all samples must be run at the same time.

12. *Drying on Lead Monoxide*.—Livache’s test calls for precipitated lead, but litharge gives equally good results.

Spread about 5 grammes of litharge over the flat bottom of an aluminum dish 2.5 inches in diameter and $\frac{5}{8}$ of an inch high; weigh the dish and the litharge; distribute as evenly as possible over the litharge 0.5 to 0.7 gramme of the oil, weigh exactly, expose to the air and light for ninety-six hours, weigh again, and calculate the gain in weight to percentage based on the original weight of the oil used.

13. *Acid Number*.—Weigh 10 grammes of oil in a 200-c.cm. Erlenmeyer flask, add 50 c.cm. of neutral alcohol, connect with a reflux air condenser, and heat on a steam bath for half an hour. Remove from the bath, cool, add phenolphthaleine, and titrate the free acid with fifth-normal sodium hydroxide. Calculate as the acid number (milligrammes of potassium hydroxide to 1 gramme of oil). The acid number varies with the age of the oil, and should be less than 8, though when the oil is refined with sulphuric acid it may show a higher acid number. Test for sulphuric acid.

14. *Saponification Number*.—Weigh from 2 to 3 grammes of oil in a 200-c.cm. Erlenmeyer flask, add 30 c.cm. of a half-normal alcoholic solution of potassium hydroxide, connect with a reflux air condenser, heat on a steam-bath for an hour, then titrate with half-normal sulphuric acid, using phenolphthaleine as indicator. Always run two blanks with the alcoholic potash. From the difference between the number of cubic centimetres of acid required by the blanks and the determinations, calculate the saponification number (milligrammes of potassium hydroxide to 1 gramme of oil). The saponification number should be about 190.

15. *Unsaponifiable Matter*.—As the saponification varies somewhat in pure oil, it is sometimes advisable to make a direct determination of unsaponifiable matter. Saponify from 5 to 10 grammes of oil with alcoholic potassium hydroxide (200 c.cm. of a half-normal solution) for an hour on a steam-bath, using a reflux condenser. Then remove the condenser and evaporate the alcohol as completely as possible; dissolve the soap in 75 c.cm. of water, transfer to a separatory funnel, cool, shake out with two portions of 50 c.cm. each of gasoline distilled between 35° and

50° C., wash the gasoline twice with water, evaporate the gasoline, and weigh the unsaponifiable matter, which in raw linseed-oil should be below 1.5 per cent; in boiled oil it is somewhat higher, but should be below 2.5 per cent.

16. *Iodine Number*.—Weigh in a small glass capsule from 0.2 to 0.25 gramme of oil, transfer to a 350 c.cm. bottle having a well-ground stopper; dissolve the oil in 10 c.cm. of chloroform and add 30 c.cm. of Hanus solution; let it stand with occasional shaking for one hour, add 20 c.cm. of a 10-per-cent solution of potassium iodide and 150 c.cm. of water, and titrate with standard sodium thiosulphate, using starch as indicator. Blanks must be run each time. From the difference between the amounts of sodium thiosulphate required by the blanks and the determination, calculate the iodine number (centigrammes of iodine to 1 gramme of oil). The iodine number of raw linseed-oil varies from 175 to 193, though Gill states that a pure raw oil may give a value as low as 160. Boiled oil may be very much lower.

Make the Hanus solution by dissolving 13.2 grammes of iodine in 1,000 c.cm. of glacial acetic acid which will not reduce chromic acid, and adding 3 c.cm. of bromine.

17. *Rosin or Rosin-oil (Liebermann-Storch Test)*.—To 20 grammes of oil add 50 c.cm. of alcohol, heat on a steam-bath for fifteen minutes, cool, decant the alcohol, evaporate to dryness, add 5 c.cm. of acetic anhydride, warm, cool, draw off the acetic anhydride, and add a drop of sulphuric acid, 1.53 specific gravity. Rosin or rosin-oil gives a fugitive violet color.

Spirits of Turpentine.*—1. *Color*: The best quality of spirits of turpentine should be water-white.

2. *Specific Gravity*.—Determine the specific gravity with a pycnometer, plummet, or hydrometer at 15.5° C. Pure gum turpentine should have a density between 0.862 and 0.875. Wood turpentine may, however, range from 0.860 to 0.910 or even higher.

3. *Distillation*.—Connect a distilling flask of 150 c.cm.

* If wood turpentine has been carefully refined, it will comply with all the tests given for spirits of turpentine, but it can almost invariably be distinguished from the latter by its characteristic odor.

capacity with a condenser having a thermometer. Introduce 100 c.cm. of turpentine and heat with a Bunsen burner. The initial boiling-point should be about 156° C., and 95 per cent should distil over between 153.5° and 165.5° C.

4. *Residue on Evaporation.*—Evaporate 10 grammes on the steam-bath; the residue should be less than 2 per cent.

5. *Refractive Index.*—Determine with a Zeiss direct-reading refractometer at 20° C. The index of refraction for gum turpentine should be from 1.4690 to 1.4740; for wood turpentine, 1.4685 to 1.5150.

6. *Action of Sulphuric Acid (Polymerization).*—Measure 6 c.cm. of turpentine in a stoppered, thin-walled tube graduated to 0.1 c.cm. (carbon tubes). Place the tube in cold water and pour in slowly a mixture of 4 parts of strong sulphuric acid and 1 part of fuming sulphuric acid. Add the acid slowly, and avoid an excessive rise in temperature. Shake the tube so as to mix the turpentine and the acid, add finally about 20 c.cm. of the acid, stopper the tube, mix thoroughly, cool, allow to stand thirty minutes, and note the volume of unpolymerized oil that collects on top of the acid layer. Then let stand for eighteen hours and again note the volume. A pure turpentine should show less than 0.3 c.cm. unpolymerized at the end of thirty minutes, and less than 0.5 c.cm. after eighteen hours.

This method will indicate gross adulteration, but will not detect admixtures of very small amounts of mineral oil. Donk has perfected a method which determines the presence of as little as 1 per cent of mineral oil in turpentine. This method is as follows:

Sulphuric acid of 38 times the normal strength (101.5 per cent) is prepared by mixing very strong sulphuric acid with fuming sulphuric acid. It must be determined by titration that this reagent is of the exact strength required, for with 37.5 times normal acid (100 per cent) the turpentine is not completely destroyed, and with acid stronger than 101.5 per cent the amount of mineral oil dissolved becomes excessive.

Place about 25 c.cm. of the special sulphuric acid in a

flask having a narrow graduated neck (a Babcock bottle does very well), cool in ice water, add 5 c.cm. of the turpentine to be tested and cool the flask again, shaking it carefully and avoiding any excessive rise in temperature by frequent cooling. The flask should never be too hot to hold in the palm of the hand. Then place it in a bath of cold water and heat the bath at such a rate that in about five minutes the temperature will be 65° C. During the heating shake the bottle about every fifty seconds, finally shaking very thoroughly so as to insure the contact of every particle of the sample with the acid. Cool to room temperature and add ordinary strong sulphuric acid in sufficient amount to bring the unpolymerized liquid up in the graduated neck. Let stand over night or whirl in a centrifuge and read the volume on the neck.

Pure turpentine should leave a residue of not over 0.04 c.cm., which is not limpid and which has a refractive index of not less than 1.500.

If the unpolymerized residue is 0.04 c.cm. or less, mineral oil may be assumed to be absent. If the residue is greater, calculate from it the percentage of mineral oil present. This will be, of course, only approximate, for there is some residue from pure turpentine and some mineral oil is dissolved by the acid; but for all practical purposes it may be assumed that the errors balance one another, and hence it is not advisable to apply any correction.

7. *Spot Test*.—Place a drop on filter-paper and allow it to dry at room temperature; it should leave no stain.

8. *Flash-point*.—Support a crucible, such as is used in determining the flash-point of linseed-oil, in a vessel of water at 15° to 20° C.; the water should cover about two-thirds of the crucible. Fill the crucible to within about 2 cm. of the top with turpentine, insert a thermometer, and heat the water-bath slowly, 1° per minute. Begin at 37° and test for the flash at each rise of 0.5° . The turpentine should not flash under 40.5° C.

Benzine and Light Petroleum Oils.—The term benzine is used for a number of light petroleum oils. In the painting trade it generally refers to a product of about 62° Baumé (0.7292 specific gravity). The petroleum benzine

of the U. S. Pharmacopœia is a lighter oil, being a light gasoline.

1. *Specific Gravity*.—Determine with a spindle, pycnometer, or plummet at 15.5° C. The determination can be made at room temperature and corrected to 15.5° C.

2. *Sulphur (Sodium Nitroprusside Test)*.—To 100 c.cm. of the sample in a flask add about 1 gramme of bright metallic sodium, connect with a reflux condenser, and boil for one hour. Cool, add water drop by drop until the metal is dissolved, separate the aqueous liquid, and test with a drop of sodium nitroprusside solution. A fine violet-blue coloration indicates sulphur.

3. *Sulphur Compounds and Pyrogenous Products (U. S. P. Tests)*.—To 100 c.cm. of the sample add 25 c.cm. of a solution of 10-per-cent anhydrous ammonia in 95-per-cent alcohol (spirit of ammonia U. S. P.), add 1 c.cm. of silver nitrate solution. Boil gently for five minutes. A brown coloration indicates sulphur compounds or pyrogenous products.

4. *Residue on Evaporation*.—Place 25 c.cm. in a 100 c.cm. platinum dish, heat on steam-bath for thirty minutes, and weigh residue. No residue should be left by this test.

5. *Fractional Distillation*.—Light petroleum oils are usually tested only for specific gravity; but as light and heavy distillates may be mixed, the specifications would be improved by requiring that a certain fraction should distil between specified temperatures. To make this determination distil 100 c.cm. in a round-bottom flask 6.5 cm. in diameter; the neck should be 1.6 cm. in diameter and 15 cm. long, with a side tube set in the middle of the neck at an angle of 75°. The surface of the liquid should be 9 cm. below the side tube, and the bulb of the thermometer just below the side tube.

6. *Benzole*.—Mix the sample with 8 volumes of strong sulphuric acid and 2 volumes of nitric acid; heat gently for ten minutes, allow to cool, and note odor. The odor of nitrobenzole indicates benzole.

7. *Color and Odor*.—Note color of sample and odor both in bulk and after rubbing on hands.

Dry Shellac.—1. *Detection of Rosin (Liebermann-Storch*

Test): To 1 gramme of the sample add 15 c.cm. of acetic anhydride, heat gently until solution is complete, cool, draw off the acetic anhydride, and add a drop of sulphuric acid 1.53 specific gravity. A fugitive violet color indicates rosin.

2. *Determination of Rosin (Langmuir's Method)*.*—To 0.200 gramme of ground shellac, in a 250-c.cm. dry bottle of clear glass with a well-fitting ground-glass stopper, add 20 c.cm. glacial acetic acid, and warm gently until the shellac is dissolved (a little shellac wax will remain undissolved, and at least half an hour should be allowed, for the shellac itself is difficultly soluble). Then add 10 c.cm. of chloroform and cool the solution down to 21° to 24° C. Add 20 c.cm. of Wijs's iodine monochloride solution, shake, and keep in the dark at a temperature between 21° and 24° C. for one hour, add 10 c.cm. of potassium iodide solution, and titrate immediately with thiosulphate—25 c.cm. may be run in at once and the remainder gradually with vigorous shaking, adding starch solution just before the end. The end point is sharp; any color returning after half a minute or so may be disregarded. If less than 25 c.cm. thiosulphate is required reject result and repeat determination, using a smaller quantity of shellac.

The Wijs solution may be made either by dissolving iodine monochloride in glacial acetic acid or by dissolving iodine in glacial acetic acid and passing in dry chlorine until the halogen content (figured as iodine) has nearly doubled; there may be a very slight excess of iodine, but there must be no excess of chlorine above the theory for iodine chloride. The halogen content figured as iodine should be about 26 grammes per 1,000 c.cm. The glacial acetic acid used must be free from reducing substances and have a melting point between 14.7° and 15° C. The thiosulphate solution should be a decinormal sodium thiosulphate solution. The potassium iodide solution is 10 per cent. Blanks must be run each time and the iodine number calculated from the difference between the titration result on the blank on the sample. Calculate the per cent of rosin, using the

* *Jour. Soc. Chem. Ind.*, 1905, xxiv. 12-17.

formula: $y = \frac{100}{N-M} \frac{A-M}{N-M}$, where y = per cent rosin, M = iodine number of shellac, N = iodine number of rosin, and A = iodine number determined.

In calculating the percentage of rosin, assume the iodine number for pure rosin to be 228, that for pure unbleached shellac to be 18, and for pure bleached shellac, 10. These figures will tend to give somewhat low results on rosin percentage, but should be used, as it is then safe to say that there is *at least* as much rosin present as is found by analysis.

3. *Alcohol Insoluble*.—Add to 1 gramme of shellac 60 c.cm. of 95-per-cent alcohol, heat to boiling and filter on a Gooch crucible; wash with about 60 c.cm. of boiling 95-per-cent. alcohol, dry at 100° C. and weigh.

4. *Loss on Drying—Water*.—Heat 1 gramme for two hours in a water-oven at 100° C. Loss in weight is calculated as water.

5. *Ash*.—Determine ash on 1 gramme, heating only to dull redness.

Shellac in Alcohol.—1. *Total Solids and Ash*: Evaporate 1 gramme of the varnish in a porcelain dish on the water-bath and dry to constant weight in steam-oven (about five hours). Ash residue as in dry shellac.

2. *Examination of Solvent*.—Note the odor of the varnish, as little can be learned from the odor of the distillate. Distil 100 grammes of the varnish until incipient decomposition begins: redistil the distillate, noting the boiling-point, and determine the specific gravity of the distillate. By this means it is usually an easy matter to determine whether the varnish is made with wood alcohol, grain alcohol, or denatured alcohol. Dilute a portion with three times its volume of water; if benzine is present it will separate.

3. *Test for Rosin*.—Do not use the residue from the total solids determination, but carefully weigh in a capsule a quantity of varnish sufficient to yield 0.2 gramme of solid material, evaporate to a paste, and treat the residue as described under "dry shellac," pars. 1 and 2, pp. 246, 247.

Dammar Varnish.—Dammar varnish, which should be a

solution of dammar gum in spirits of turpentine, is examined by the methods for oil-varnishes (p. 250). The percentage and nature of the volatile oil, specific gravity, and flash-point are important tests. It should yield little ash, which should contain no lead or manganese. When flowed on glass it should set to touch in a very short time (less than thirty minutes) and mixed with zinc white should yield a good white enamel surface when applied to wood.

In testing for rosin by the Liebermann-Storch test (p. 246), the light claret color characteristic of dammar should not be mistaken for the violet color characteristic of rosin. The Hirschsohn test for rosin, which is less delicate than the Liebermann-Storch method, is as follows:

Digest about 1 gramme of the dried resin with approximately 20 c.cm. of ammonium hydroxide for twenty minutes, filter, and acidify with acetic acid. With pure dammar the liquid remains clear, but if rosin is present a precipitate forms, and when the proportion of rosin is large the entire acid liquid may become gelatinous. The acid number of dammar is lower than that of rosin and higher than that of the hard varnish gums. An oil-varnish made of hard gums will generally have an acid number of less than 12. A dammar-varnish will have an acid number between 15 and 20, a higher number generally indicating the presence of rosin.

Oil-varnish.—The methods of an analysis for varnish are far from satisfactory. A number of methods for determining the amount of gums in varnish have been proposed, but none of them is reliable. This determination, therefore, is not made, but the combined percentage of oil and gums is reported.

1. *Appearance and Odor.*—Transfer the sample if it is in a metal container to a glass-stoppered cylinder or bottle and note its appearance, color, transparency, body, and whether any sediment is deposited. The presence of light petroleum-oil or wood turpentine may often be detected by noting the odor of the sample. After making these observations, the sample should be thoroughly mixed before making the remaining tests.

2. *Specific Gravity*.—Determine with a pyknometer, plummet, or hydrometer at 15.5°C .

3. *Flash-point*.—Determine as in spirits of turpentine; but begin testing at 25°C . and stir the varnish while heating. A low flash-point indicates light petroleum-oil.

4. *Viscosity*.—The determination of viscosity is seldom necessary; but if desired, make the determination by the Engler-Ubbelohde method at 20°C .

5. *Volatile Oils*.—Weigh 100 grammes of the varnish into a 500 c.cm. flask, connect with a spray-trap and a vertical condenser, and pass through it a current of steam, first heating the flask in an oil-bath at 100°C .; with the steam still passing through, raise the temperature of the bath to 130°C . Catch the distillate in a small weighed separatory funnel; continue distillation until 300 c.cm. of water has been condensed. Portions of this water may be drawn from the cock of the separatory funnel from time to time, but care must be taken not to draw out any of the volatile oil. Let the distillate stand until it separates into two layers, then draw off the water and weigh light oils. Filter the light oils through dry paper and examine as directed under spirits of turpentine (p. 243). A slight error is caused by the solubility of turpentine in water; this amounts to about 0.3 to 0.4 c.cm. for each 100 c.cm. of water.

When sufficient varnish is available, it is well to take another portion and distil, without steam or spray-trap, placing the weighed flask in an oil-bath. Note the temperature of the bath at which distillation begins, and continue distillation at a temperature of 185°C . in the oil-bath, finally raising the temperature to 200°C . This method generally tends to give lower results on volatile oils than the steam distillation method; but the distillate can be tested for water-soluble volatile liquids, which would be lost by the steam distillation.

6. *Fixed Oil and Gums*.—The percentage of fixed oil and gums is obtained by subtracting the percentage of volatile oils from 100. A check upon this determination is obtained by weighing the residue from the dry distillation.

7. *Acid Number*.—Determine the acid number in the usual way, using 10 grammes of varnish.

8. *Rosin*.—After getting the acid number, decant the alcohol, evaporate, and apply the Liebermann-Storch test for rosin (p. 246).

9. *Ash*.—Determine the ash in 10 grammes, using a quartz or porcelain dish and carrying out the determinations at a low heat, best in the muffle. Determine the reaction of the ash to litmus paper and make a qualitative analysis. It is frequently well to make a quantitative determination of lime, a large amount of which indicates rosin. It is sometimes advisable to determine the percentage of lead and manganese. Some lead will, however, be lost in the ashing, and if a correct lead determination is required, follow the method described for mixed paint vehicles (p. 283).

10. *Miscellaneous*.—It is not possible from such an examination as has just been described to decide on the value of a varnish for any particular purpose, though valuable information as to the materials used in its manufacture may be obtained. An examination of the varnish-film should, therefore, always be made. The films are best made by flowing the varnish on carefully cleaned plates of glass, and allowing to dry at room temperature in a vertical position. Observe the time of setting and the nature of the film after twenty-four hours, noting the transparency, hardness, elasticity, tendency to dust by scratching, etc. After thorough drying, immerse the plate in water over night, dry, and note appearance. The working quality of a varnish must be determined by application on wood, and it is best to make this test on well-seasoned and perfectly smooth white pine. Apply a thin coat of the varnish to wood and allow to dry, sandpaper down smooth, and then apply the coat to be tested. Observe how the varnish works under the brush, character of coat, etc. This panel, after drying, may be used for further testing as to whether the varnish will stand rubbing, etc.

Japan Drier.—The analysis of Japan drier is conducted in the same way as that of varnish. The following specifications for Japan drier for the Philadelphia & Reading

Railroad are given in an article by Job* on Practical Testing and Valuation of Japan:

The material desired consists of a pure turpentine hardener and oil drier, conforming to the following:

1st. When equal parts by weight of the Japan and of pure turpentine are thoroughly mixed and poured over a slab of glass, which is then placed nearly vertical at a temperature of 100° F., with a free access of air but not exposed to draft, the coating shall be hard and dry, neither brittle nor sticky, in not exceeding twelve minutes.

2d. When thoroughly mixed with pure raw linseed-oil at the ordinary temperature in proportions of 5 per cent by weight of Japan to 95 per cent by weight of raw linseed-oil, no curdling shall result, nor any marked separation or settling on standing.

3d. When the above mixture is flowed over a slab of glass, which is then placed nearly vertical at a temperature of 100° F., with free access to air but not exposed to draught, the coating shall dry throughout, neither brittle nor sticky, in not exceeding two hours.

4th. When 5 c.cm. of the Japan are poured into 95 c.cm. of pure turpentine at the ordinary temperature, and thoroughly shaken, a clear solution shall result, without residue, on standing one hour.

5th. After evaporation of the turpentine, the solid residue must be hard and tough, and must not "dust" when scratched with a knife.

6th. Benzine or mineral oil of any kind will not be permitted.

This, with the following specification of the U. S. Navy Department, will furnish a very good basis for an examination of Japan drier:

1. Japan drier must not flash below 105° F. (open tester); must be of the best quality and made from pure kauri gum, pure linseed-oil, pure spirits of turpentine, and lead manganese driers, and be free from adulterants and all other foreign materials; must set to touch in from one-fourth to one hour, dry elastic in from eighteen to twenty-

* *Chemical Engineer*, 1906, iv., 198-202.

one hour at a temperature of 70° F., and must not rub up or powder under friction by the finger. When mixed with pure raw linseed-oil in the proportion of 8 parts of oil to 1 part of drier, must remain clear for two hours and set to touch in from six to seven hours at a temperature of 70° F.

Paints.—*Strength Test:* The strength of pigments does not bear a very close relationship to the chemical composition, hence a quantitative analysis does not necessarily give the information actually desired. For this reason the "strength test" is of great importance. A standard color is usually selected, but in case no standard is used all of a series of similar colors may be compared with one another.

Weigh equal portions of the samples to be tested, and, if available, a standard sample; add to each equal portions of pure zinc oxide, the amount depending upon the character of the color tested (this may vary from 5 to 60 times that of the color). Rub up each mixture on a glass plate, or, better, a stone slab, until there is no change in shade on further rubbing. Rate the samples in the order of their depth of tint. White pigments may be rated in a similar way by grinding up each with the same colored pigment, such as Venetian red. With yellows use chrome green or Prussian blue instead of a white diluent. Add the same number of drops of raw linseed-oil to all samples in grinding for the strength test.

White Pigments.—1. *White Lead:* Pure white lead is basic carbonate of lead and should approach the following composition: $2\text{PbCO}_3\text{Pb(OH)}_2$. It should be completely soluble in acetic acid. Test for barium and calcium by the flame test. Use an iron wire, as platinum will be ruined by the lead.

(a) Total Lead.—Weigh 1 gramme of the sample, moisten with water, dissolve in acetic acid, filter and wash, ignite, and weigh the insoluble impurities. To the filtrate from the insoluble matter add 25 c.cm. of sulphuric acid (1:1), evaporate, and heat until the acetic acid is driven off; cool, dilute to 200 c.cm. with water, allow to stand for two hours, filter on a Gooch crucible, wash with 1 per cent sulphuric acid, ignite, and weigh as lead sulphate.

Calculate to total lead ($\text{PbSO}_4 \times 0.68292 = \text{Pb}$), or calculate to basic carbonate of lead (white lead) by multiplying the weight of lead sulphate by 0.85258.

The filtrate from the lead sulphate may be used to test for other metals, though white lead is only rarely adulterated with soluble substances; test, however, for zinc, which may be present as zinc oxide.

Instead of determining the total lead as sulphate it may be determined as lead chromate by precipitating the hot acetic acid solution with potassium dichromate, filtering on a Gooch crucible, igniting at a low temperature, and weighing as lead chromate.

(b) Complete Analysis.—When it is necessary to determine the exact composition of a pure white lead, heat 1 gramme of the pigment in a porcelain boat in a current of dry, carbon-dioxide-free air, catching the water in sulphuric acid and calcium chloride and the carbon dioxide in soda lime or potassium hydroxide (1.27 specific gravity). By weighing the residue of lead monoxide in the boat all the factors for determining the total composition are obtained. Figure the carbon dioxide to lead carbonate (PbCO_3), calculate the lead monoxide corresponding to the lead carbonate (PbCO_3) and subtract from the total lead monoxide, calculate the remaining lead monoxide to lead hydroxide ($\text{Pb}(\text{OH})_2$), calculate the water corresponding to lead hydroxide and subtract from the total water, the remainder being figured as moisture.

This method assumes the absence of acetic acid. Thompson* states that acetic acid varies from 0.05 per cent in Dutch process white lead to 0.7 per cent in some precipitated white leads. It is then more accurate to determine the carbon dioxide by evolution; this is especially the case when working with a lead extracted from an oil paste, as the lead soap and unextracted oil will cause a considerable error by the ignition method. In determining carbon dioxide by the evolution method, liberate the carbon dioxide with dilute nitric acid, have a reflux condenser next to the evolution flask, and dry the carbon dioxide with

* *Jour. Soc. Chem. Ind.*, 1905, xxiv., 487.

calcium chloride before absorbing it in the potassium hydroxide bulbs.

(c) Acetic Acid.—It is sometimes necessary to determine acetic acid. The Navy Department specifications demand that white lead shall not contain "acetate in excess of fifteen one-hundredths of 1 per cent of glacial acetic acid." Thompson's method* is as follows:

Eighteen grammes of the dry white lead are placed in a 500 c.cm. flask, this flask being arranged for connection with a steam supply, and also with an ordinary Liebig condenser. To this white lead is added 40 c.cm. of syrupy phosphoric acid, 18 grammes of zinc dust, and about 50 c.cm. of water. The flask containing the material is heated directly and distilled down to a small bulk. Then the steam is passed into the flask until it becomes about half full of condensed water, when the steam is shut off and the original flask heated directly and distilled down to the same small bulk—this operation being conducted twice. The distillate is then transferred to a special flask and 1 c.cm. of syrupy phosphoric acid added to insure a slightly acid condition. The flask is then heated and distilled down to a small bulk—say, 20 c.cm. Steam is then passed through the flask until it contains about 200 c.cm. of condensed water, when the steam is shut off and the flask heated directly. These operations of direct distillation and steam distillation are conducted until 10 c.cm. of the distillate require but a drop of tenth-normal alkali to produce a change in the presence of phenolphthaleine. Then the bulk of the distillate is titrated with tenth-normal sodium hydroxide, and the acetic acid calculated. It will be found very convenient in this titration, which amounts in some cases to 600–700 c.cm., to titrate the distillate when it reaches 200 c.cm. and so continue titrating every 200 c.cm. as it distils over.

If the white lead contains appreciable amounts of chlorine it is well to add some silver phosphate to the second distillation flask and not carry the distillation from this flask too far at any time.

* *Jour. Soc. Chem. Ind.*, 1905, xxiv., 487.

The method used by the chemists of the Navy Department is as follows: Weigh 25 grammes of white lead in an Erlenmeyer flask, add 75 c.cm. of 25-per-cent phosphoric acid, distil with steam to a 500-c.cm. distillate, add to the distillate some milk of barium carbonate, bring to a boil, filter, keeping the solution at the boiling-point (it is not necessary to wash), add an excess of sulphuric acid to the filtrate and determine the barium sulphate in the usual manner; subtract 53 mg. from the weight of the barium sulphate and calculate the remainder as acetic acid ($\text{BaSO}_4 \times 0.515 = \text{CH}_3\text{COOH}$). The object of this rather indirect method is to avoid any error that might arise from fatty acids being carried over by the steam distillation. For white lead that has not been ground in oil Thompson's method is to be preferred.*

2. *Lead Zinc Whites*.—French zinc is practically pure zinc oxide, being made from metallic zinc. American zinc is made by roasting zinc ores, and almost always contains some lead. Sublimed lead is made by volatilizing galena, and as sphalerite is usually associated with the galena, it nearly always contains zinc oxide in addition to the basic sulphate of lead. Zinc lead is essentially lead sulphate and zinc oxide.

(a) Moisture.—Dry 2 grammes for two hours at a temperature of 105°C .

(b) Soluble Sulphate.—Boil 1 gramme of the sample with 75 c.cm. of water and 25 c.cm. of alcohol, filter, wash with a mixture of alcohol and water (1 : 3), and determine sulphuric acid in the filtrate by the usual method of precipitation with barium chloride. The soluble sulphate may be calculated to zinc sulphate.

(c) Insoluble and Total Sulphate.—Treat 1 gramme in a 600-c.cm. beaker with 10 c.cm. of water, 10 c.cm. of strong hydrochloric acid, and 5 grammes of ammonium chloride, heat on a steam-bath in a covered beaker for five minutes, add hot water to make about 400 c.cm., boil for five minutes, and filter to separate any insoluble material. (A pure color should be completely dissolved.) Wash

* The so-called Navy Yard method has been discontinued.—A. H. S.

with hot water, ignite, and weigh the insoluble. To the boiling-hot filtrate add slowly, with stirring, 20 c.cm. of a 10-per-cent barium chloride solution; let stand for two hours on the steam-bath, filter, wash, ignite, and weigh as barium sulphate. Calculate the total sulphate (SO_4), deduct from it the soluble sulphate (SO_4), and figure the remainder as lead sulphate.

(d) Lead and Zinc.—(1) In the Absence of Other Metals: Dissolve 1 gramme by boiling fifteen minutes with 250 c.cm. of water and 20 c.cm. of strong nitric acid, add 5 c.cm. of sulphuric acid, evaporate, and heat until all of the nitric acid is driven off and copious fumes of sulphuric anhydride begin to come off; cool, dilute, filter on a Gooch crucible, wash with 1-per-cent sulphuric acid, ignite, and weigh as lead sulphate. Deduct from this the lead sulphate obtained from the sulphate determination and figure the remainder to lead monoxide. Evaporate the filtrate from the lead sulphate to 100 c.cm., cool, add 5 grammes of microcosmic salt dissolved in water, then add ammonium hydroxide until the solution is just neutral (test with litmus paper). Then add 2 drops of ammonium hydroxide and 1 c.cm. of acetic acid, stir vigorously, heat on the steam-bath for an hour (the precipitate should assume a crystalline character and settle well at the end of that time), filter on a Gooch crucible, wash with hot water, ignite at first at a very low heat and finally heat to redness, and weigh as zinc pyrophosphate ($\text{Zn}_2\text{P}_2\text{O}_7$), calculate to zinc oxide ($\text{Zn}_2\text{P}_2\text{O}_7 \times 0.53412 = \text{ZnO}$). Deduct the zinc oxide present as zinc sulphate and report the remainder as zinc oxide.

(2) In the Presence of Other Metals.—With a sample containing calcium or magnesium salts the lead should be precipitated as sulphide from hydrochloric acid solution, then dissolved in nitric acid, and determined as sulphate. The filtrates from the lead sulphide can be used to determine the zinc. If it is desired to make a gravimetric determination of zinc, boil off the hydrogen sulphide, add a little bromine water to oxidize any trace of iron, then add ammonium hydroxide in excess; only in rare cases will any iron appear here, but if it does, filter, redissolve, and

reprecipitate. Manganese will be present only very rarely; if present, it can be precipitated by adding bromine and warming. Make the zinc solution acid with acetic acid, heat to a boil, and pass hydrogen sulphide into the hot solution until it is completely saturated (for twenty to thirty minutes). Allow the zinc sulphide to settle for five hours, filter, wash with hydrogen sulphide water, dissolve the zinc sulphide in hot dilute hydrochloric acid, boil off the hydrogen sulphide, and determine the zinc as pyrophosphate, as described.

The hydrogen sulphide method is very troublesome on account of the difficulty of filtering and washing zinc sulphide, and when calcium or magnesium is present it is generally better to determine the zinc volumetrically. This is best done by Low's method.* In the absence of iron and manganese take the filtrate from the lead sulphide, add ammonium hydroxide until alkaline, then hydrochloric acid until just acid, then add 3 c.cm. of strong hydrochloric acid, dilute to about 250 c.cm., and titrate with standard ferrocyanide just as in standardizing the solution. When iron and manganese are present follow the method for oxidized ores as described by Low.

(e) Standardizing the Ferrocyanide Solution.—Prepare a solution of potassium ferrocyanide containing 22 grammes of the crystallized salt to the litre. Standardize this solution as follows: Weigh carefully about 0.2 gramme of pure zinc and dissolve in 10 c.cm. of strong hydrochloric acid (specific gravity 1.20), using a 400 c.cm. covered beaker. Dilute somewhat, place a bit of litmus paper in the solution as an indicator, and make faintly alkaline with ammonium hydroxide. Again acidify faintly with hydrochloric acid and then add 3 c.cm. excess of the strong acid. Dilute now to about 250 c.cm. and heat nearly to boiling.

Titrate the hot liquid with the ferrocyanide solution as follows: Pour off about one-third of the zinc solution and set it aside in a beaker. Titrate the remainder by running in a few cubic centimetres at a time until a drop, when tested on a porcelain plate with a drop of a 5-per-cent

* "Technical Methods of Ore Analysis," p. 209.

solution of uranium nitrate, shows a brown tinge. Now add the greater part of the reserved portion and continue the titration more cautiously until the end-point is again passed. Finally, add the last of the reserved portion, and to save rinsing out the beaker, pour a large part of the solution back into it again and then empty it once more.

Finish the titration very carefully, ordinarily by testing after each addition of 2 drops. Instead of using a single drop of the zinc solution for the test, the reaction is sharper if a quantity equivalent to several drops is taken. If this is done near the end of the titration the amount of zinc lost thereby will be insignificant. A convenient way of making the test is to use a medicine-dropper and place a single drop of the uranium solution in each depression of the test-plate at the outset. By using a glass tube instead of a rod for a stirrer, any desired quantity of the solution can be quickly removed for a test. When the final brown tinge is obtained, note the reading of the burette, and then wait a minute or two and observe if one or more of the preceding tests do not also develop a color. The end-point is always passed by a test or two and the burette reading must be corrected accordingly. A further correction must also be made for the amount of ferrocyanide required to produce a color under the same conditions when no zinc is present. This is ordinarily 2 drops. One c.cm. of the standard solution will equal about 0.005 gramme of zinc.

3. *Calcium Pigments*.—Whiting is calcium carbonate and is used extensively as an adulterant. Plaster of Paris is dehydrated calcium sulphate and gypsum is the natural hydrated calcium sulphate ($\text{CaSO}_4 + 2\text{H}_2\text{O}$). Besides these a precipitated calcium sulphate is used, especially as a basis upon which to precipitate aniline colors. A microscopic examination is therefore of importance.

Free lime is objectionable and is especially to be looked for in whiting. Boil 2 grammes of the sample for five minutes with 100 c.cm. of water and add phenolphthaleine. If red color develops, free lime may be assumed to be present, though the alkaline reaction may possibly be due to hydrates of sodium or potassium.

For quantitative analysis, when such is necessary, boil 1 gramme of the sample with 25 c.cm. of hydrochloric acid (1 : 1), add 150 c.cm. of water, boil, filter, wash, ignite, and weigh the insoluble. Precipitate iron and aluminum hydrates from the filtrate with ammonium hydroxide, dissolve in hydrochloric acid and reprecipitate, wash, ignite, and weigh. Unite the filtrates from the iron and alumina precipitation, heat to boiling, add slowly 25 c.cm. of a boiling solution of ammonium oxalate (the solution should be saturated at room temperature); let stand on the steam-bath for one or two hours, filter, wash free from chlorides (cold water is better for washing than hot water), and determine the calcium by igniting to constant weight in a platinum crucible. A blast-lamp is generally recommended for this purpose, but if a platinum triangle is used to support the crucible, from fifteen to thirty minutes' ignition with a good Bunsen burner will convert the oxalate entirely to oxide with less danger of loss than with a blast. If great accuracy is required, it is well to dissolve the calcium oxalate in hydrochloric acid and reprecipitate.

Instead of weighing the calcium as CaO, it may be determined volumetrically by titrating with potassium permanganate as follows: Precipitate as described, and wash free from ammonium oxalate (when free the filtrate will not react for chlorides). Return the moist precipitate to the beaker by washing with a stream of water, remove the small quantity remaining on the paper with hot dilute sulphuric acid, add 20 c.cm. of sulphuric acid (1 : 1), dilute to 300 c.cm., heat to about 80° C., and titrate with tenth-normal potassium permanganate (1 c.cm. = 0.0028 gramme of calcium oxide). Evaporate the filtrate from the calcium oxalate to about 100 c.cm., make neutral by the addition of hydrochloric acid, if necessary cool in ice-water, add an excess of a solution of sodium ammonium phosphate, stir, allow to stand for fifteen minutes, then add 20 c.cm. of strong ammonium hydroxide, stir well, allow to stand for two hours, filter in a Gooch, wash with 2-per-cent ammonium hydroxide, ignite gently at first and finally to a bright red, and weigh as magnesium pyrophosphate ($Mg_2P_2O_7$).

4. *Barytes*.—Barytes, being one of the cheapest white

pigments, is seldom adulterated. It should be white and well ground. A microscopic examination should be made to determine the evenness of grinding, the size and angularity of the particles, and whether they are amorphous or crystalline.

(a) Moisture.—Dry 2 grammes of the sample at 105° C. for two hours. The loss in weight represents the moisture.

(b) Insoluble.—Boil 1 gramme in hydrochloric acid (1 : 3), evaporate to dryness, moisten with hydrochloric acid, dilute with water, boil, filter, and wash. If a previous qualitative examination has determined the absence of lead and other easily reduced metals, ignite in platinum, weigh, and calculate the total insoluble; this may generally be safely calculated to barium sulphate (BaSO_4), but to determine any silica that may be present add hydrofluoric acid and sulphuric acid, evaporate the acids, ignite, and weigh; calculate the loss as silicon dioxide.

(c) Alumina and Oxides of Iron.—Add ammonium hydroxide to the filtrate from the total insoluble, boil, filter, wash, ignite, and weigh as oxide of iron and alumina.

(d) Lime.—Precipitate with ammonium oxalate from the filtrate from oxide of iron and alumina, filter, wash, ignite, and weigh as calcium oxide or titrate with potassium permanganate.

(e) Soluble Sulphate.—Boil 1 gramme with 20 c.cm. of strong hydrochloric acid, dilute to 200 c.cm. with hot water, boil, filter, wash, and determine the sulphate in the filtrate by precipitation with barium chloride in the usual manner. Calculate to calcium sulphate. If carbonates are present calculate the remaining calcium oxide to calcium carbonate (whiting); if carbonates are absent calculate the remainder as lime.

(f) Loss on Ignition.—Ignite 1 gramme in a platinum crucible. The loss in weight represents water (both free and combined with gypsum and kaolin), carbon dioxide from whiting, and organic matter.

Barytes should contain only small amounts of foreign matter, and there should be 95 per cent or more of barium sulphate present.

5. *Lithopone*.—Lithopone should contain about 65 per cent of barium sulphate, the remainder being zinc sulphide with small amounts of zinc oxide and carbonate. This substance is also called ponolith and Beckton white.

(a) Analysis of Pure Lithopone (Drawe).—(1) Moisture: Heat 2 grammes of the sample for two hours at 105° C. There should be less than 0.4 per cent of moisture.

(2) Insoluble and Total Zinc.—Take 1 gramme in a 200-c.cm. beaker, add 10 c.cm. of strong hydrochloric acid, mix, and add in small portions about a gramme of potassium chlorate; then heat on the water-bath until about half of the liquid is evaporated. Dilute with hot water, add 5 c.cm. of dilute sulphuric acid (1 : 10), boil, allow to settle, filter, wash, ignite, and weigh the insoluble which will be total barium as barium sulphate, together with any other insoluble. Make a qualitative examination for alumina and silica (not likely to be present). Heat the filtrate from the insoluble to boiling, add sodium carbonate solution, drop by drop, until all of the zinc is precipitated as carbonate, filter on a Gooch, wash, ignite, and weigh as zinc oxide.

(3) Zinc Sulphide.—Digest 1 gramme with 100 c.cm. of 1-per-cent acetic acid at room temperature for one-half hour, then filter and wash; determine the zinc in the filtrate as in the preceding analysis. The difference between the total zinc oxide and the zinc oxide soluble in acetic acid multiplied by 1.1973 gives the zinc present as sulphide. The zinc soluble in acetic acid may be reported as oxide, though it may be partly carbonate. This scheme of analysis assumes the absence of impurities such as salts of iron, etc., and is the method of P. Drawe.*

(b) Analysis of Lithopone in the Presence of Foreign Substances (Copalle).—Copalle † proposes the following method of analysis:

(1) Soluble Salts.—Wash 2 grammes with hot water and determine the nature of the soluble salts.

(2) Moisture.—Determine on 2 grammes the loss in weight on a steam-bath.

* *Zts. angew. Chem.*, 1902, xv., 174.

† *Ann. chim. anal. appl.*, 1907, xxii., 62-65.

(3) Insoluble.—Oxidize 1 gramme with nitric acid of 40° B. (1.38 specific gravity), at first cold, then hot. Then add hydrochloric acid, evaporate to very small volume, dilute with hot water, filter, ignite the precipitate which represents the barium sulphate corresponding to the total barium. If the insoluble exceeds 66 to 68 per cent it is necessary to prove that the excess is not due to the addition of kaolin.

(4) Total Zinc.—Determine as oxide by precipitation as carbonate in the filtrate from the insoluble. When more than traces of iron, alumina, or lime are present, it is best to determine the zinc volumetrically.

(5) Sulphide of Zinc.—Add a slight excess of hydrochloric acid to the filtrate from the zinc carbonate and determine the sulphur by precipitation in the usual manner. This sulphur multiplied by 3.03, or the weight of barium sulphate (BaSO_4) multiplied by 0.4603, gives the zinc sulphide.

(6) Oxide of Zinc.—Multiply the weight of the zinc sulphide by 0.835 to obtain the zinc oxide corresponding to the sulphide. Subtract this from the total zinc oxide and report the remainder as zinc oxide (it may be present as oxide or as carbonate).

(7) Barium Carbonate.—Digest 2 grammes with boiling dilute hydrochloric acid, dilute with hot water, filter from the insoluble, and determine the barium in the filtrate by precipitation with sulphuric acid. The weight of the barium sulphate multiplied by 0.845 gives the barium soluble in the acid calculated as carbonate.

(8) Barium Sulphate.—Subtract the barium sulphate corresponding to the carbonate from the total barium sulphate.

6. *General Scheme of Analysis for a White Pigment.*—The pigment may contain white lead, lead sulphate, zinc oxide, baryta, whiting, kaolin, or other silicates, and, in fact, any mixture of white pigments, except lead compounds and zinc sulphide together, as such a mixture has a tendency to blacken.

Dry 2 grammes of the sample for two hours at 105° C. Treat 1 gramme in a beaker with 25 c.cm. of water and 10 c.cm. of acetic acid (95 per cent); boil, filter, and wash

with water. Pass hydrogen sulphide into the hot filtrate, collect the lead sulphide and zinc sulphide on a filter, wash, dissolve in nitric acid, precipitate, and weigh the lead as sulphate in the usual manner; calculate to white lead. In the filtrate from the lead sulphate determine the zinc either by the gravimetric or the volumetric method, and calculate to zinc oxide. Test the filtrate from the lead sulphide and the zinc sulphide for barium, calcium, and magnesium, determine in the usual manner, and calculate to carbonates. Transfer the residue from the acetic acid digestion to a beaker, add 10 c.cm. of water, 10 c.cm. of strong hydrochloric acid, and 5 grammes of ammonium chloride, heat on a steam-bath for five minutes, dilute with hot water to 400 c.cm., boil five minutes, filter, wash, ignite, and weigh the insoluble. Make a qualitative test of the insoluble. Precipitate the lead from the filtrate from the insoluble with hydrogen sulphide, dissolve in nitric acid, determine as sulphate, and calculate as lead sulphate. In the filtrate from the lead sulphide determine the alumina and the calcium in the usual manner; calculate the calcium found to calcium sulphate.

Black Pigments.—Black pigments are practically all carbon black in one form or other. They should be tested for oil by washing with ether. Good-quality black should be free from oil. Blacks which are alike chemically may behave very differently when ground in thin varnish. For example, lampblack mixed with such varnish in a ratio of 20 : 100 has flow, while gas-black similarly treated has no flow.

1. *Manufactured Blacks.*—(a) Moisture: Dry 2 grammes for two hours at 105° C. The loss in weight represents the moisture.

(b) Volatile Matter.—Heat 1 gramme in a well-covered platinum crucible for seven minutes with a Bunsen flame 20 cm. high. The crucible should weigh about 25 grammes, have a well-fitting top, and be supported on a platinum triangle 7 cm. above the top of the burner.

(c) Ash.—Ash 2 grammes, preferably in a muffle, and weigh.

(d) Soluble and Insoluble Ash.—Add to the ash from

2 grammes of black 25 c.cm. of hydrochloric acid (1 : 1), evaporate to dryness on a steam-bath, add 5 c.cm. of hydrochloric acid, dilute with 75 c.cm. of water, filter through a Gooch, wash, ignite, and weigh the insoluble ash.

(e) Adulterations.—Blacks are occasionally adulterated with Prussian blue. To determine this point boil the sample with 4 per cent sodium hydroxide, filter, render the filtrate acid with hydrochloric acid, and add a solution of a mixture of ferrous and ferric chloride or sulphate. A blue precipitate indicates the presence of Prussian blue. At least one black on the market contains a large amount of a magnetic oxide of iron, which may be readily detected by the action of a magnet. The ash of ivory and bone-blacks should contain a large amount of calcium phosphate.

2. *Graphite*.—Graphite is more of a gray pigment than a black. The finer grades are used as lubricants and in making lead-pencils. All commercial graphite contains a considerable quantity of ash. For analysis, determine the moisture as usual, boil with hydrochloric acid, filter, dry, and weigh, then ignite; it may be necessary to use oxygen to insure complete combustion; the loss is taken as carbon. If a previous test has shown the absence of carbonates, the treatment with hydrochloric acid may be omitted. Graphite used as a lubricant is sometimes adulterated with soft coal. Good Ceylon graphite is practically unaffected by hot sulphuric acid and potassium sulphate, while soft coal is completely decomposed. A fairly good quantitative determination of soft coal in graphite is made as follows:

Determine the moisture and the ash in one portion, and calculate the total carbon by difference. Treat 1 gramme in a Kjeldahl digestion-flask with 30 c.cm. of strong sulphuric acid and 2 grammes of potassium sulphate. Heat for two hours at a temperature about the fuming-point of the sulphuric acid, cool, add water, filter, wash, dry at 105° C., and weigh; then ignite until all of the carbon is burned; the loss here represents the carbon as graphite, and the difference between this determination and that of total carbon represents the soft coal.

Colored Pigments.—1. *Yellow, Orange, and Red Pigments*: The most important yellow pigment is chrome-yel-

low, which varies in shade from a light lemon-yellow to a deep orange. The lighter shades generally contain lead sulphate as well as lead chromate, while the deep orange contains some basic lead chromate. Pure chrome-yellow should contain only lead chromate, lead sulphate,* and possibly some basic lead in the darker shades. Zinc-yellow is zinc potassium chromate of a composition approximating the following formula: $(\text{ZnCrO}_4)_3\text{K}_2\text{Cr}_2\text{O}_7$.

(a) Chrome-yellow.—(1) Moisture: Dry 2 grammes for two hours at 105°C .

(2) Insoluble Impurities.—Treat 1 gramme with 20 c.cm. of strong hydrochloric acid, cover and heat on a steam-bath for fifteen minutes, add 100 c.cm. of hot water, boil (the solution should be complete), filter, wash, ignite, and weigh the insoluble impurities.

(3) Lead.—Evaporate the filtrate from the insoluble to about 2 c.cm., but not to dryness, add 100 c.cm. of 95-per-cent alcohol, stir, allow to stand for one hour, cool in ice-water, filter on a Gooch crucible, wash with 95-per-cent alcohol, dry for one hour at 110°C ., cool, and weigh as lead chloride. Add 0.0085 gramme to the weight of the lead chloride to correct for its solubility in alcohol. Multiply the result thus obtained by 0.74478 to obtain the amount of lead present.

(4) Chromium.—Evaporate the filtrate from the lead chloride determination to dryness on a steam-bath to expel the alcohol, add about 5 c.cm. of hydrochloric acid, then about 50 c.cm. of water, and warm till the solution is complete. Cool, transfer to a volumetric flask, and make up to a definite volume. To an aliquot add sodium peroxide in sufficient amount to render the solution alkaline and to oxidize the chromium to chromate, boil until all of the hydrogen peroxide is driven off, cool, make acid with sulphuric acid, add a measured excess of standard ferrous sulphate, and titrate the excess of iron with standard potassium dichromate.

(5) Sulphate.—In another aliquot of the filtrate from the

* Lead sulphate may be replaced by other insoluble lead compounds. A chrome-yellow should be considered adulterated if it contains anything besides insoluble lead compounds.

lead-chloride determination, determine the sulphate in the ordinary way by precipitation and weigh as barium sulphate.*

(6) Treatment in the Presence of Soluble Impurities.—If the sample contains no soluble impurities, the preceding method will give a complete analysis. When the qualitative test shows calcium it may be necessary to make the analysis in a somewhat different manner, for gypsum would by this treatment be precipitated with the lead chloride and render the determination worthless. In such a case dissolve and separate the insoluble as above. Dilute the filtrate from the insoluble to 400 c.cm., cool, pass in a rapid stream of hydrogen sulphide until all of the lead is precipitated as lead sulphide, filter, wash with water containing some hydrogen sulphide, dissolve the lead sulphide in dilute nitric acid (hot), add an excess of sulphuric acid, heat to fumes, and complete the determination of lead as sulphate in the usual way. In the presence of chromium the solution must be very dilute and the hydrogen sulphide passed in rapidly to get a good separation of lead as sulphide. Transfer the filtrate from the lead sulphide to a 500-c.cm. flask, add ammonium hydroxide until it is slightly alkaline, pass in hydrogen sulphide until all of the zinc present is precipitated (in case no zinc is present the addition of hydrogen sulphide is unnecessary); make up to volume, mix, allow to settle, draw off aliquots of the clear liquid, and determine the calcium (and, if necessary, the magnesium) in the usual way. All the zinc and chromium will still be in the 500-c.cm. flask; dissolve in hydrochloric acid, make up to the mark, mix, take out an aliquot, and determine the zinc volumetrically by the ferrocyanide method as described under lead-zinc whites. In another aliquot determine chromium as already described.

Sulphate can be determined by dissolving another portion in hydrochloric acid, filtering from it the insoluble, and precipitating with barium chloride from the dilute

* Some chromes contain barium phosphate instead of lead sulphate, in which case test for phosphoric acid. Or barium sulphate, calcium sulphate, etc., may replace lead sulphate. Lead citrate is also sometimes present instead of lead sulphate.

hot filtrate; if the solution is kept dilute and hot, the barium-sulphate precipitate will not be contaminated by lead.

(b) Zinc-yellow.—(1) Moisture: Dry 2 grammes for two hours at 105° C.

(2) Insoluble Impurities.—To 1 gramme of the dry pigment add 25 c.cm. of strong ammonium hydroxide, stir well, and dilute to about 100 c.cm. with water, stir frequently for about thirty minutes, carefully breaking up all lumps, but do not heat. Filter and wash with dilute ammonium hydroxide and then with water, dry residue at 105° C. to constant weight, and weigh, then ignite and weigh again. If desired, dissolve the residue in hydrochloric acid and analyze in the usual manner.

(3) Soluble Zinc, Chromium, and Potassium.—Heat the filtrate from the determination of insoluble impurities to boiling in a graduated flask, pass in hydrogen sulphide until all of the chromate is reduced and the zinc is precipitated as zinc sulphide and chromium as chromium hydroxide. Fill to the mark, mix, allow to settle, draw out an aliquot of the clear liquid, and determine alkalis by adding sulphuric acid, evaporating to dryness, igniting, and weighing as mixed sulphates. If desired, potassium may be determined as potassium platonic chloride (K_2Pt_6Cl). Add hydrochloric acid to the residue in the flask and determine zinc and chromium as in chrome-yellow.

(4) Impure Samples.—The preceding methods will serve only for samples which are pure or adulterated only with substances insoluble in ammonium hydroxide. Very impure samples should be examined as described under chrome-yellow, page 266.

(c) Red Lead and Orange Mineral.—These pigments in the pure state are oxides of lead (approximately Pb_3O_4), being probably mixtures of compounds of varying proportions of lead monoxide and lead dioxide. Moisture, insoluble impurities, and total lead may be determined by the methods given under chrome-yellow; or, in the absence of alkaline earth metals, the lead may be determined as sulphate in nitric-acid solution (dissolve by adding a few drops of hydrogen dioxide) by evaporating with an excess

of sulphuric acid until fumes of sulphuric anhydride are evolved. Determine as sulphate in the usual way.

The lead dioxide (PbO_2) may be determined as follows: Weigh 0.5 gramme of the very finely ground pigment into a 150-c.cm. Erlenmeyer flask. Mix in a small beaker 15 grammes of crystallized sodium acetate, 1.2 grammes of potassium iodide, 5 c.cm. of water, and 5 c.cm. of 50-per-cent acetic acid. Stir until all is liquid, pour into the Erlenmeyer flask containing the lead, and rub with a glass rod until all of the lead is dissolved; add 15 c.cm. of water, and titrate with tenth-normal sodium thiosulphate, using starch as indicator. A small amount of lead may escape solution at first, but when the titration is nearly complete this may be dissolved by stirring. The reagents should be mixed in the order given, and the titration should be carried out as soon as the lead is in solution, as otherwise there is danger of loss of iodine. One cubic centimetre of tenth-normal sodium thiosulphate corresponds to 0.011945 gramme of lead dioxide, or 0.034235 gramme of red lead (Pb_3O_4).

These colored lead pigments may have their color modified by the addition of organic coloring-matters. As a general rule, such adulteration may be detected by adding 20 c.cm. of 95-per-cent alcohol to 2 grammes of the pigment, heating to a boil, and allowing to settle. Pour off the alcohol, boil with water, and allow to settle, then use very dilute ammonium hydroxide. If either the alcohol, water, or ammonium hydroxide is colored, it indicates organic coloring-matter. The quantitative determination of such adulteration is difficult and must generally be estimated by difference.

(d) Vermilion.—True vermilion, or, as it is generally called, English vermilion, is sulphide of mercury. On account of its cost it is rarely used in paints, and is liable to gross adulteration. It should show no bleeding on boiling with alcohol and water and no free sulphur by extraction with carbon disulphide. A small quantity mixed with five or six times its weight of dry sodium carbonate and heated in a tube should show globules of mercury on the cooler portion of the tube. The best test for purity

is the ash, which should be not more than $\frac{1}{2}$ of 1 per cent. Make the determination in a porcelain dish or crucible, using 2 grammes of the sample. Ash in a muffle or in a hood with a very good draught, as the mercury fumes are very poisonous. It is seldom necessary to make a determination of the mercury; but if this is required, it may be determined by mixing 0.2 gramme of the vermilion with 0.1 gramme of very fine iron filings, or better "iron by hydrogen." Mix in a porcelain crucible and cover with a layer 10 mm. thick of the iron filings, place the crucible in a hole in an asbestos sheet so that it goes about half-way through, cover with a weighed, well-fitting, gold lid which is hollow at the top, fill this cavity with water, heat the crucible for fifteen minutes with a small flame, keep the cover filled with water, cool, remove the cover, dry for three minutes at 100° C., and thirty minutes in a desiccator, and weigh. The increase in weight is due to mercury. The mercury can be driven off from the gold by heating to about 450° C. A silver lid may be used, but gold is much better.

Another method is to place in the closed end of a combustion tube, 45 cm. long and 10 to 15 mm. in diameter, a layer of 25 to 50 mm. of roughly pulverized magnesite, then a mixture of 10 to 15 grammes of the vermilion with four or five times its weight of lime, followed by 5 cm. of lime, and plug the tube with asbestos. Draw out the end of the tube and bend it over at an angle of about 60° . Tap the tube so as to make a channel along the top, and place it in a combustion furnace with the bent neck down, resting with its end a little below some water in a small flask or beaker. Heat first the lime layer, and carry the heat back to the mixture of lime and pigment. When all the mercury has been driven off, heat the magnesite, and the evolved carbon dioxide will drive out the last of the mercury vapors. Collect the mercury in a globule, wash, dry, and weigh.

Genuine vermilion is at the present time little used in paints. Organic lakes are used for most of the brilliant red, scarlet, and vermilion shades. These organic coloring-matters are sometimes precipitated on red lead, orange

mineral, or zinc oxide; but as a usual thing the base is barytes, whiting, or china clay. Paranitraniline red, a compound of diazotized paranitraniline and beta-naphthol, is largely employed; but a number of colors may be used. To test for red colors in such a lake the following method from Hall* may be of value, though other colors may be employed, which makes the table of only limited use.

It is well also to try the action of reducing and oxidizing agents such as stannous chloride, ferric chloride, etc. (See Zerr, "Bestimmung von Teerfarbstoffen in Farblacken"; also Schultz and Julius, "A Systematic Survey of the Organic Coloring Matters.")

Paranitraniline red is soluble in chloroform. It is also well to try the solvent action on different reds of sodium carbonate, etc. The amount of organic pigment present in such reds is generally very small, and when it cannot be determined by ignition owing to the presence of lead, zinc, or carbonate, it is best determined by difference.

2. *Oxide and Earth Pigments.*—Iron oxide is extensively used as a paint. The native oxide naturally varies very much in its composition. In general, however, only the poorer grades of native hematite are used as paints. Artificial iron-oxide pigments, made by calcining copperas, may be practically pure ferric oxide. Umbers, ochers, and siennas are earthy substances containing iron and manganese oxides and more or less organic matter.

The methods of analysis are very much the same as those for iron ores. It is generally sufficient to determine moisture, loss on ignition, insoluble in hydrochloric acid, ferric oxide, and manganese dioxide. If much organic matter is present, roast 2.5 grammes in a porcelain dish at a low temperature until all organic matter is destroyed, add 25 c.cm. of hydrochloric acid, cover with a watch-glass, and heat on the steam-bath for two hours; then add 10 c.cm. of sulphuric acid (1 : 1), evaporate, and heat until fumes of sulphur trioxide are evolved and all the hydrochloric acid is driven off. Cool, add 50 c.cm. of water, boil until all of the iron sulphate is dissolved, filter into

* "The Chemistry of Paints and Paint Vehicles," p. 29.

DETERMINATION OF RED COLORS IN ORGANIC LAKE (HALL)

REAGENT.	SOURCE OF COLOR.				
	Alizarine.	Eosine.	Paranitraniline.	Ortho-anisidine.	Scarlet (2R).
Sulphuric acid, conc.	Dark-brown with reddish undertone becoming light-yellow on diluting.	Changes to yellow; fluorescent solution with excess of sodium hydroxide.	Purple; color returning on diluting.	Purple; red on diluting.	Darkened; lighter on diluting.
Hydrochloric acid, conc.	Color becomes "muddy."	Changes to yellow; reddish fluorescent solution with excess of sodium hydroxide.	Color slightly darkened; lighter on diluting.	Dark purplish-red; lighter on diluting.	Darkened; lighter on diluting.
Sodium hydroxide, conc. sol.	Dark reddish-brown; little change on diluting.	Little change; fluorescent solution on diluting.	Color changed to brownish-red; light-red on diluting.	Little change.....	Reddish solution on diluting.
Alcohol.....	Insoluble.....	Reddish fluorescent solution.....	Slight yellowish-orange solution.	Slight reddish solution.
Sodium hydroxide, conc. and alcohol.	Purplish; dark-brown on diluting.	Purple; color returning on diluting.	Little change.....	Color darker; reddish solution on diluting.

a 250-c.cm. graduated flask, fill to the mark, mix, and take out a portion of 50 c.cm. for iron determinations. For the determination of iron reduce with zinc, titrate with standard potassium permanganate, and calculate to ferric oxide. For the determination of manganese transfer 100 c.cm. of the solution (corresponding to 1 gramme) to a 500-c.cm. flask, add sodium-hydroxide solution until nearly but not quite neutral. Then add an emulsion of zinc oxide in water in slight excess, shake until all of the iron is thrown down, fill to the mark, mix, let settle, filter through a dry paper, and use portions of 100 c.cm. (corresponding to 0.2 gramme) for the manganese determination. Transfer to a 300-c.cm. Erlenmeyer flask, heat to boiling, titrate with standard permanganate. The flask must be shaken during the titration and some experience is necessary to determine the end point, which is best seen by looking through the upper layer of liquid and observing when the pink tinge from the permanganate does not disappear on shaking. A standard potassium-permanganate solution, the iron factor of which is known, may be used to determine manganese. The iron factor multiplied by 0.2952 gives the manganese factor. In some cases this method of attack will not separate all of the iron from the insoluble matter. In such a case the insoluble must be fused with a mixture of sodium and potassium carbonates, dissolved in water, evaporated with excess of sulphuric acid, filtered from the insoluble, and this solution added to the first one.

Another method is as follows: Roast 5 grammes of the powder, digest with 25 c.cm. of hydrochloric acid, evaporate to dryness, moisten with hydrochloric acid, dissolve in water, filter, and wash the residue; ignite the residue in a platinum crucible, add sulphuric acid and hydrofluoric acid, drive off the latter, and heat until copious fumes of sulphuric anhydride come off. Add potassium hydrogen sulphate and fuse, dissolve in water, filter from any remaining insoluble (barium sulphate), unite the two solutions, make up to 500 c.cm., and use aliquots for the iron and manganese determinations. For the determination of iron place 100 c.cm. in a flask, add about 3 grammes of

zinc, put a funnel into the neck of the flask, heat when the action slackens; if basic salts separate out, add a few drops of hydrochloric acid. When all of the iron is reduced, add 30 c.cm. of sulphuric acid (1 : 2), and as soon as all of the zinc is dissolved and the solution is cool, titrate with potassium permanganate.

For the determination of manganese use 50 c.cm., evaporate to a very small bulk, add strong nitric acid and evaporate the hydrochloric acid; add 75 c.cm. of strong nitric acid, which should be free from nitrous acid, and 5 grammes of potassium chlorate, heat to boiling, and boil fifteen minutes; then add 50 c.cm. of nitric acid and more potassium chlorate. Boil until yellow fumes cease to come off, cool in ice-water, filter on asbestos, and wash with colorless, strong nitric acid; suck dry and wash out the remaining nitric acid with water, transfer the precipitate and the asbestos to a beaker, add a measured excess of standard solution of ferrous sulphate in dilute sulphuric acid, stir until all of the manganese dioxide is dissolved, and titrate the remaining ferrous sulphate with potassium permanganate. A ferrous solution of about the proper strength is made by dissolving 10 grammes of crystallized ferrous sulphate in 900 c.cm. of water and 100 c.cm. of sulphuric acid (specific gravity 1.84). This solution is titrated with standard potassium permanganate. The reaction taking place when the manganese dioxide acts on the ferrous sulphate is $\text{MnO}_2 + 2\text{FeSO}_4 + 2\text{H}_2\text{SO}_4 + \text{MnSO}_4 + \text{Fe}_2(\text{SO}_4)_3 + \text{H}_2\text{O}$. Hence the iron value of permanganate multiplied by 0.491 gives the value in manganese.

3. *Blue Pigments*.—There are two important blue pigments used in painting, Prussian blue and ultramarine. Of minor importance and very little used in paints for anything but artists' colors are cobalt blue and smalt.

(a) *Prussian Blue*.—Under the name Prussian blue are included all ferrocyanide blues such as Antwerp blue, Chinese blue, Turnbull's blue, etc. These blues are all ferric ferrocyanides, ferrous ferricyanides, or double iron potassium salts of hydroferrocyanic or hydroferricyanic acids. The analysis of these blues, as is generally the case

with pigments, does not necessarily give results which can be used to grade samples, the strength and color tests being most important. Most text-books say that Prussian blue is ferric ferrocyanide, $\text{Fe}_4[\text{Fe}(\text{CN})_6]_3$, but this substance is not known commercially. Commercial Prussian blue is a mixture of Williamson's blue, $\text{KFe}[\text{Fe}(\text{CN})_6]$, with other iron-alkali cyanides and often with aluminium-iron cyanides, altogether a most complex substance.*

(1) Moisture.—For the determination of moisture dry 2 grammes for two hours at 100°C . Dry blue should contain less than 7 per cent of moisture.

(2) Insoluble Impurities.—Ignite 1 gramme in a porcelain dish at a low temperature. The ignition should be carefully carried out at a temperature just high enough to decompose the last trace of blue, but not high enough to render the iron insoluble or very difficultly soluble in hydrochloric acid. Cool, add 15 c.cm. of hydrochloric acid, digest for an hour on the steam-bath covered with a watch-glass, evaporate to a syrup, add water, boil, filter from the insoluble, wash, ignite, weigh, and determine the nature of the insoluble, probably barium sulphate. In pure Prussian blue solution should be complete.

(3) Total Iron.—Decompose as in the foregoing determination, reduce, and determine the iron in the ordinary way. There should not be less than 30 per cent, calculated on the dry pigment.

(4) Total Nitrogen.—Determine on a 1-gramme sample by the official Gunning method, digesting for three hours.† The percentage of Prussian blue may be obtained with sufficient accuracy for commercial purposes by multiplying the percentage of nitrogen by 4.4 and by multiplying the percentage of iron by 3.03. Eight samples of pure Prussian blue examined by Parry and Coste gave the mean results from which these factors are calculated. The following table shows the accuracy with which these factors give the percentage of Prussian blue in the eight samples:

* Parry and Coste, *The Analyst*, 1896, xxi., 225-230.

† U. S. Dept. Agr., Bureau of Chemistry, Bul. 107, Revised, p. 7.

PARRY AND COSTE'S DETERMINATION OF THE PERCENTAGE OF PRUSSIAN BLUE IN THE DRY MATTER OF EIGHT SAMPLES

Factors.	No. 1.	No. 2.	No. 3.	No. 4.	No. 5.	No. 6.	No. 7.	No. 8.
Nitrogen $\times 4.4$.	94.69	100.93	107.58	94.91	98.95	99.83	100.80	102.52
Iron $\times 3.03$	94.63	101.02	109.71	97.11	94.84	98.99	102.47	100.26

(5) Other Determinations.—It is seldom worth while to make any further determinations. If desired, however, the iron and aluminium may be precipitated as hydrates by ammonium hydroxide and weighed together as oxides, and the aluminium obtained by difference after determining the iron volumetrically and calculating to ferric oxide. The filtrate from the iron oxide and alumina precipitate may be made up to a definite volume and one aliquot taken for the determination of sulphate and another evaporated with sulphuric acid, ignited, and weighed. Determine whether the alkali is sodium or potassium and subtract the alkali metal corresponding to the sulphate (SO_4) found. The remainder is double alkali iron ferrocyanide. Well-washed blues should be neutral in reaction. The red shade may be due to organic red. Test the solubility in alcohol, etc.

(b) Ultramarine.—Ultramarine is a compound of unknown constitution made by heating clay, soda, sulphur, and charcoal together. It appears to be complex silicate and sulphide of aluminium and sodium. Ultramarine may be readily distinguished from Prussian blue by being dissolved in hydrochloric acid with the evolution of hydrogen sulphide. It cannot be mixed with lead pigments on account of the sulphide present. Good ultramarine gives little tarnish on polished copper. An analysis is of little value, but if desired may be conducted as follows:

(1) Moisture.—Dry 2 grammes for two hours at 105°C .

(2) Silica.—Treat 1 gramme with 20 c.cm. of hydrochloric acid (1 : 1) in a covered dish, heat until decomposed,

remove the cover and evaporate to dryness on a water-bath, moisten with hydrochloric acid and again heat to dryness, add 1 c.cm. of hydrochloric acid, let stand five minutes, add hot water, filter, and wash the insoluble. If great accuracy is desired, evaporate the filtrate to dryness, take up with hydrochloric acid and water, filter, and add the precipitate to the main insoluble. Ignite the insoluble, weigh as silicon dioxide, and test the purity with hydrofluoric acid.

(3) Aluminium.—Determine the aluminium in the filtrate from the silicon dioxide by precipitating with ammonium hydroxide, igniting, and weighing as aluminium oxide.

(4) Soda.—Add sulphuric acid to the filtrate from aluminium hydroxide, evaporate to dryness, ignite, and weigh as sodium sulphate (Na_2SO_4). Calculate to sodium monoxide (Na_2O). If calcium is present it should be precipitated with ammonium oxalate in the filtrate from aluminium hydroxide, ignited, and weighed as calcium oxide, and the soda determined in the filtrate from the calcium oxalate, as described previously.

(5) Sulphur.—Mix 1 gramme of ultramarine with 4 grammes of sodium carbonate and 4 grammes of sodium peroxide in a nickel crucible, cover with about a gramme of sodium carbonate, fuse, using an aluminium or asbestos shield to prevent the sulphur from being taken up from the gas. Dissolve the fused mass in water, making acid with hydrochloric acid; there is no insoluble residue. Precipitate with barium chloride and determine total sulphur by weighing the barium sulphate.

(6) Sulphur as Sulphate.—Weigh 1 gramme in a beaker, add water, then hydrochloric acid, boil until the hydrogen sulphide is expelled, then add barium chloride, and determine the sulphur as usual by weighing the barium sulphate.

(7) Sulphur as Sulphide.—Subtract sulphur as sulphate from the total sulphur. Pure ultramarine will generally have about the following composition:

	Per Cent
Silicon dioxide (SiO_2).....	39 to 43
Alumina (Al_2O_3).....	24 to 30
Sodium monoxide (Na_2O).....	17 to 21
Sulphur (S).....	10 to 16

4. *Green Pigments*.—The most important green pigment is chrome-green, which is a mixture of Prussian blue and lead chromate. A green made of ultramarine and zinc-yellow is occasionally encountered. If absolute permanence is required chromium oxide (Cr_2O_3) is sometimes used, but this pigment is not common. The very brilliant copper-arsenic compounds (Paris green, etc.) are little used in paints.*

(a) *Chrome-Green*.—(1) *General Discussion*: A pure chrome-green should contain only Prussian blue, lead chromate, and lead sulphate. Any other substances should be considered adulterants. Greens made by precipitating the ingredients together are superior to those made by mixing the blue and yellow after they are precipitated separately. To distinguish the two, rub up the pigment in oil and allow to stand. A badly made green will show blue, but one properly made by precipitation will not. A microscopic examination of the dry pigment should also be made. A badly made green will show yellow and blue particles, as well as green. A well-made green will show green and some blue particles, but no yellow.

As different grades of lead chromate vary greatly in shade, and as the same is true to a somewhat less extent with Prussian blue, actual determinations of the percentages of Prussian blue, lead chromate, and lead sulphate are of little real value, and the analysis of chrome-green is made with difficulty. It is, however, important to determine impurities, which may be barium sulphate, silica and silicates (clay), or calcium and magnesium compounds.

(2) *Impurities*.—To examine for impurities proceed as follows: Place 1 gramme in a small casserole, add 10 c.cm. of water and sodium peroxide, a little at a time (about 1 gramme in all), to oxidize the Prussian blue; add about 25 c.cm. more of water and boil for some time, so as to decompose all of the hydrogen peroxide. Acidify with hydrochloric acid, boil, filter, and wash. Transfer the residue again to the casserole and boil with a solution of

* For methods of analysis see U. S. Dept. Agr., Bureau of Chemistry, Bul. 107, Revised, pp. 25-30; also, Lunge, "Chemisch-technische Untersuchungsmethoden," ii. 807-810.

ammonium chloride (slightly alkaline) to dissolve the last trace of lead; filter, wash, ignite, weigh the insoluble impurities, and determine their nature. They are probably barytes or silica.

Heat another 1-gramme portion very gently in a casserole or small porcelain dish, and remove from the flame as soon as it begins to glow. The heating should be carried out very carefully, the object being to decompose the Prussian blue but not to heat it enough to render the iron difficultly soluble. Allow to cool, add hydrochloric acid, and digest covered on the steam-bath for an hour. As a general rule this treatment brings everything except insoluble impurities into solution. Cool, dilute to 300 c.cm., and pass in a rapid stream of hydrogen sulphide until all of the lead is precipitated; filter, wash with water containing some hydrogen sulphide, boil off the hydrogen sulphide from the filtrate, add bromine water to oxidize the iron, add ammonium hydroxide in slight excess, filter, dissolve the precipitate in hydrochloric acid, reprecipitate with ammonium hydroxide, filter, wash, unite the filtrates, and determine calcium and magnesium in the usual way.

(3) Quantitative Determination of Yellow and Blue.—The examination for impurities is usually sufficient, but if a quantitative determination of yellow and blue be desired, the sulphate may be determined in the united filtrate from the insoluble impurities by precipitating from hydrochloric acid with barium chloride. The ferric ferricyanide present will not cause any difficulty if the barium sulphate is filtered off soon after precipitating; but if it is allowed to stand a long time a reduction is likely to take place with the re-formation of some Prussian blue.

Determine the lead in the second portion by dissolving the lead sulphide in nitric acid, boiling the residues with ammonium acetate, uniting the filtrates, adding sulphuric acid, heating to fumes, and completing the determination of lead as sulphate in the usual manner. For iron and chromium dissolve the ammonia precipitate in hydrochloric acid, make up to definite volume, determine the iron in an aliquot by reduction and titration with potassium permanganate or potassium dichromate. Determine the

chromium in another aliquot as described under chrome-yellow.

(4) Miscellaneous Determinations.—If aluminium is present, precipitate another aliquot with ammonium hydroxide, wash, dry, ignite, and weigh. From the iron and chromium determinations calculate the combined weight of ferric oxide and chromium oxide and obtain aluminium oxide by difference. Determine the moisture and the nitrogen as described under Prussian blue.

If the presence of ultramarine is suspected, test with hydrochloric acid, and if hydrogen sulphide is evolved, ultramarine is present.

(b) Ultramarine and Zinc-yellow-green.—(1) General Discussion: No lead compounds should be in this green, since with lead and ultramarine the paint will soon be blackened by the formation of lead sulphide. Owing to the widely varying composition of ultramarine, it is not possible to make a quantitative determination of the blue, but its presence can be detected by means of hydrochloric acid, and the combined percentage of ultramarine and insoluble impurities thus be determined.

(2) Determination of Yellow.—Treat 1 gramme of the dry powder with 25 c.cm. strong ammonium hydroxide, stir well, and dilute to about 100 c.cm. with water. Stir frequently for about thirty minutes, carefully breaking up all lumps, but do not heat. Filter, wash with dilute ammonium hydroxide, and then with water; dry the residue at 105° C. to constant weight, and weigh. The loss in weight gives the amount of zinc-yellow if no other soluble compounds are present. The filtrate may be tested as in the examination of zinc-yellow.

(3) Ultramarine and Insoluble Impurities.—The insoluble material remaining from the determination of yellow (2) may contain both ultramarine and other insoluble substances, but its color strength can be determined as compared with a standard pure ultramarine, and the result calculated to percentage based on a standard ultramarine.

Mixed Paints.—Single pigments are generally sold either dry or ground in oil alone; rarely do they contain thinners or driers. Ready-mixed paints, however, contain, in

addition to oil, turpentine or gasoline and usually some drier. More complicated yet are enamel paints, which are pigments ground in oil-varnish, and contain, besides the substances in the vehicle of mixed paints, varnish-gums.

The can of mixed paint should not be shaken, but should be weighed as a whole, opened, and as much of the clear vehicle removed as possible; this should be weighed and kept in a stoppered flask (use cork, not rubber, stopper). After removing the clear vehicle mix the contents of the can thoroughly and transfer to another jar. Wipe and weigh the can. These figures will give the necessary data for calculating the analytical results back to the original material.

1. *Extraction of the Vehicle.*—Weigh from 15 to 35 grammes of the thoroughly mixed pigment in a tall, narrow Erlenmeyer flask of 300 c.cm. capacity. Add about 10 c.cm. of gasoline, mix thoroughly, then add 150 c.cm. of gasoline, mix well, and stopper with a cork; allow to stand until the pigment has settled, and decant the liquid into a beaker; some pigment will frequently go over with the gasoline, so it is well to allow this to settle and decant into a second beaker. Repeat the treatment with gasoline; after the first treatment settling is generally much more rapid. Decant the gasoline as completely as possible the second time. Then add 150 c.cm. of benzole (C_6H_6), shake, and allow to settle. Decant the benzole and treat in same way with 150 c.cm. of ether. (If a large number of samples are examined at the same time this method is as rapid as any; but when working with a small number of samples much time is saved by extracting in tubes and throwing down the pigment by whirling in a centrifuge.) This method of extraction is often more satisfactory than any method using a continuous extraction apparatus, for frequently the pigments cannot be held by extraction thimbles. This method of treatment will generally give an almost complete separation of the vehicle, but in some enamel paints it is well to follow the gasoline treatment by a treatment with turpentine, and then remove the turpentine with gasoline before treating with benzole and ether. Some paints are very difficult to settle when treated

with a single solvent, and mixtures of solvents must then be tried. Mannhardt ("Select Methods of Paint Analysis") recommends 60 volumes of benzole and 40 volumes of 95-per-cent wood alcohol. No system of extraction will remove absolutely all the vehicle, the insoluble portion being probably metallic soaps or linnoxyn.

After removing all of the soluble vehicle, dry the pigment, first at a low temperature in a gentle current of air, and then at 105° C.; weigh, and from the loss in weight calculate the percentage of vehicle and pigment; then from the total weight of mixed paint and the weight of clear vehicle drawn off calculate the percentage of vehicle and pigment in the original paint.

2. *Analysis of Pigment.*—Follow the methods for dry colors. In general, determine the amount insoluble in hydrochloric acid and the nature of the insoluble, and make an analysis of the soluble portion. In the absence of carbon and hydrated silicates (clay, etc.), a fairly close determination of unextracted vehicle may be made by drying the insoluble at 105° C., weighing, and then igniting and weighing. This loss is called combined water and carbonaceous matter, and in many cases may be safely considered as unextracted vehicle.

3. *Analysis of Vehicle.*—Weigh 100 grammes of the vehicle into a 500-c.cm. flask, connect with a spray-trap and a vertical condenser, and pass through it a current of steam, first heating the flask in an oil-bath at 100° C.; with the steam still passing through, raise the temperature of the bath to 130° . Catch the distillate in a small weighed separatory funnel; continue distillation until the funnel contains 300 c.cm. of water. Let the distillate stand until separated into two layers, then draw off the water and weigh the light oils. Examine as under turpentine, page 243. A slight error is caused by the solubility of turpentine in water; this amounts to about 0.3 to 0.4 c.cm. for each 100 c.cm. of water.

When sufficient vehicle is available it is well to take another portion and distil, without steam, placing the flask in an air-bath. Note the temperature of the bath at which distillation takes place, and continue the distilla-

tion at a temperature of 185° C. in the air-bath. This method gives somewhat lower results on volatile oils than the first method, but the distillate can be tested for water-soluble volatile liquids which would be lost by the steam distillation. Unsaponifiable matter should be determined in this residue, or in some of the original vehicle. (See examination of linseed-oil, p. 242.)

The residue is frequently too pasty for the determination of the specific gravity, which should be made on the original vehicle. Determine specific gravity with a plummet or hydrometer. The small amount of suspended pigment which frequently remains in the vehicle will introduce an error when a pycnometer is used. Determine the acid number of the residue and of the original vehicle. Determine the percentage and the character of the ash either from the residue or the original vehicle. The iodine number is sometimes a useful index; but the constants of linseed-oil which has been mixed with pigments, especially lead compounds, may be so much altered that an iodine number as low as 100 cannot be taken as any proof of the presence of other fatty oils.

Test for rosin as described under linseed-oil. Another test for rosin may be made by dissolving in carbon disulphide and adding a solution of stannic bromide or chloride in carbon disulphide. Use a white porcelain dish. If no water is present in either solution the presence of rosin is shown by the appearance of a violet color. This test is not as delicate as the Liebermann-Storch test described under linseed-oil.

When much lead is present it may be lost in ashing, and for a correct determination of metals the following method is best: Place 25 grammes of the vehicle in a 500-c.cm. separatory funnel, dilute with 25 c.cm. of a mixture of equal parts of gasoline and turpentine, add 50 c.cm. of nitric acid (1:1), and let stand one hour, shaking every ten minutes. Then immerse the funnel in hot water, loosen the stopper, and shake gently. This drives off nearly all the gasoline. Remove from the hot water, let it separate, draw off the lower layer, and wash the upper oily layer four or five times with warm water. Add the wash-

ings to the main acid portion and determine the metals in the ordinary manner. If the paint is enamel paint, treat the vehicle as a varnish. (See p. 249.)

ANALYSIS OF SHELLAC BY SOLVENTS—MCILHINEY

The method depends upon the fact that rosin is soluble in petrolic ether while shellac is insoluble. It is impracticable to effect an extraction of the rosin from the solid mixture; therefore the latter is dissolved in a solvent such as absolute alcohol or glacial acetic acid (99 per cent), which dissolve both shellac and rosin and which are themselves miscible both with petrolic ether and with water. Petrolic ether, boiling below 80° C., is added, then water, and the resulting two layers of immiscible liquids separated, the petrolic-ether layer carrying the rosin with it and leaving behind the shellac, which is largely precipitated by the dilution with water. The wax usually goes with the rosin unless the amount of petrolic ether is insufficient; shellac-wax is but slightly soluble in cold petrolic ether, but the amount of shellac-wax present is usually small. The amount of rosin recovered from the petrolic-ether solution is determined by titration with alkali or better by separation from the unsaponifiable wax. Both wax and rosin may be weighed. The amount of shellac dissolved by the petrolic ether is less than 1 per cent. This material is essentially different from common rosin. The original paper is in the *Journal of the Am. Chemical Society*, xxx. 867, May, 1908.

ANALYSIS OF OLEO-RESINOUS VARNISHES—MCILHINEY

Saponify a weighed amount of the varnish with an excess of a solution of caustic potash or soda in absolute alcohol, then add just sufficient of a solution of pure acetic acid in absolute alcohol to exactly neutralize all the alkali added, adding to the acidified liquid petrolic ether, which mixes freely with it, then adding, with stirring, sufficient water to greatly dilute the alcohol, and separating the petrolic-ether solution containing in it the fatty acids of saponified oil and the common rosin. The hard gum

(resin), together with some oxidized fatty acids, remains insoluble. The oxidized fatty acids are separated from the hard gum by their solubility in slightly diluted alcohol. The common rosin is separated from the fatty acids of linseed and other oils by the Twitchell process. The Koettstorfer figure is obtained in the original saponification process by making use of standardized solutions of alcoholic acid and alkali. Volatile oils are separated by distillation with steam in the ordinary way, and benzine and turpentine are tested for, and determined by the processes commonly in use.

The original paper is in the proceedings for 1908 of the Am. Soc. for Testing Materials, and is also in the *Chemical Engineer* for August, 1908, viii. 70.

Analysis of Shellac.—W. Vaubel, *Ch. Ztg.*, xxxiv. 991, 1008. Storch-Morowski test for rosin, dissolve in ac. anhyd., add drop H_2SO_4 , red-violet color. Langmuir's bleaching test, *J. S. C. I.*, 1905, p. 14—I number by Wijs solution, using colorimetric scale. Quantit. det. by dissolv. rosin out with $CHCl_3$, CCl_4 , or benzole, and test solution and residue; or dissolve out shellac in $Na_2B_4O_7$ solution, 10 grammes in 200 c.cm. 10-per-cent solution on water-bath. Acid and saponification numbers:

Name of Resin.	Analyst.	Acid No.	Sapon. No.	Ester No.
1. Dark shellac	Lewkowitsch.	61.13	203.0	141.8
2. Stick-lac	Rudling	39.2- 56.0	212.8-260.1	170.8-212.8
3. Seed-lac	"	53.0- 61.1	218.4-251.9	165.4-190.7
4. Button-lac	"	58.8- 64.0	204.4-215.3	145.6-153.4
5. Average of 11 samples.	Umney	44.0- 70.0	166.0-235.0	122.0-167.0
6. Colophony	Lewkowitsch.	146.0	153.0	6.55
7. White French rosin	Rudling	169.7-171.2	177.8-179.4	8.1- 8.2
8. American rosin	"	157.0-159.4	182.0-183.8	24.1- 24.4
9. Pine resin	Dietrich	100.0-160.0	150.0-190.0	10.0- 30.0

This table shows it is impossible thus to detect 20 per cent adulteration.

I is absorbed but little, probably is taken by resin-like terpene derivatives. Bleached shellac has already taken up some Cl. Possibly wax may affect the I absorption. Langmuir prefers Wijs solution which does not discolor if rosin is absent; Rudling uses Hübl's solution. C. Ahrens

finds I number for rosin 110-165 with Hübl's solution in 6 hours, which is too short a period. The per cent of adulteration will be shown as variable, according to what I number is taken for rosin, especially in poor grades. Wide variations are found in Br. numbers by different analysts. A method is given for finding Br. number, which involves separatory solutions by different solvents.

The I number is as follows:

Name of Resin.	Analyst.	METHOD.		
		I Cl.	Br.	Hübl Sol.
Dark shellac.	Lewkowitsch.	35.57	13.25
Stick-lac.	Rudling.	8.0- 19.5
Seed-lac.	"	3.6- 8.6
Button-lac.	"	19.0- 23.2
Pure shellac.	Langmuir.	18.0
Bleached shellac.	"	8.0
Seed-lac (inferior).	Umney.	23.0
Seed-lac (good).	"	8.0
Stick-lac.	"	14.6
Button-lac (Bagoc).	"	23.6
Button-lac.	"	33.2
Orange shellac T N.	"	12.5
Colophony.	Lewkowitsch.	133.7	302.1
White French rosin.	Rudling.	137.1-138.3
American rosin.	"	122.0-123.2

Analytical Constants of Shellac.—P. Singh, *J. Soc. C. I.*, xxix. 1435. Samples of known purity give results as follows:

	1	2	3	4	5	6	7
Moisture (expelled at 100°)							
per cent	2.7	3.8	3.9	2.0
Matter insoluble in hot alcohol,							
per cent	0.7	0.8	1.1	0.6
Acid number (A)	61.1	60.8	63.1	64.4	22.1-24.3	52.1- 59.2	54.9
Saponification number (B)	201.0	202.4	201.6	203.6	79.2-85.0	193.5-198.4	190.0
Ester number (B-A)	139.9	141.6	138.5	139.2	57.1-60.7	139.2-141.4	135.1
I absorption number (Hübl)							
after 18 hours' action	9.6	9.3	8.2	8.6	8.8	6.8- 7.3	5.9
Endmann number	8.4	8.0	9.2	7.4	7.3- 8.1

1. Shellac from Kusum-lac. 2. Shellac from Palas-lac. 3. Shellac from block-lac. 4. Mirzapur factory shellac. 5. Lac-wax (m. 58°-59°). 6. Lac-resin (desiccator dry). 7. Lac-resin (melted).

The "Endemann number" is per cent of non-condensable resin and fatty acids; to obtain this, mix 2 grammes of shellac with $\frac{3}{4}$ gramme precipitated SiO_2 , which previously has been calcined 12 hours at white heat, moisten with $\text{C}_2\text{H}_6\text{O}$, dry 2 hours at 100° – 105° , moisten with $\text{C}_2\text{H}_6\text{O}$, add 10 c.cm. concentrated HCl , evaporate to dryness, repeat $\text{C}_2\text{H}_6\text{O} + \text{HCl}$ treatment, dry at 105° , extract with 160 c.cm. $\text{C}_2\text{H}_6\text{O}$ in 20-c.cm. portions, filter the extract, evaporate to dryness, and weigh. It should not exceed 8.0 in standard good qualities of shellac, is higher in black lac. Discussion of the foregoing: E. J. Parry.—"T. N." shellac may legitimately contain 3 per cent rosin, garnet 10 per cent. Vaubel's recent table is from adulterated shellac, not correct. Ester and acid values not reliable, as lac-dye interferes with phenolphthalein indicator. "Endemann number" useless, does not show adulteration unless excessive. I number only test of value; Hübl preferred, as Langmuir's method with Wijs solution is too complicated. Vaubel dissolves out lac-resin in borax solution, but this leaves wax, etc., to be estimated as rosin. McIlhiney dissolves out rosin with petroleum ether, but the shellac forms a protective coating on the rosin. J. Lewkowitsch.—The "Endemann number" and Ester value are useless; prefers Wijs solution to Hübl, because it is more rapid. Rosin I number 125, agreed on in the London market, is arbitrary but conventional. E. G. Hooper.—Prefers Wijs solution, but difference in I value from the Hübl method should be recognized; recommends investigation of advantages of these methods. In mixtures like sealing-wax the insolubility (93 per cent) of shellac in benzole affords a means of separating it from rosin.

Analysis of Shellac.—Dr. H. Wolff, *Farben. Ztg.*, xv. No. 50; through *Rev. Fett-Harz-Ind.*, xvii. 243. Qualitative test for resin: dissolve a few grains of the shellac in 3 c.cm. alcohol; when solution is complete add 3 c.cm. benzine (b. 100° – 150°) and shake well; then fill test-tube with H_2O and mix gently (without shaking). Allow the benzine to clarify and pour it into a second test-tube, add to it a few drops of a 3-per-cent solution copper acetate and shake well. Allow to settle clear, aiding it by addition of H_2O if neces-

"PROPERTIES OF DIFFERENT VARIETIES OF DAMMAR RESIN" (C. Coffignier,
Bull. Soc. Chim., ix. 549-61: includes some sandarac and mastic figures)

RESIDUES INSOLUBLE IN	Sumatra.	Padang from Sumatra.	Borneo.	Pontinjak from Borneo.	Singapore.	Batavia.	Batjan from Molucca Islands.	Sandarac.	Mastic.
EtOH.....	45.5	20.3	23.6	22.4	19.1	32.8
MeOH.....	52.2	53.0	31.9	29.4	24.6	34.3	40.0	35.8	12.5
Amyl alcohol.....	34.2	7.6	12.2	3.7	5.8	10.9
EtO.....	37.9	4.5	9.6	4.1	1.0	3.2
CHCl ₃	13.1	0	7.4	0	0	3.6
Benzene.....	18.3	0	7.5	0	0	3.1
Acetone.....	45.3	14.7	20.4	16.4	14.0	16.5	21.3	17.8	9.3
Spirit of Turpentine...	12.6	0	4.6	0	0	2.7
Benzoic aldehyde.....	24.7	0	8.0	0	0	0	0	18.2	0
Aniline.....	32.8	0	16.0	0	0	0	0	0	6.1
Amyl acetate.....	30.0	6.2	10.1	4.6	4.1	7.3
CCl ₄	31.6	0	8.4	0	2.5	11.4

"STUDY OF DAMMAR" published by Coffignier, *Rev. chim. ind.*, xix. 319, but name of author not given: all were quite soluble in spirit of turpentine).

VARIETY OF DAMMAR.	Character of Varnish Film.	Character of Resin.	Color.	SOLUBILITY IN		Melting-point.	Ash, per Cent.	Saponification Number.	Acid Number.
				Alcohol.	Ether.				
Perak	Friable	Clear, pale yellow	Partly.	Quite.	90°	0.26	46.7	45.3
Mata Kuching	Hard, brilliant, colorless.	Oval drops, hard.	Pale yellow, transparent.	Nearly.	Quite.	87°	0.05	38.5	38.5
Songyi	Soft and dark.	Irregular, hard.	Dark brown	Partly.	Partly.	180°	0.52	34.3	33.0
Meranti	Dull and sticky.	Friable	Opaque, yellowish-white.	Partly.	Partly.	185°	0.03	72.0	72.0
Mata Kuching de Jempol	Hard, brilliant, colorless.	Hard	Clear, colorless	Partly.	Quite.	92°	0.06	33.0	33.0
Kumus	Reddish-brown, translucent.	Partly.	Quite.	94°	0.08	72.0	72.0
Rengkong	Hard, not brilliant.	Yellowish-brown	Partly.	Partly.	200°	0.04	46.7	46.5
Merawan	Hard, clear, brilliant.	Oval drops.	Yellowish-white, translucent.	Partly.	Quite.	97°	0.25	38.5	38.5
Strayah	Hard, not brilliant.	Yellowish-brown	Partly.	Partly.	190°	0.09	55.0	55.0

sary. If rosin is present the benzine solution turns bluish-green.

Quantitative test for rosin: Add in a separatory funnel 3 grammes of the powdered shellac to 30 c.cm. of a mixture containing 65 per cent by volume of acetone, 20 per cent of alcohol (96 per cent), and 15 per cent H_2O ; if much rosin is present use 5 per cent more acetone and 5 per cent less alcohol. When solution is complete (shellac-wax remains insoluble) add 25 c.cm. petroleum ether and shake well. Allow to settle and draw the lower layer into a second funnel and shake it again with 25 c.cm. petroleum ether. Unite the petroleum-ether extracts and evaporate dry. Dissolve the residue in 9 c.cm. petroleum ether and 1 c.cm. ether, filter if necessary into a weighed dish, and evaporate at 105° - 110° to constant weight. If x is the weight of the residue then per cent rosin equals $(100 \times 3 - 1.0) F$, where F has the following values:

1-10 per cent rosin, 1.25; 10-15 per cent rosin, 1.30; 15-20 per cent rosin, 1.35; 20-25 per cent rosin, 1.30; 25-30 per cent rosin, 1.25; 30 and over, 1.20.

After weighing dissolve the residue in 96-per-cent alcohol. No flocks should remain undissolved. If turbid, filter again, evaporate, dry, and weigh. If y is the second weight of the residue the per cent rosin equals $(100 y/3 - 0.5) F$, the factor F having the same values as above. The limits of error are ± 2 per cent.

Detection of Dammar in Kauri Resin.—S. Stewart, *J. Soc. Chem. Ind.*, xxviii. 348. Solutions in chloroform containing dammar give a white precipitate when absolute alcohol is added. Pieces of resin may be tested by rubbing with a drop of chloroform on a glass plate, then add a drop of alcohol. Solutions containing small amounts of dammar may be made milky by adding alcohol and compared with similar solutions of known composition.

The following review of work in 1908-09 is by Coffignier, in his journal, the *Rev. chim. ind.*, xxi. 265-75.

Engel has examined Congo and Benguela copals and has found that when treated with solvents they leave insoluble residues, as follows:

Solvents.	Congo Melts at 105° to 185°.	Benguela Melts at 106° to 158°.
Ether.....	45%	48%
Ethyl alcohol.....	52	44
Methyl alcohol.....	67	72
Acetone.....	72	64
Amyl alcohol.....	20	28
CHCl ₃	76	65
Benzole.....	74	76

From Congo he obtained congoopalic acid, C₁₉H₃₀O₂, and congoopalolic acid, C₂₂H₃₄O₃, and α -congoopaloresene and β -congoopaloresene. Benguela gives similar products; the benguecopalolic acid is C₂₁H₃₂O₃. African elemi (*Ann. Chim. Analyt.*, 1909, 194) is similar to Manila elemi, but has less volatile oil. South Nigerian elemi (A and B) is little soluble in alcohol but soluble in oil of turpentine and in benzole. The volatile oil is pale-yellow, contains much phellandrene; $D = 0.8686$; $\frac{\alpha}{D} = 50^{\circ} 30'$. Uganda elemi is soluble in benzole, little in alcohol, and partly in turpentine, but soluble in benzole-alcohol mixture, also in turpentine-alcohol. Its volatile oil is like the preceding, $D = 0.8451$, $\frac{\alpha}{D} = +79^{\circ} 20'$.

Elemi.	A	B	C
Ash.....	0.60	0.53	0.30
Acid number.....	55.3	37.8	29.4
Koettstorfer number.....	71.9	46.3	44.8
Volatile oil.....	8.1	4.4	11.2

Distilling red angola does not give succinic acid. The solution in ether (69 per cent soluble) gives, with a weak solution of Na₂CO₃, a mixture of two acids which Rackwitz (*Bull. Soc. Chim.*, xi. (1909) 135) separated by an alcohol solution of acetate of lead into (1) angocopalic acid, C₂₃H₃₆O₃, unsaturated, monobasic, melts 85°, lead salt insoluble; (2)

an impure acid of which the lead salt is soluble; in the solution from which these have been removed there is an essential oil, $D = 0.853$, $b. 140^{\circ}-160^{\circ}$, and α -angocopaloresene, $C_{30}H_{54}O_6$, dark yellow, $m. 63^{\circ}-65^{\circ}$. In the ether-insoluble residue is found angocopalolic acid and β -angocopaloresene, $C_{25}H_{38}O_4$, $m. 220^{\circ}-224^{\circ}$. Similar work on Cameroon copal shows absence of succinic acid, and produces camerooncopalaic acid, $C_{21}H_{36}O_3$, monobasic, unsaturated, $m. 98^{\circ}-100^{\circ}$, and volatile oil, $D = 0.830$, $b. 145^{\circ}-155^{\circ}$; and α and β camerooncopaloresenes, the second $C_{25}H_{38}O_4$, $m. 225^{\circ}$. Coffignier's work on copals is in *C. A.*, ii. 1895, and iv. 679.

By treating the ether solution of sandarac with 1 per cent $(NH_4)_2CO_3$ solution, Tschirch and Wolff (*Bull. Soc. Chim.*, ii. (1908) 1638) obtained sandaracic acid, $C_{22}H_{34}O_3$, $C_{22}H_{36}O_3$, or $C_{22}H_{38}O_3$, $m. 186^{\circ}-188^{\circ}$, inactive, forming a monopotassic salt; by treating the ether solution with 1 per cent Na_2CO_3 , sandaracinolic acid, $C_{24}H_{36}O_3$, which forms an insoluble Pb salt; acid inactive, forms monopotassic salt; and also sandaracopimaric acid, $C_{19}H_{28}O_2$, $C_{20}H_{30}O_2$, or $C_{20}H_{32}O_2$, needles $m. 170^{\circ}$, inactive, forms monopotassic salt, and a soluble lead salt. After removing the resin acids, the residue distilled with steam gives a volatile oil, $b. 152^{\circ}-159^{\circ}$, and a resene remains.

Guignes (*Bull. Soc. Chim.*, i. (1908) 872) gives the rotary power of colophony, $+6^{\circ}$ to $+7^{\circ}$, ordinary sandarac, $+46^{\circ} 20'$, ditto pure, $+31^{\circ}$ to $+34^{\circ}$; recent mastic, $+29^{\circ} 30'$, ditto second quality $+21^{\circ} 50'$. When elemi is melted in a water-bath and the yellow-green liquid treated with H_2SO_4 in four volumes H_2O , an eosine-red color is produced. Alcoholic solution of elemi is neutral to litmus which reddens a similar solution of turpentine. The alcohol solution of elemi gives a milky cloud when H_2O is added; with turpentine resinous yellow-brown flocks separate (Stoepel, *Jour. Phar. Chim.*, xi. (1908) 116). To detect rosin in shellac, Foerster (*Ann. Chim. Analyt.* (1909), 18) uses Halphen's reagent, as follows: grind 2 grammes shellac with sand in a mortar, add it to 10-15 c.cm. ether, agitate 5-10 minutes, filter, evaporate, put the residue in a capsule of 25-50 c.cm. capacity, add a little of Halphen's reagent

(1 volume carbolic acid, 2 volumes CCl_4), expose it to the vapor of 1 volume Br in 4 volumes CCl_4 ; a fine blue color appears, passing into violet. J. Sans (*Ann. Chim. Analyt.* (1909), 140) detects rosin more simply; 1 or 2 c.cm. neutral methyl sulphate is put in a test-tube, and a bit of rosin added. Heat gently; rose color passing to violet and dark violet; with more heat the color disappears, all but a faint brown.

Grimaldi (*Jour. Phar. Chim.*, i. (1908) 394) detects rosin-spirit in oil of turpentine. Put 100 grammes of the suspected oil of turpentine in a flask 8 cm. diameter having a neck 10 cm. long, with a side-tube connected with a condenser, and thermometer through stopper and in liquid. Distil slowly, collect five fractions of 3 c.cm. each, then fractions every 5° to 170° . To each fraction add an equal volume concentrated HCl and a small fragment of Sn. Put in a boiling water-bath five minutes, agitate, and put back in water-bath and repeat several times. Pure oil of turpentine gives emerald-green increasing in intensity on cooling. Rosin-spirit gives a faint color and only on cooling.

Accra and Benin γ -Copals.—A. Tschirch and Kahan, *Arch. Pharm.*, ccxlviii. 433. From Accra copal the following acids, soluble in ether, were obtained: accracopallic, $\text{C}_{21}\text{H}_{34}\text{O}_3$, melting-point 104° – 106° C.; α -accracopallic, $\text{C}_{18}\text{H}_{30}\text{O}_2$, m.-p. 152° – 155° ; β -accracopallic, $\text{C}_{19}\text{H}_{32}\text{O}_2$, m.-p. 144° – 148° ; α -accracopalenic, $\text{C}_{10}\text{H}_{20}\text{O}_2$, m.-p. 142° – 146° ; β -accracopalenic, $\text{C}_{12}\text{H}_{20}\text{O}_3$, m.-p. 150° – 152° ; α -accracopal resin, $\text{C}_{15}\text{H}_{36}\text{O}_6$, m.-p. 178° – 180° ; and an essential oil. The following were insoluble in ether: accracopalinic acid, $\text{C}_{14}\text{H}_{26}\text{O}_3$, m.-p. 122° – 124° ; γ -accracopal resin, $\text{C}_{10}\text{H}_{20}\text{O}_3$, m.-p. 184° – 186° ; β -accracopal resin, $\text{C}_{13}\text{H}_{26}\text{O}_3$, m.-p. 197° – 199° . Accra copal melts from 106° to 156° , acid number 121.8, iodine 58.54. Benin copal was extracted first with ether and then with ether-alcohol. The ether solution on the treatment with $(\text{NH}_4)_2\text{CO}_3$ yielded benincopallic acid, $\text{C}_{17}\text{H}_{32}\text{O}_4$, m.-p. 137° . On treatment with Na_2CO_3 it yielded α - and β -benincopallic acids, $\text{C}_{13}\text{H}_{32}\text{O}_6$ and $\text{C}_{20}\text{H}_{30}\text{O}_2$, m.-p. 81° and 119° . On treatment with KOH benincopalenic acid, $\text{C}_{27}\text{H}_{48}\text{O}_2$, m.-p. 101° , was obtained. An essential oil was also present in this portion. The ether-alcohol extract

contained α -benincopalinic acid, $C_{21}H_{30}O_3$, m.-p. 187° ; β -benincopalinic acid, $C_{15}H_{28}O_3$, m.-p. 193° - 197° ; β -benincopal resin, $C_{12}H_{30}O_{10}$; and γ -benincopal resin, $C_{13}H_{26}O_4$, m.-p. 192° - 195° . About 50 per cent of benin copal is soluble in ether and 98 per cent in ether alcohol; melts 166° , acid number 101.15, iodine number 61.02.

Two new South American copals are reported from French Guiana; one is a Guibourtia copal from Koulikoro, not pure enough to be valuable; the other a Trachylobium copal from Dubreka, much like Benguela copal, but softer; should be of commercial value.

H. Rackwitz (*Arch. Pharm.*, ccxlv. 415) finds that of Angola copal 69 per cent is soluble in ether, the solution containing 64 per cent of angocopalolic acid, $C_{23}H_{36}O_3$, which melts at 83° - 85° ; 3 per cent of α -angocopaloresene, $C_{30}H_{54}O_4$, melts at 63° - 65° ; and 2 per cent of ethereal oil, boils at 140° - 160° . The part insoluble in ether consisted of a portion soluble in ether alcohol, being an acid, apparently angocopalolic, 5 per cent and β -angocopaloresene, melts at 220° , 20 per cent; and insoluble in ether alcohol, 0.3 per cent of a bassorin-like substance, and 5.7 per cent ash. Similar treatment of Cameroon copal gave 75 per cent soluble in ether, consisting of kamerucopalolic acid, $C_{21}H_{36}O_3$, melts at 98° - 100° , 70 per cent; a kamerucopaloresene, 3 per cent, and ethereal oil, boiling at 145° - 155° , 2 per cent. The part insoluble in ether, 25 per cent, contained a portion soluble in ether alcohol, β -kamerucopaloresene, $C_{25}H_{38}O_4$, melts at 225° , 20 per cent; and insoluble in ether alcohol, a bassorin-like substance, 3 per cent; and ash, 2 per cent.

L. E. Andès in *Chem. Rev. Fett-Harz-Ind.*, xiv. 190, says that mastic resin is obtained from the trees of *Pistacia cabulica*, the bark of which is incised from the ground to the branches, and the resin allowed to harden and fall to the ground upon stone plates. After 2 to 3 weeks it is sufficiently hard to collect. The best mastic is taken from the branches, three grades being obtained. The gathering lasts for two months, and each tree yields 4 to 5 kg. Unger has made a thorough study of this mastic and also that from *Pistacia lentiscus*, and states that it is formed in special passages or intracellular spaces. He also says that the resin is not

produced from cell wounds by a chemical metamorphosis. The dropping of bark-scales is sufficient to cause a rupture of the resin passages, which lie close to the surface. The color of the resin is yellowish or greenish, and it possesses the odor and taste of carrots. According to Pfoff its density is 1.04, according to Schrotter and Brisson it is 1.07. Upon chewing it becomes doughy, while most other resins become pulverulent. According to Johnstone it melts at 100°, while Schrotter says it softens at 80° and melts with decomposition at 105° to 120°. It consists of an alcohol-soluble substance and one insoluble in alcohol, the latter being insoluble in ether and in turpentine. The resin acids have the formula $C_{40}H_{64}O_4$, and compose from 80 to 91 per cent of the resin.

M. A. Dubosc, in the *Bull. Soc. Ind. Rouen*, xxxiv. 373, says that Madagascar copal is found along the seashore, like amber, which it much resembles in appearance, being reddish-yellow to pale-yellow, difficult to break, clear and brilliant fracture, worn surface like pebbles. Specific gravity 1.054; melts 327°; softens 105°; acidity 78.5. Percentages insoluble in: cold alcohol, 90; hot alcohol, 72; ether, cold 84, hot 60; methyl alcohol, cold 87, hot 63; benzene, cold 89, hot 76; acetone, cold 82, hot 60; amyl alcohol, cold 50; aniline, cold 20; benzoic aldehyde, cold 16; carbon tetrachloride, cold 80; turpentine, cold 60; amyl acetate, cold 20.

A. Foelsing, *Chem. Rev. Fett-Harz-Ind.*, xiv. 251, says of East African copal that the copal-yielding trees are tall and resemble an old ash in growth. All parts of the tree yield copal-resin, a sticky stringy sap which hardens upon exposure to the air. This copal is not as valuable as that which has been fossilized underground and which originated from the roots of the copal trees. It is found at depths of 30 cm. to 1 metre, though not in large quantities, and is not dug to any great extent by the natives on account of the hard labor involved. Most of it comes from Dutch East Africa and is falsely called Zanzibar or East Indian copal. The fruit of the Zanzibar copal has 15 per cent copal in the shell and 8 per cent in the kernel, and when ripe it falls from the tree and can be gathered in large

quantities. This copal has all the good qualities of the purified copal obtained from the ground and is cheaper.

Demarara copal comes from British Guiana, in South America, and is in elongated pieces, glossy, dull, or mammillated; color pale-yellow to reddish; very hard, difficult to powder, fracture clear, brilliant. Powdered, it gives a characteristic odor as of valeric acid, which disappears gradually. Columbian copal, from South America, contains much dirt and débris; some pieces yellowish-white, some dark-yellow to reddish-brown, some of it is milky. Some of it has a crust several millimetres thick. It pulverizes easily, breaks easily, vitreous fracture; rather soft. Brazilian resin is white, yellow, yellowish-red; surface polished, rarely papillated; fracture clean, vitreous, brilliant; rather soft, easily powdered.

Benguela copal is from equatorial Guinea, south of Angola, on the west coast. The pieces are flat or rounded, color white to clear yellow. The crude copal is very dirty but cleans easily and the commercial resin is very pure. The surface is shining and brilliant; it is difficult to break and the fracture is brilliant. White and red angola are from that part of equatorial Guinea called Angola, on the Atlantic coast. The white is a resin of medium quality, the red is excellent. The white is found in rounded pieces, some very small, others medium and large, clean, white or pale yellow, hard, fracture brilliant; it is easily pulverized to a white powder. Red Angola is in irregular pieces, yellow and red, easily broken, difficult to pulverize to a yellow powder; surface sometimes papillated more coarsely than Zanzibar. It is found buried in the earth, sometimes as much as 12 feet. Congo resins are from the sandy interior regions of West Africa, north of Angola; are red, yellow to white, in large pieces more or less irregular in shape, clean surface, conchoidal fracture, very shining. Similar copals also come from Loango. Belgian Congo resin is the best, the French being very white but too soft for ordinary use. The data given are for the Belgian resin. Sierra Leone resin is from the British colony of that name in West Africa; it is not fossil, but is produced by a leguminous tree called *Guibourtia copallifera*, and is collected

as is turpentine in France. The pieces are irregularly spherical or elongated, usually small, containing impurities, yellowish to clear white, difficult to break, fracture brilliant, easily powdered.

Manila resin comes from Singapore, from Borneo, and from Celebes. There are three qualities, hard, semi-hard, and soft. The best hard resin comes from Borneo, the less valuable from Macassar, a city of Celebes. The pieces are large; white, yellow, red, brown; break easily; the best have brilliant fracture; some are milky within; aromatic odor. Soft Manila is white, red, clear brown; breaks easily, fracture brilliant, but often sticky; aromatic odor. Pontianak is from the city of that name, which is on the equator, on the west coast of Borneo. It resembles semi-hard Manila, and is practically the same thing. Odor aromatic, suggesting elemi. The data for hard Manila show large variations in the resin.

Solubility of kauri copal.—Trials were made on good samples of resin, of four grades: hard white or pale kauri, occurring in large pieces (to 100 kg.), color yellowish-white to pale-yellow, aromatic, fracture easy, brilliant, powders easily; brown, hard pieces variable in size, rough, hard to pulverize, color yellow-brown to dark-brown; the best pieces break with difficulty, conchoidal fracture; others break and pulverize easily; a faint aromatic odor, suggestive of camphor, is developed in pulverizing. The best hard pieces have specific gravity (at 9°) = 1.079. Bush kauri, which is collected at the foot of the tree, more recent in origin than either of the preceding, pieces irregular, reddish-yellow, brilliant fracture, easily reduced to yellowish powder with aromatic odor, pieces soft and with cavities. Bush-gathered, collected from the trunk of the tree itself, most recent, pieces regular, all sizes, yellowish-white, vitreous fracture, powders easily; odor faintly aromatic, does not gain by pulverization. The well-marked solubility in alcohol of pale kauri is contrary to general belief, but was carefully verified, only 6.6 to 7 per cent being insoluble. The general opinion that brown hard kauri is harder than pale is confirmed by its behavior to solvents.

Madagascar copals are of several sorts. From the prov-

ince of Tarafanga (east side) there are two: first quality, smooth yellow pieces, no incrustation, some dirt within, resin of excellent quality; second quality, resin inferior, small pieces, incrustated, dirty, milky, loses appreciably in washing, must be washed and sorted. Province of Mananyary (east side): pieces white or yellow, some milky, some incrustated and containing dirt; must be well washed. Province of Andévorante (east side): uneven, some fine pieces and others incrustated, needs washing and sorting. Province of Maroantsetra (east side): fine yellow and reddish pieces, some slightly milky, all with a slight incrustation; needs a little cleaning. Province of Maintirano (west side): some white pieces, mostly reddish-yellow; most is in fine pieces, some large, all in good condition, needing very little cleaning. In the following table they are arranged in the order of apparent value, based on the appearance of the varnishes made from them, which have not been tested for durability:

Madagascar Copals.	Acid Number.	Koettstorfer Number.
Maintirano	80.9	81.4
Tarafanga, first quality	93.8	98.2
Mananyary	80.9	87.0
Andévorante	79.0	74.0
Maroantsetra	76.4	64.5
Tarafanga, second quality	89.7	81.4

Resin Color reactions with Halphen's Reagent.—E. F. Hicks, *Jour. Ind. Eng. Chem.*, iii. 86. Reagent consists of (A) 1 volume phenol in 2 volumes CCl_4 and (B) 1 volume Br in 4 volumes CCl_4 . Powder a small portion of the resin (or of residue from Et_2O extraction), dissolve in 1–2 c.cm. solution A. With this fill a cavity in a porcelain color-reaction plate, so as to spread out around the margin of the cavity. Put 1 c.cm. solution B in an adjacent cavity, blow the vapor over A or cover with watch-glass. Colophony: green, then rapidly blue and violet, slowly to purple, finally indigo. Dammar: brown to lilac-brown, slowly; finally reddish-brown. Elemi: indigo blue,

IODINE AND BR. NUMBERS OF RESINS, COPALS, AND BALSAMS
(W. Vaubel, *Chem. Ztg.*, xxxiv. 978)

NAME.	VAUBEL.		LEWKOWITSCH.		RUDLING.
	I Br No.	II I No. Com- puted from Vaubel's Br No.	III I No. Computed from Br No.	IV I No. by Wids Sol.	V I No.
Colophony.....	120-130	190-206	302.6	133.7
Colophony.....	118	187
Burgundy pitch.....	79.8-88	126.5-139.5
White French resin.....	137.1-138.3
American resin.....	122.0-123.2
Dammar.....	174	275.8	169.4	127.5
Zanzibar copal.....	77	122
Manila copal.....	71.4	113	188.2	137.9	106.0-110.8 (a) 86.0- 90.6 (b)
Kauri copal.....	77.6	123	90.99
Copal-oil.....	72.2	114.4
Sandarac.....	91.8- 98.7
Yellow accaroid resin.....	160.0-191.5
Red accaroid resin.....	156.7-183.3
Elemi.....	83.6- 83.8
Dark shellac.....
Stick-lac.....	5-8	8-12.7	13.25	35.57	8.0- 19.5
Seed-lac.....	3.6- 8.6
Button-lac.....	19.0- 23.3
Turpentine I transparent	50.6	80.2
Turpentine II mercantile.	39.1	62.1
Turpentine, common....	49.6	78.7
Turpentine, Venetian....	49.1	77.9	148.5 (c)
Canada balsam.....	65.9	104.5	109.6 (d)

(a) Recovered from a solution. (b) Solid gum is used. (c) Refined. (d) Crude.

rapidly, permanent. Kauri: azure-blue, rapidly to purple, through violet; finally, remote from B, dark olive-green. Manila (spirit-soluble): faint brownish-green forms slowly; to violet, finally purple; remote from B, chocolate-brown. Mastic: reddish-brown, near carmine on side near B, coffee-brown remote from B. Sandarac: lilac, quickly, permanent, changes to violet, violet-brown remote from B. Shellac: no color. Zanzibar: slowly light-brown, later brownish-violet tending to chocolate. H₂O, EtO or EtOH interfere.

Tests for Turpentine, Wood-turpentine, and Rosin-spirit.
—C. Grimaldi, *Chem. Zt.*, xxxiv. 721; C. A., iv. 3013. Halphen's reagent gives satisfactory tests, if used with the following precautions. If petroleum or coal-tar distillates

are also present, the substance must be distilled and only the portion boiling below 170° may be used. Varnishes are distilled as by McIlhiney's method, 25-30 c.cm. with 50 c.cm. H_2O ; the volatile portion is separated from H_2O by standing, then dried with $CaCl_2$, redistilled in a flask with a side-tube and the first 2-3 c.cm. (boiled below 170°) saved for the test. One drop is put in a porcelain dish 4 cm. diameter, and 2 c.cm. of reagent is added; this is made of 1 volume crystallized carbolic acid and 2 volumes CCl_4 ; stir with a glass rod until completely dissolved, cover with a glass plate, introduce under the plate vapor of solution 1 pint Br to 4 pints CCl_4 . Rosin-spirit shows yellow, becoming green on shaking the dish, malachite-green on standing; wood-turpentine, in 15-60 seconds, shows carmine changing to violet; turpentine remains colorless, or at most shows a weak and pale yellowish-red.

A Use for the Gooch Filter in Paint Analysis.—W. I. Keeler, *Jour. Ind. Eng. Chem.*, ii. 388. With very fine pigments difficulty was found in separating the vehicle by the use of solvents or otherwise. Packing a Gooch filter with very fine asbestos through which the successive extractions were decanted, with suction, was successful. *C. A.*, iv. 3305.

Valuation of Turpentine as Siccative.—P. Klason, *Chem. Trade Jour.*, xlviii. 588, from *Chem. Ztg.* Distil in CO_2 , expose 10 c.cm. to air and diffused light twenty-four hours; to 5 c.cm. add 5 c.cm. of 5-per-cent solution of cymolsulphhydrate in EtOH in 30-c.cm. stoppered flask, shake well, stand in dark twenty-four hours, put in large flask with 100 c.cm. EtOH, titrate excess of cymolsulphhydrate with $\frac{N}{10}$ I. Test cymolsulphhydrate daily with I. No details are given as to surface exposed, temperature, humidity, etc.

Analysis of Turpentine-oils.—N. Chercheffsky, "Les Matieres Grasses" (1910), 3. The following constants are used to determine the origin and purity of turpentine: boiling-point; specific gravity at 15° ; index of refraction; critical temperature of solution (appearance of turbidity in a mixture of oil and 90-per-cent ethyl ether, warmed in a closed tube, then cooled); turbidity-point in solution of oil and acetic ether in open tube; Riche-Halphen number,

I number, acid number, flash-point; and residue on evaporation at 100° C.

Detection of Petroleum Derivatives in Oil of Turpentine.—Mennechet, *Bull. federation des pharmaciens Sud Ouest et Centre*, January, 1911. A pinch of powdered fuchsine and two drops of strong ammonia added to 4–5 c.cm. of the sample yield a bright red color in absence of petroleum and a brown-red color with as little as 5 per cent petroleum.

New Methods in the Varnish Industry.—L. E. Andès, *Chem. Rev. Fett-Harz-Ind.*, xvii. 294–96. For many years England has furnished the best varnishes for carriages, and while there the greatest care is observed to secure good raw materials, the continental manufacturers have obtained equally good results by substituting cheaper raw materials, such as rosin in the form of metallic resinates, and developing the processes of manufacture. The tendency is to produce by one single boil of all the ingredients a finished varnish. This has been accomplished and the product serves its purpose for many industries, but it pushes the more expensive and better copal-varnishes into the background. Two of the more recent patents are mentioned: terpineol is used as a solvent in combination with alcohol, oil of turpentine, benzine, etc., under pressure to dissolve the copal directly. From 20 to 200 per cent of terpineol is used on the basis of the resin, according to the nature of the resin, the fatty oil, and the kind of varnish desired. But the author believes that the high price of the terpineol will prevent a general use of this process. The other patent uses naphthalene as a solvent under pressure at a temperature of 220° – 290° , the fatty oil is then added, heated for one hour at the same temperature, and the naphthalene then distilled under vacuum. While this process offers many advantages, the author questions the possibility of obtaining a varnish of the fatty oil when the necessary oil of turpentine is added, and he deplors the tendency of the inventor to increase the complexity of apparatus and machinery where the manufacturer desires simplicity instead.

Hardened Resins.—Max. Bottler, *Chem. Rev. Fett-Harz-Ind.*, xvii. 292–94. Hardened resins are molten resinates

prepared from metallic oxides. They are manufactured primarily to raise the melting-point of the resins, especially such resins as remain sticky when mixed with drying-oils. The melting-point of resins may be increased by melting them with ZnO, CaO, etc., or treating at elevated temperature with air or O, or by converting them into ester compounds. In the case of copals the hardening is resorted to mainly to neutralize their free acids. Burnt marble is used mostly, but slaked lime has been shown to work best. These powders must be entirely soluble in resin, must be free from Fe, CO₂, and silicate, and must not form lumps in the varnish. The usual amount of the powder taken is 5 per cent and this will raise the melting-point of the resin by 50°-60°. With 10 per cent a lime resinat is obtained which no longer thickens with Pb and Zn colors. A still higher per cent of lime produces a dough-like mass, which at room temperature becomes brittle and cannot be remelted, but is still soluble in drying-oils. A complete neutralization of the resin is not easily accomplished and free lime is often found. The resinates are prepared by melting the resin at 180°, the slaked lime is added gradually, trials on glass plates showing when complete clarification has taken place; the temperature is then slowly raised to 270°, a higher temperature darkening the products. Dammar resins, viscous at 75° and a thin liquid at 150° (a few melt at 180°-200°) contain about 23 per cent free acid, and from 2-5 per cent of hardening powder. The same amount is employed for Manila copal (80 per cent free acids) kauri, hymenæa (South American copal), and East African copal. Such treated copals are not always completely soluble in turpentine or linseed-oil, nor are the lime resinates entirely resistant against water. When precipitated Al₂O₃ is used in place of Ca(OH)₂ the varnish becomes very hard and shows a dull lustre and is known as "hard-matt" varnish. ZnO and MgO are also employed, but their preparation is more difficult.

*Method of Calculating the Cost of Paint, from Analysis
(National Lead Co.)*

Volatile thinner, determined by analysis, in pounds, ÷ its specific gravity = equivalent pounds of water.

Non-volatile thinner, determined by analysis, in pounds, ÷ its specific gravity = equivalent pounds of water.

Each separate pigment, determined by analysis, in pounds, ÷ its specific gravity = equivalent pounds of water.

The sum (100 per cent) of these, in pounds = B.

Total equivalent pounds water = A.

$B \div A =$ specific gravity of paint = C.

$C \times 8.33$ (weight of 1 gallon water) = weight of 1 gallon paint = D.

Multiplying the per cent by weight of each separate ingredient, as found by analysis, by D, gives the fraction of a gallon of each ingredient. Multiplying each of these fractions by the cost per gallon of the ingredient, gives the cost of each ingredient. These added make the cost of 1 gallon paint, for materials.

The following is the laboratory blank for reporting paint analyses:

No..... Date.....

Paint or Vehicle (Brand or Description).....

.....

From.....

Weight of Can or Container.....

Specific Gravity..... Lbs. per Gal.....

Vehicle %..... Sp. Gr. $\frac{15.5^{\circ} \text{C.}}$

Pigment %..... " " $\frac{15.5^{\circ} \text{C.}}$ Calc.....

VEHICLE:

Volatile in steam.....% Sp. Gr. $\frac{15.5^{\circ} \text{C.}}$

Non-volatile in steam.....% " " $\frac{15.5^{\circ} \text{C.}}$ Calc.....

VOLATILE THINNER:

Refractive Index after Polymerization
 Polymerization Residue %

PROBABLE COMPOSITION:

.

VEHICLE:

Acid No. Unsaponifiable m. %
 Sap. No. Liebermann-S. Test
 Hanus I No. Resin Acids (Twitchell)
 Refractive Index Ash %
 Liebermann-S. Test

PROBABLE COMPOSITION:

. %
 %

PIGMENT DETERMINATIONS:

. %
 %
 %

PROBABLE COMPOSITION:

. %
 %
 %

CALCULATION ON COST, ETC., OF 100 LBS. OF SAMPLE

CONSTITUENT.	Lbs.	Sp. Gr. of.	Volume in Gallons.	Price.	Cost.
.....					
.....					
.....					
.....					
.....					
.....					
.....					
.....					
.....					
.....					

Cost per gallon.

REMARKS:

.....

Method for the Determination of "True Red Lead" (Used in the laboratory of the National Lead Company).—Solutions required:

1. "Red-lead Solution."—Weigh out into a 1,300-c.cm. beaker, preferably of Jena glass, 600 grammes C. P. crystalline sodium acetate and 48 grammes C. P. potassium iodide. Make up a solution of 25 per cent acetic acid, by mixing 150 c.cm. C. P. glacial acetic acid with 450 c.cm. distilled water. Now pour about 500 c.cm. of this 25-per-cent acid into the 1,300-c.cm. beaker, above mentioned, reserving the remainder. Warm the beaker on the steam-bath, stirring occasionally, until a clear solution is obtained. Cool this solution to room temperature, and pour it into a 1-litre graduated flask. Then add enough of the reserved 25-per-cent acetic acid to make exactly 1,000 c.cm. and mix thoroughly.

2. One-tenth N Sodium Thiosulphate Solution.—Weigh out into a large beaker 25 grammes C. P. crystalline sodium thiosulphate, add 400–500 c.cm. distilled water, and

stir until dissolved. Wash this solution into a 1-litre graduated flask, make up to the mark with distilled water, and mix thoroughly.

Each c.cm. of this solution is equivalent to about 3.48 per cent true red lead (using 1-gramme charge), but its exact value should be determined by standardizing against pure iodine or, better, against a standard sample of red lead, the "true red-lead" content of which is accurately known. The strength of this solution gradually decreases upon standing. It is a good plan, therefore, when analyzing a sample of red lead, to run a parallel determination with the standard red lead, thus ascertaining the exact strength of the thiosulphate solution. This procedure consumes but little extra time and will often prevent error.

3. Starch-indicator Solution.—Weigh out $\frac{1}{2}$ gramme of ordinary starch into a small beaker, add 10 c.cm. cold distilled water, and mix to a thin paste. Measure into another beaker 100 c.cm. distilled water, heat to boiling, and pour into it slowly, with constant stirring, the previously prepared starch paste. Then boil for two minutes, with constant stirring. This solution does not keep well and should be prepared fresh for each day's work.

Method.—Weigh 1 gramme of sample into a 300-c.cm. Erlenmeyer flask. Add a few drops of distilled water and rub the mixture to a smooth paste with a glass rod. Then add 50 c.cm. of the "red-lead solution" and continue rubbing with the glass rod until nearly all the red lead has been dissolved. Remove the rod from the solution and wash it off with 25 c.cm. of distilled water, making sure that all washings run into the flask. Titrate at once with the one-tenth N thiosulphate, adding the latter rather slowly and keeping the liquid constantly in motion by whirling the flask. When the color of the assay has been reduced to a light-yellow, examine it carefully for undissolved particles of red lead. If present, they can often be dissolved by shaking the flask for a short time, but if they dissolve too slowly, they should be crushed by rubbing again with the glass rod, until completely dissolved. The rod should then be removed and washed with a few cubic centimetres of water. After the addition of thiosulphate has reduced

the color of the assay to a very pale lemon tint and care has been taken to see that solution of the red lead is complete, add 2 c.cm. of the starch-indicator solution. The assay should then turn blue. Now finish the titrating by adding the thiosulphate solution, drop by drop, shaking the flask very thoroughly after each addition, until the blue color disappears.

Calculation.—Suppose, for instance, that a red-lead sample, by this method, requires 24.8 c.cm. of thiosulphate solution, and that the laboratory standard red lead requires 26.5 c.cm. of thiosulphate.

Then the per cent "true red lead" in the sample is:

$$\frac{92.00}{26.5} \times 24.8 = 86.1 \text{ per cent "true red lead."}$$

Notes.—Before analyzing a coarse sample, "glassmakers' red lead," for instance, it is necessary to grind the sample, thus rendering it more readily soluble.

Never attempt to hasten solution of the sample by warming, as this will cause loss of iodine, and, consequently, too low a result.

The "red-lead solution" should be kept in a cool, dark place, but even then, however, it may gradually decompose, with liberation of iodine. The error thereby introduced, in a determination, is not appreciable if the thiosulphate is freshly standardized, before use, against a standard sample of red lead, as recommended.

The main consideration, in this method, is to see that the determination is run in exactly the same way, and under exactly the same conditions, as the standardization of the thiosulphate, by means of the standard sample of red lead. Then any small errors in the determination will be offset by similar errors in the standardization.

The "acetate" method was tested out, in comparison with the distillation method, by analyzing the red-lead samples for the period ending June 30, 1911. The results are given below:

Red Lead Samples.	NO. OF C.CM. OF 0.1 N. THIO. USED.	
	Distillation.	Acetate.
Standard 92-per-cent red lead	26.35	26.48
“ “ “	26.43	26.50
“ “ “	26.30
“ “ “	26.40
Average	26.37	26.49
3 Coarse	22.77	22.82
3 Ordinary	25.22	25.28
3 C. M.	28.55	28.63
21	23.67	23.70
26	26.78	26.93
3 G. M.	15.10	15.10
31 G. M.	23.90	24.02
3 O. M.	27.15	27.28

(The same batch of thiosulphate was used for both methods, but the determinations by distillation were run 24 hours after the others.)

The results calculated to “true red lead” are as follows, the results obtained by the SnCl_2 method for the same period being also given:

SAMPLE.	SnCl_2 .	Distillation.	Acetate.
	Per Cent	Per Cent	Per Cent
3 Coarse	80.15	79.44	79.25
3 Ordinary	88.71	88.00	87.80
3 C. M.	97.08	99.61	99.43
21	81.36	82.58	82.31
26	93.49	93.42	93.53
3 G. M.	55.89	52.68	52.44
31 G. M.	84.43	83.39	83.42
3 O. M.	92.98	94.73	94.74

¹ *Testing Linseed-oil.*—Linseed-oil has recently become less abundant and of a higher price than formerly, owing to shortage caused by disease of the flax-plant, in the United States particularly; and this has stimulated the importation of foreign seed. In addition to this, the American Society for Testing Materials has carried on tests for

determining oil constants; these entirely differing causes have occasioned increased interest in linseed-oil tests.

The most important are the gravity and the iodine number; the latter is usually by the Hanus method, which is several units—perhaps five—higher than by the Hübl method. The committee of the American Society for Testing Materials recommended for North American oil, in 1909, that it should be considered pure raw oil when it tests between the following numbers:

Test.	Maximum.	Minimum.
Specific gravity at 15.5° C.	0.936	0.932
“ “ “ 25° C.	0.931	0.9270
Acid number	6.00
Saponification number	192	189
Unsaponifiable matter, per cent	1.50
Refractive index at 25° C.	1.4805	1.4790
Hanus iodine number	190	178

It has since been observed that oil made from imported seed has a lower iodine number than North American oil. Our laboratory has found Argentine seed-oil with an iodine number about 171; Gill reports 160 on pure raw oil, and Meister (*Farben-Zeitung*, vol. xvi. No. 1) says the lower limit of the iodine number for pure oil is 170, but recently oils of undoubted purity were found with the iodine numbers 164.5, 161.1, and 160.2. Making allowance for these being Hübl numbers, which was certainly the case with Dr. Gill's experiments, these numbers are too low; at least, such oil would not be considered of "undoubted" purity in our laboratory. Even if we made it from the seed in the laboratory, we would wish to know the history of the seed. It is not impossible that long keeping, especially if in a very warm place, might lower the iodine number in the seed itself. It may be that this is why seed which has a long shipment across the tropics always has a low iodine number as compared with our local product.

Not feeling very confident about the constants of ether-extracted oil, we recently constructed a laboratory press for pressing oil from seeds; we find the oil to be practically

the same as that from the same seed made in the factory. Although there may be from 2 to 6 per cent of impurities, this consists mainly of chaff and absorbs oil rather than gives it out. Moreover, oil ether-extracted from some of these impurities recently, gave the iodine number 160. With this press we have made numerous samples of oil from pure clean hand-picked seed. In the following table the seed was pure unbroken seed, impurities removed by picking out the clean seed by hand. The oil is total oil present, extracted by ether.

Flax-seed.	Per Cent Oil.	Per Cent Impurities.	Weight per Seed in Milligrammes.	Specific Gravity of Seed.	Number of Seeds in the Test.
North American		2.19	4.54		4,000
La Plata	37.25	4.15			600
La Plata	37.18		5.55		1,800
La Plata			5.58	1.1415	4,200
Calcutta			5.33	1.1378	700
"	41.35	6.5	5.10	1.1290	1,500
"	40.41		5.18		200
"	36.75	6.69	5.24		200
Bombay	41.23		7.92		500
Kertch, S. Russia . .	39.11		5.74		1,500
Riga, Russia	36.95		4.17		200
Novotonsk, Russia . .			4.99		200
Turkish	43.01	5.15	7.45	1.1327	1,000

During the oxidation of linseed-oil the iodine number rapidly lowers, and the specific gravity very slowly rises. Oil having specific gravity 0.9352 oxidized into a film having specific gravity 1.100, it increased in specific gravity 18 per cent. Almost anything that is done to linseed-oil lowers its iodine number.

No constants for boiled oil have as yet been adopted, even provisionally. The American Society for Testing Materials now has the matter under consideration.

TESTS FOR THE LINSEED-OIL, AS USED BY COMMITTEE D1,
AMERICAN SOCIETY FOR TESTING MATERIALS

General.—All tests are to be made on oil which has been filtered at a temperature of between 60° and 80° F. through paper in the laboratory immediately before weighing out, except tests No. 2—Turbidity and Fouts; No. 4—Moisture and Volatile Matter; and No. 5—Ash. The sample should be thoroughly agitated before the removal of a portion for filtration or analysis.

1. *Specific Gravity.*—Use a pyknometer, accurately standardized and having a capacity of at least 25 c.cm., making a test at 25° C., water being 1 at 25° C.; and another test at 15.5° C., water being 1 at 15.5° C.

2. *Turbidity and Fouts.*—By allowing 25 c.cm. of the oil to stand between 60° and 80° F. for two weeks in a graduated glass tube, 1 cm. in diameter, reporting amount of sediment found in cubic centimeters or in fractions thereof.

3. *Breaking Test.*—By heating a portion of the oil, say 15 c.cm., in a 5/8 x 6-in. test-tube over an open flame to 300° C., the temperature to be determined by a thermometer suspended in the oil. The rise in temperature should not exceed 50° per minute. Report whether oil breaks or not.

4. *Moisture and Volatile Matter.*—(a) Loss sustained by 2 grammes of the oil in a 4-oz. Erlenmeyer flask at 105° C. in a current of dry hydrogen or pure carbonic-acid gas (free from sulphur) to constant weight. (b) Loss sustained by 5 grammes of oil in a 2½-in. uncovered Petri dish at 100° C. in an ordinary steam-jacketed oven for two hours.

5. *Ash.*—By burning 10 grammes to complete combustion and to a light-gray residue in a porcelain crucible or dish at a dull red heat.

6. *Drying Test on Glass.*—Follow Archbutt's method ("A piece of polished plate-glass 7 cm. square by 4 mm. thick is cleaned and counterpoised on the balance; it is then heated for an hour at 200° C. in an air-bath to dry thoroughly. It is taken out and laid on a non-conductor, allowed to cool for three or four minutes, and the hot glass thinly painted with the oil to be tested, using a camel-hair brush. When the glass is cold it is weighed and sufficient

oil added to make it up to 0.1 gramme."—Gill's description) in the preparation of the glass slips and their coating with oil, placing in an atmosphere moderately dry, say a closet desiccator dried with sulphuric acid in which the moisture is not more than 25-per-cent saturation (temperature 60° to 80° F.). Report time required for the oil to become dry to the touch—*i.e.*, no oil sticks to or is removed by the finger when touched lightly.

7. *Acid Number*.—Expressed in milligrammes of KOH per gramme of oil. Follow the method described in Department of Agriculture, Bureau of Chemistry, *Bulletin* 107, revised page 142.

8. *Saponification Number*.—Expressed as with acid number and stating length of time test is run. Blanks should also be run to cover effect of alkali in glass. Follow the method given in the above-referred-to *Bulletin* 107, pp. 137-138.

9. *Unsaponifiable Matter*.—Follow Boemer's method taken from Ubbelohde's "Handbuch der Oele und Fette," pp. 261-62. "To 100 grammes of oil in a 1,000- to 1,500-c.cm. Erlenmeyer flask add 60 c.cm. of an aqueous solution of potassium hydroxide (200 grammes KOH dissolved in water and made up to 300 c.cm.) and 140 c.cm. of 95-per-cent alcohol. Connect with a reflux condenser and heat on the water-bath, shaking at first until the liquid becomes clear. Then heat for one hour with occasional shaking. Transfer while yet warm to a 2,000-c.cm. separatory funnel to which some water has been added, wash out the Erlenmeyer with water, using in all 600 c.cm. Cool, add 800 c.cm. of ether, and shake vigorously one minute. In a few minutes the ether solution separates perfectly clear. Draw off the soap and filter the ether (to remove last traces of soap) into a large Erlenmeyer, and distil off the ether, adding if necessary one or two pieces of pumice-stone. Shake the soap solution three times with 400 c.cm. of ether, which add to the first ether extract. To the residue left after distilling the ether add 3 c.cm. of the above KOH solution, and 7 c.cm. of the 95-per-cent alcohol, and heat under reflux condenser for ten minutes on the water-bath. Transfer to a small separatory

funnel, using 20 to 30 c.cm. of water, and after cooling shake out with two portions of 100 c.cm. of ether; wash the ether three times with 10 c.cm. of water. After drawing off the last of the water, filter the ethereal solution so as to remove the last drops of water, distil off the ether, dry residue in water oven, and weigh."

After determination of unsaponifiable matter, convert it to acetate and determine the melting-point of the acetate as directed by Lewkowitsch, p. 372, third edition.

10. *Liebermann-Storch Test*.—Qualitative. Follow the method described in *Bulletin* 107 of Department of Agriculture, Bureau of Chemistry, referred to above.

11. *Refractive Index*.—Using Abbê Refractometer at 25° C.

12. *Acetyl Value*.—Follow Benedikt-Lewkowitsch method. See Department of Agriculture, Bureau of Chemistry, *Bulletin* 107, revised p. 142.

13. *Iodine Number*.—Follow the Hanus method as described in Department of Agriculture, Bureau of Chemistry, *Bulletin* 107, revised p. 136.*

Formation of Flocks in Linseed-oil and Varnish-oil.—J. Hertkorn, *Chem. Zgt.*, lii. 462. The formation of flocks in linseed-oils during the boiling process is often due to the presence of fatty acid glycerides and not to the presence of carbohydrates or fatty matter from the seed. These glycerides polymerize and in so doing enclose linseed-oil in the solidifying jelly. Upon heating and stirring the jelly breaks, liberating spongy flakes. These flakes harden in the presence of the air and sometimes ignite spontaneously causing fires in the boiler. Chinese wood-oil and candle-nut-oil are the chief adulterants. Thin linseed-oil may be pure, showing no gelatinization, but skins and flakes may be formed. If even a few tenths of a per cent of wood-oil is present, gelatinization will take place when heated to 240° C. The thin oils are more liable to adulteration since the adulterants are more viscous than normal linseed-oil. Gelatinization will be produced if a barrel which contained

* Note:—These references to *Bull.* 107 are to be found on pp. 235-283 of this book.

wood-oil is used for linseed-oil. The danger of fires in the blowing process can be eliminated by heating the oil for a long time at 150° – 260° C., allowing the flakes to settle and pouring off the oil. The flaky residue is very useful for making varnish-oil. *Chemical Abstracts*, iv. 2743.

Iodine Number of Linoxyn.—Meister, *Rev. chim. ind.*, xxi. 368. The oil films weighed 0.005–0.007 gm. per square centimetre. When exposed not more than 2 hours dissolve in CHCl_3 ; not over 6 hours, in cold $\text{HC}_2\text{H}_3\text{O}_2$; not over 10 hours, in hot $\text{HC}_2\text{H}_3\text{O}_2$. Some insoluble particles after 10 hours' exposure; after 48 hours only 50-per-cent solution in hot $\text{HC}_2\text{H}_3\text{O}_2$. Tung-oil becomes rapidly insoluble.

Raw Linseed-oil with 3 per cent resinate Pb and Mn.

Dry

		Two Hours.	Four Hours.	Six Hours.	Eight Hours.	Ten Hours.	Twelve Hours.
Iodine No. (Hübl) ..	153.8	131.6	105.0	73.9	47.3	26.9(?)
Increase in weight	5.4	10.2	16.8	17.9	18.0

Raw Linseed-oil with 3 per cent resinate Pb and Mn.

Tacky

		Two Hours.	Four Hours.	Six Hours.	Eight Hours.	Ten Hours.	Twelve Hours.
Iodine No. (Hübl) ..	156.8	136.1	104.0	74.8	48.8	29.1(?)
Increase in weight	5.1	10.0	16.2	17.4	18.0

Tung-oil with 3 per cent resinate Pb and Mn.

Dry

		Two Hours.	Four Hours.	Six Hours.	Eight Hours.	Ten Hours.	Twelve Hours.
Iodine No. (Hübl) ..	148.8	143.1
Increase in weight	0.9	4.2

Tung Oil with 3 per cent resinatc Pb and Mn.

Tacky

		Two Hours.	Four Hours.	Six Hours.	Eight Hours.	Ten Hours.	Twelve Hours.
Iodine No. (Hübl)...	144.9	138.9
Increase in weight...	0.6	5.0

Perilla-oil.—Meister, *Farben-Ztg.*, xvi. No. 6; through *Chem. Rev. Fett-Harz-Ind.*, xvii. 296-97. The oil is obtained from the seeds of *Perilla ocymoides*, cultivated in Japan, Manchuria, and the Himalayas. The seeds contain 38 per cent oil; seeds and oil are edible. The oil is used for varnishes, printing-ink, waterproofing of fabrics and paper, also for drying. Analysis gave the following results: specific gravity 0.9310, free acids 5.5 per cent, saponification number 192.1, I number 194.7, hexabromide yielded 53.3 per cent; elaidine test gives liquid product; Halphen and Bandouin tests are negative. Fatty acids: melting-point -4° , saponification number 197.1, I number 198.2. The unpurified Br product has a melting-point of 160° - 170° , indicating linoleic acid. The oil on drying crawls together like drops of Hg, but this can be avoided by rapidly heating the oil to 250° , when a firm, glossy, uniform coating is obtained after 5 hours if a drier is added; its color is lighter than that of the linseed-oil pellicle. Florida earth bleaches the oil almost water-white and it does not darken afterward. Because the oil can be boiled without becoming viscous, it is suitable for printers' ink and for lithographic purposes. If the price of this oil could be properly regulated, it would make an excellent substitute for linseed-oil.

Chinese Wood-oil.—A. Guiselin, "Matières Grasses," iii. 1689, 1729, and 1762. Oil imported into France under the name of Chinese wood-oil is of two distinct kinds: one the product of *Elæococca vernicifera* or abrasin, the other of *Aleurites cordata* or camiri or bancoulier. The constants given by various authorities for wood-oil apply sometimes to one, sometimes to the other, and sometimes partly to each. The oil of *Aleurites* appears to have the higher iodine

value (and corresponds more closely to the commercial oil used in the United States). The author obtained some seeds of *Elæococca*, and found four different samples of the oil pressed or extracted from these, $d_4^{20} = 0.9340$ to 0.9461 ; iodine number of fatty acids, 123-157. He recommends that authentic samples of both varieties of seeds be obtained and new determinations of the constants made.

Preparation of Oils for the Painter.—W. N. Blakeman, "Les corps gras industriels," xxxv. 370. The author recommends that tung- or China wood-oil be made rancid in order to be better fitted for the painter's art. This is done by adding 2 per cent water to the oil in a suitable vessel, heating to 65° C. and shaking, and then allowing to stand 10 to 15 hours, or the oil may be exposed over a large surface to light and air for 8 to 10 days until a proper degree of rancidity has been secured. An oil treated in this manner, it is claimed, allows the incorporation, with ease, of all colors which cause difficulty with linseed-oil.

METHOD OF ANALYSIS OF CELLULOID

(Privately communicated)

After finely shredding the sample, dissolve a portion in acetone, or other volatile solvent, which is miscible with water, to a comparatively thin solution and allow to stand for some time to allow pigments and insoluble salts to settle out or be filtered out for examination.

The solution or filtrate will contain the pyroxyline, gums, resins, camphor, etc., which may be precipitated by pouring the solution slowly into water, stirring constantly, thus obtaining a finely divided precipitate and also making it possible for any oils which may be present to separate and rise to the surface, thus permitting separation. The water will hold in solution most, if not all, dyes present and the soluble salts, such as urea, which are largely used to prevent decomposition of the nitrocellulose. These dyes and salts may be tested and determined in the water solution by filtering and thoroughly washing the precipitate. The precipitate may next be placed in a suitable vessel with fresh

water and boiled, when the camphor will be carried off with the steam and sublimed for weighing.

From the residue the gums and resins may be extracted with alcohol and determined by prescribed methods.

Having thoroughly washed the precipitate with alcohol, it should be dried at a moderate temperature, being careful not to cause decomposition by prolonged or overheating. When dry weigh for determination of pyroxyline. If it is desired to examine this further in order to ascertain the degree of nitration of the pyroxyline, a portion of this residue (0.15 to 0.20 grammes) may be weighed and placed in the funnel to a Lunge nitrometer into which has been previously placed a small quantity of concentrated H_2SO_4 . With a little stirring with a glass rod the nitrocellulose should dissolve and is then run into the nitrometer and the funnel and rod washed several times with H_2SO_4 until no trace is left in funnel. The determination is then carried out according to the method of Walter Crum (Winkler and Lunge, "Gas Anal." or Sutton, "Vol. Anal."). A check on the camphor may be made by boiling some of the original sample and collecting what sublimes. By dissolving another portion of the celluloid in boiling KOH the fatty oils will be converted into soluble soaps which can be determined in the usual way, and should camphor substitutes, such as phenols, be present they would be detected by their distinct odor.

DETERMINATION OF NITRIC ACID

By Crum's Method and Lunge's Nitrometer

Turn the three-way stopcock of the nitrometer so that the graduated portion of the tube is in connection with the funnel above; raise the reservoir-tube until the mercury flows into the funnel; turn the stopcock so as to allow the Hg in the funnel to flow out at the side, then turn again so as to close the funnel. Place in the funnel about 2 to 3 c.cm. concentrated H_2SO_4 C. P. free from oxides of nitrogen. Run into the above H_2SO_4 the measured quantity (0.80 c.cm.) of HNO_3 mixture to be tested; lower reservoir tube and turn stopcock, allowing nearly all of liquid in the funnel to be

drawn down into the nitrometer; then wash funnel with H_2SO_4 (about 2 c.cm.) by shaking the standard to which nitrometer is clamped, then allow this to run into nitrometer and continue to wash and draw in until top of Hg registers 8 c.cm., keeping this amount uniform to facilitate adjustment at end of reaction. Now wash out funnel with water to prevent acid being thrown around while shaking. Remove nitrometer from standard and shake vigorously until gas ceases to be given off (about 2 minutes), then put nitrometer back into standard, about equalizing levels of Hg, and allow to stand until it cools to temperature of room. Having previously found how much Hg is needed in reservoir tube to equalize 8 c.cm. liquid in nitrometer and marked it on card, now bring Hg in nitrometer to top of clamp and then raise Hg in reservoir to mark on card which will balance liquid above Hg in nitrometer; now take reading of volume gas NO and temperature and barometer; then open stopcock, and if reading increases, deduct the increase from original reading, or if it decreases, add it to original reading because Hg pressure has been too little or too great.

Reaction: $2\text{HNO}_3 + 6\text{Hg} + 3\text{H}_2\text{SO}_4 = 2\text{NO} + 3\text{Hg}_2\text{SO}_4 + 4\text{H}_2\text{O}$. Nitrous acid and nitrogen dioxide are reduced in the same way. The reaction is not affected by organic matter. In the measurement and correction of gas volume no allowance is made for aqueous vapor tension as the gas being measured over H_2SO_4 is dry.

The correction of levels in the two tubes is scientifically made by multiplying the change in millimetres by 2 and adding or deducting from barometer pressure because the error is really a pressure of 1 millimetre of Hg and we multiply by 2 because whatever change takes place in one tube, an equal change takes place in other tube, so the original difference was double the measurement in one tube.

Calculation: Assume the mixed acids have a specific gravity 1.710 at about 20°C . We take our gravities at 20°C . as that is about the temperature at which they are found ordinarily.

For the determination of HNO_3 , 25 c.cm. mixed acid are

run into 100 c.cm. C. P. sulphuric and mixed. 0.80 c.cm. above mixture are run into nitrometer.

Specific gravity 1.710 \times 25 c.cm. = 42.75 gms. in 125 c.cm.

$$\frac{42.75}{125} = 0.342 \text{ gms. mixed acid in 1 c.cm.}$$

$$0.342 \text{ gms.} \times 0.8 = 0.2736 \text{ gms. used.}$$

1 CCNO weighs 0.00134172 gms. = 0.00281609 gms. HNO₃.

Then corrected

$$\text{CCNO} \times 0.00281609 = 0.2736 \times 100 \text{ per cent HNO}_3 \text{ found.}$$

(See tables for correction—

$$\text{volume gas to } \frac{0}{760} \text{ CCNO to per cent HNO}_3.$$

$$\text{Per cent HNO}_3, \text{ to CC } \frac{N}{\text{KOH}} \text{ CC } \frac{N}{I} \text{ KOH to per cent H}_2\text{SO}_4.$$

These tables we have worked out for reference to save figures.

Say results were 25 per cent HNO₃, 27 c.cm. KOH $\frac{N}{I}$.

$$25 \text{ per cent of } 1.71 \text{ gms. (weight of 1 c.cm.)} = \\ 0.4275 \text{ gms. HNO}_3.$$

A normal solution,

HNO₃ contains 0.06305 gms. HNO₃ per 1 c.cm.

$$\text{Then } \frac{42.75}{.06305} = 6.78 \text{ c.cm. } \frac{N}{I}$$

$$\text{deducting from } 27.00 \text{ c.cm. } \frac{N}{I} \text{ KOH}$$

$$6.78 \text{ c.cm. } \frac{N}{I} \text{ HNO}_3$$

$$\hline 20.22 \text{ c.cm. } \frac{N}{I} \text{ H}_2\text{SO}_4$$

1 c.cm. $\frac{N}{I}$ H₂SO₄ contains 0.049045 gms.

$$\text{Then } 0.049045 \times 20.22 = \text{gms. H}_2\text{SO}_4 \frac{0}{1.710} = \text{per cent H}_2\text{SO}_4.$$

ANALYSIS OF MIXED ACIDS

(Nitric Off Method)

Thoroughly cleanse the weighing tube (Lunge's pipette is a desirable form) with water, followed by wood alcohol to expedite drying. Then weigh the empty tube by suspending with a platinum wire from the hook on the balance beam, next fill the tube with the acid to be analyzed by sucking out the air through a piece of rubber tubing, taking care not to let the acid get above the upper stopcock. Do not suck out the air by placing the end of the tube in the lips, because saliva will accumulate above the stopcock and falsify the weighing. Having filled the tube with acid, weigh it, and measure off, by weight, two portions of the acid into small porcelain dishes. From 1 to 2 grammes is the right amount. Any fumes that may escape make no difference, because only the nitric acid is volatile at room temperature, the sulphuric remaining behind.

A. (Acid in the porcelain dishes [duplicates].)—Place the porcelain dishes containing the weighed acid upon the steam-bath and turn on a gentle flow of steam. After 30 minutes add a few cubic centimetres of distilled water and evaporate again. One hour is amply sufficient to remove all traces of the nitric acid. Dilute the residue of sulphuric acid with about 50 c.cm. of distilled water and titrate with standard KOH solution and calculate the per cent of acid present.

B. (Acid left in weighing tube.)—Dilute the acid in 300-400 c.cm. of distilled water contained in a beaker, and be sure not to allow any of the acid fumes to escape. It is best to stir the diluted acid as the tube is emptying, thus preventing any loss of fumes. Thoroughly cleanse the two parts of the weighing tube and put the rinse water into the same beaker. It is found best to rinse the pipette and stopcock by downward displacement, *i.e.*, attach a small funnel and rubber tube, and run several small portions of distilled water through the whole length, shaking it in order to bring the water in contact with all parts of the tube.

Keep the end of the tube under water as it is shaken, else some fumes will be lost. Place contents of beaker in a 500-c.cm. measuring-flask and dilute to the mark. Determine total acid contents by titrating 50-c.cm portions. Duplicates should agree to one-hundredths of a cubic centimetre. Titrate total acid and calculate the per cent in terms of sulphuric acid.

An example will not be out of place:

A. 1—46.038 grammes

44.865

$$1.173 \text{ grammes} = 16.85 \text{ c.cm. } \frac{N}{I} \text{ KOH}$$

—44.865

43.556

$$1.309 \text{ grammes} = 18.75 \text{ c.cm. } \frac{N}{I} \text{ KOH}$$

B. $\frac{43.556}{32.258}$ (weight empty tube).

11.298 grammes

diluted to 500 cm., then 50 c.cm. of this

$$= 19.10 \text{ c.cm. } \frac{N}{I} \text{ KOH} =$$

$$19.10 \times 10 = 191 \text{ c.cm. } \frac{N}{I} \text{ KOH} = 11.298 \text{ grammes}$$

0.049045 = molec. equivalent H_2SO_4 .

$$\frac{49045 \times 16.85}{1.173} = 70.45 \text{ per cent } \text{H}_2\text{SO}_4$$

average = 70.35 per cent

$$\frac{49045 \times 18.75}{1.309} = 70.25 \text{ per cent } \text{H}_2\text{SO}_4.$$

$$\frac{49045 \times 191}{11.298} = 82.9 \text{ per cent total acid in terms of } \text{H}_2\text{SO}_4$$

$$82.9 - 70.35 = 12.55 \times \frac{9}{7} = 16.13 \text{ per cent } \text{HNO}_3$$

Hence $\begin{cases} \text{HNO}_3 = 16.1 \text{ per cent.} \\ \text{H}_2\text{SO}_4 = 70.4 \text{ per cent.} \end{cases}$

RECENT LITERATURE

- Acetone, A rapid method for the determination of. A. P. Sy, *J. Am. Chem. Soc.*, xxix. 786; *C. A.*, ii. 38. Determination in crude wood naphtha.
- Aluminium soaps for varnishes. *Chem. Ztg.*, xxxii. 102; *C. A.*, ii. 1191.
- Beeswax, Saponification of. G. Buchner, *Chem. Ztg.*, xxxi. 126, 1085; *C. A.*, i. 1065; ii. 471. R. Berg, *Chem. Ztg.*, xxxii. 777-780; *C. A.*, ii. 3005.
- Analysis of. K. D. Helfenberg, *Chem. Ztg.*, xxxi. 987; *C. A.*, ii. 192; K. Dieterich, *Pharm. Post.*, xl. 639; *C. A.*, 714.
- Conduct of, to ether. G. Buchner, *Chem. Ztg.*, xxxi. 570; *C. A.*, i. 2161.
- Benzine, Qualities of. W. Witt, *Farb. Ztg.*, xiv. 47; *C. A.*, iii. 3009. L. E. Andes, *Rev. Fett-Harz-Ind.*, xvi. 248; *C. A.*, iii. 3009.
- Determination of, in turpentine. J. Marcusson, *Rev. Fett-Harz-Ind.*, xvii. 610; *C. A.*, iv. 1541. A. Eibner and O. Hue, *Chem. Ztg.*, xxxiv. 643, 657; *C. A.*, iv. 3134.
- Bleaching-oil. A. Metz and P. L. Clarkson, *Les corps gras ind.*, xxxiv. No. 1; *C. A.*, ii. 194. Pen-Hoarn, *Matières grasses*, ii. 1443; *C. A.*, iv. 968.
- Camphor, The origin and production of. H. H. Rusby *et al.*, *J. Soc. Chem. Ind.*, xxvi. 380; *C. A.*, i. 1759.
- Determination of, in celluloid by the refractometer. Utz, *Gummi-Ztg.*, March 15, 1907; *C. A.*, i. 1467.
- In celluloid, A. Arnost, *Z. Nahr. Genussm.*, xii. 532; *C. A.*, i. 156.
- Determination from artificial. Utz, *Gummi-Ztg.*, xxii. 21; *C. A.*, ii. 887.
- Catalysis, Theory of. F. Raschig, G. Bredig, R. Luther, *Z. angew. Chem.*, xix. 1748, 1985, 2049, 2083; *C. A.*, i. 137, 522.
- Cellulose, Theory of nitration of. A. Saposhnikov, *J. Russ. Phys. Chem. Soc.*, xxxviii. 1192; *C. A.*, i. 1324.
- Acetate. W. H. Walker, *J. Frank. Inst.*, 164, 131; *C. A.*, ii. 318.

- Corn-oil, Determination of. W. McPherson and W. A. Ruth, *J. Am. Chem. Soc.*, xxxix. 921. *C. A.*, i. 2948; ii. 331.
- Corrosion of Iron. F. Bergius and P. Krassa, *Z. Electrochem.*, xv. 712; *C. A.*, iv. 418. F. Cheesman, *Eng. News*, lxi. 524; *C. A.*, iii. 2062. Coslett, *Engineering*, lxxxv. 870; *C. A.*, ii. 2540. A. S. Cushman, *Electrochem. Met. Ind.*, v. 256; *C. A.*, i. 2360; *U. S. Dept. Agr., Office Pub. Roads, Bul.* xxx. 35; *C. A.*, ii. 257, 1659, 1814; iii. 758; iv. 39; *Chem. Eng.*, vii. 63; *C. A.*, ii. 2540, 2923; *Proc. Am. Soc. Test. Mat.*, viii. 605; *C. A.*, iii. 1468; *Engineering*, lxxxvii. 710; *C. A.*, iv. 737. G. Despierres, *J. Roy. Soc. Arts*, lvii. 361; *C. A.*, iii. 1632. W. L. Dudley, *Progressive Age*, xxvi. 137; *C. A.*, ii. 1815. J. N. Friend, *Engineering*, lxxxviii. 526, 531; *C. A.*, iv. 1974, 2435. R. H. Gaines, *Eng. News*, lix. 578; *C. A.*, ii. 2775; *Engineering*, lxxxviii. 272, 304; *C. A.*, iii. 2673; *J. Ind. Eng. Chem.*, ii. 135; *C. A.*, iv. 1597. E. C. Heyn and O. Bauer, *Mitt. Kgl. Materialprüfungsamt*, xxvii. 57; xxviii. 62, 1564; *C. A.*, iii. 2551, 301; iv. 1863. H. M. Howe, *Pr. Am. Soc. Test. Mat.*, vi. 155; viii.; *C. A.*, i. 1383; ii. 2923. W. P. Jorissen, *Chem. Weekblad*, v. 364; *C. A.*, iii. 1632. R. T. Kanski, *Eng. News*, lx. 211; *C. A.*, ii. 2922. A. Knudson, *J. Frank. Inst.*, clxviii. 132; *C. A.*, iv. 1735. G. T. Moody, *Proc. Chem. Soc.*, xxiii. 84; xxv. 24; *C. A.*, i. 1365; iv. 2627. H. J. Morrison, *Eng. News*, lix. 681; *C. A.*, ii. 2540. M. T. Murray, *J. Chem. Met. S. Afr.*, x. 54; *C. A.*, iv. 165. W. Rosenhain, *Iron Age*, lxxxiv. 1556; *C. A.*, iii. 2923. A. H. Sabin, *Eng. News*, lix. 673; *C. A.*, ii. 2725. A. Sang, *Proc. Eng. Soc., W. Pa.*, xxiv. 493; *C. A.*, iii. 2673; *Electrochem. Met. Ind.*, vii. 351; *C. A.*, iii. 2796. A. Schleicher, *Metallurgie*, vi. 182; *C. A.*, iv. 1974; A. Schleicher and G. Schultz, *Stahl u. Eisen*, xxviii. 50; *C. A.*, ii. 985. E. C. Sherman, *Eng. News*, lxi. 292; *C. A.*, iv. 165; J. C. Smith, *Engineering*, lxxxvii. 660; *C. A.*, iii. 2062. T. N. Thompson, *Iron Age*, lxxxi. 434; *C. A.*, ii. 1118. W. A. Tilden, *Proc. Chem. Soc.*, xxiv. 169; *C. A.*, ii. 3050. M. Toch, *Pr. Am.*

- Soc. Test. Mat.*, vi. 150; *C. A.*, i. 1383; *Trans. Am. Electrochem. Soc.*, xiv. 207; xv. 391; *C. A.*, iii. 1496, 2538. W. H. Walker *et al.*, *Electrochem.-Met. Ind.*, v. 270; vi. 492; *C. A.*, i. 2360; iii. 2133; *J. Am. Chem. Soc.*, xxix. 1251; xxx. 473; *C. A.*, i. 2791; ii. 2068; *Engineering*, lxxxvii. 708 (*Electrician*, lxiii. 217); *C. A.*, iii. 2113; iv. 575; *J. Ind. Eng. Chem.*, i. 754; *C. A.*, iv. 254. A. R. Watrous and W. S. Davey, *J. Soc. Chem. Ind.*, xxix. 657; *C. A.*, iv. 2256. D. C. Webb, *Eng. News*, lxiv. 230; *C. A.*, iv. 2922. B. J. Wigersma, *Chem. Weekblad*, v. 390; *C. A.*, iii. 1632.
- Elemi. A. M. Clover, *Philipp. J. Sci.*, ii. 1-40; *C. A.*, i. 2158; *Am. Chem. J.*, xxxix. 613; *C. A.*, ii. 1971. P. Stoepel, *Apoth. Ztg.*, xxiii. 440; *C. A.*, iv. 79.
- Essential Oils, Variation of constants with temperature. A. Haller and H. Goult, *Bul. Soc. Encouragement*, cix. 699; *C. A.*, i. 2814.
- Graphite. F. Wüst, *Metallurgie*, iii. 757; *C. A.*, i. 710. H. L. Dejust, *Compt. rend.*, cxliv. 1294; *C. A.*, i. 2353. E. G. Acheson, *Eng. News*, liii. 127; *C. A.*, i. 2940; *J. Frank. Inst.*, clxiv. 375; *C. A.*, ii. 1389. H. Le Chatelier and S. Wologdine, *Rev. Métall.*, v. 140; *C. A.*, ii. 1818. F. D. Chester, *Eng. Min. J.*, lxxxviii. 824; *C. A.*, iv. 1595.
- Japanese lacquer. R. Majima and S. Chō, *Ber.*, xl. 4390; *C. A.*, i. 541. K. Miyama, *J. Coll. Eng. Imp. Univ. Tokio*, iv. 89, 201; *C. A.*, iii. 3012, 1218, 1596. R. Majima, *Ber.*, xlii. 1418, 3664; *C. A.*, iii. 2297; iv. 203.
- Juniper-oil. J. Rodie, *Rev. gén. chim.*, ix. 444; *C. A.*, i. 1042; *Bul. soc. chim.*, xxxv. 922; *C. A.*, i. 86.
- Kaya-oil. M. Tsujimoto, *J. Coll. Eng. Imp. Univ. Tokio*, iv. [3]; *C. A.*, ii. 2736.
- Lead, Red. A. Partheil, *Arch. Pharm.*, ccxlv. 519; *C. A.*, ii. 690. E. Pieszczyk, *Pharm. Ztg.*, liii. 87; *C. A.*, ii. 1493. E. E. Dunlap, *J. Am. Chem. Soc.*, xxx. 611; *C. A.*, ii. 1895; P. Beck, *Z. anal. Chem.*, xlvi. 465; *C. A.*, ii. 2767. R. Wahle, *Chem. Ztg.*, xxxiii. 998; *C. A.*, iv. 238. J. Milbauer, *Chem. Ztg.*, xxxiii. 522; xxxiv. 138; *C. A.*, iv. 28, 1434.

- Lead sulphate. L. S. Hughes, *Eng. Min. J.*, lxxxiv. 356; *C. A.*, ii. 593; *J. Soc. Chem. Ind.*, xxviii. 405; *C. A.*, 1817.
- Lead, White. W. A. Davis and C. A. Klein, *J. Soc. Chem. Ind.*, xxvi. 848; *C. A.*, i. 2749. G. W. Thompson, *J. Soc. Chem. Ind.*, xxviii. 406; *C. A.*, iii. 1817. C. D. Holley, *J. Soc. Chem. Ind.*, xxviii. 403; *C. A.*, iii. 1817. J. A. Yunck, *Chem. News*, c. 83; *C. A.*, iv. 121. J. S. Staudt, *J. Ind. Eng. Chem.*, i. 758; *C. A.*, iv. 253. Editorial, *Engineering*, lxxxix. 51; *C. A.*, iv. 833. Editorial, *Oil, Paint and Drug Rep.*, lxxvii. 3, 15; *C. A.*, iv. 833. H. Hof, *Chem. Ztg.*, xxxiii. 1077; xxxiv. 266, 784; *C. A.*, iv. 2210, 2812, 3013. L. Falk, *Chem. Ztg.*, xxxiv. 557, 567, 737, 833; *C. A.*, iv. 2580, 3012, 3013. J. F. Sacher, *Chem. Ztg.*, xxxiv. 647, 737, 832; *C. A.*, iv. 2383, 3012, 3013.
- Linolenic acid. E. Erdmann and F. Bedford, *Ber.*, xlii. 1324; *C. A.*, iii. 2165. A. Rollett, *Z. physiol. Chem.*, lxii. 422; *C. A.*, iv. 1295.
- Linseed-oil. A. Geuther, *Z. angew. Chem.*, xix. 2087; *C. A.*, i. 912. S. A. Fokin, *J. Russ. Phys. Chem. Soc.*, xxxix. 307; *C. A.*, i. 1774. R. T. Thompson and H. Dunlop, *Analyst*, xxxi. 281; *C. A.*, i. 70. H. Loomis, *Chem. Eng.*, v. 205; *C. A.*, i. 1475. A. P. Laurie, *J. Roy. Soc. Arts*, lv. 557; *C. A.*, i. 1475. Utz, *Chem. Rev. Fett-Harz-Ind.*, xiv. 137; *C. A.*, i. 2181. L. E. Levi and E. G. Wilmer, *A. L. C. A. J.*, ii. 164; *C. A.*, i. 2944. W. Fahrion, *Z. angew. Chem.*, xxi. 1134, 1219; xxiii. 722; 1106; *C. A.*, ii. 2312, 2458; iv. 2882, 2883. E. Lorentz, *Chem. Ztg.*, xxxii. 819; *C. A.*, ii. 3159. J. Desalme, *Rev. chim. ind.*, xx. 233; *C. A.*, iii. 2387. E. Collin, *Ann. chim. anal. appl.*, xiv. 256; *C. A.*, iii. 2840. O. Eisenschiml and H. N. Copthorne, *J. Ind. Eng. Chem.*, ii. 28; *C. A.*, iv. 679. Estor, *Matières grasses*, iii. 1669; *C. A.*, iv. 1108. T. A. Davidson, *Papers, Paint and Varnish Soc.*, 1908-1909; *Matières grasses*, 1908, 1271; 1909, 1349; *C. A.*, iv. 1108; iii. 1095. M. B. Blackler, *Paint and Var. Soc.*, 1908-1909; *C. A.*, iv. 1109. W. E. F. Powney, *Analyst*, xxxv. 192; *C. A.*, iv. 2581. J. Hertkorn, *Chem. Ztg.*, xxxiv. 462;

- C. A., iv. 2743. W. Lippert, *Rev. Fett-Harz-Ind.*, xvii. 215; C. A., iv. 3143.
- Mastic. L. E. Andés, *Rev. Fett-Harz-Ind.*, xiv. 190; C. A., i. 2750; ii. 189.
- Ochres. O. Coffignier, *Rev. chim. ind.*, xviii. 289; C. A., ii. 592. J. C. Stoddard and A. C. Callen, *U. S. Geol. Sur. Bul.* 430G, 5; C. A., iv. 2082.
- Oil, Paint, and Varnish Problems. A. P. Laurie, *Oil Color J.*, xxxii. 1758, 1973; xxxiii. 59, 189, 353, 599; C. A., ii. 1623-1624, 2020-2021. A. Livache, *Compt. rend.*, 146, 898; C. A., ii. 2021. M. A. Tixier, *Mon. Sci.*, Oct., 1906, 726; C. A., i. 491.
- Oil bleaching. A. Metz and P. L. Clarkson, *Les corps gras ind.*, xxxiv. No. 1; C. A., ii. 194.
- Paint, analysis. J. E. Thomsen, *J. Am. Chem. Soc.*, xxviii. 1602; C. A., i. 490. Anon., *Oil Color J.*, Mar. 25, 1905; C. A., i. 491. W. I. Keeler, *J. Ind. Eng. Chem.*, ii. 388; C. A., iv. 3305.
- Paint, for cement. C. A., i. 1764. Edit., *Chem. Eng.*, vii. 206; C. A., ii. 2308.
- Petroleum ether. J. Marshall, *Am. J. Pharm.*, lxxix. 315; C. A., i. 2289. Holde, *Mitt. Kgl. Materialprüfungsamt, Gross Lichterfelde West*, xxvii. 143; C. A., iv. 664.
- Polymerization of drying-oils. S. A. Fokin, *J. Russ. Phys. Chem. Soc.*, xxxix. 308; C. A., i. 1775.
- Poppy-oil. L. Vuafart, *Ann. falsifications*, ii. 276; C. A., iii. 2391.
- Pyroxyline. G. Lunge, *Z. angew. Chem.*, xxix. 2051; C. A., 908.
- Resin acids. J. Marcusson and G. Winterfeld, *Rev. Fett-Harz-Ind.*, xvi. 104; C. A., iii. 1696. K. Dieterich, *Rev. Fett-Harz-Ind.*, xvi. 137; C. A., iii. 2062.
- Rosin. Paul Levy, *Ber.*, xxxix. 3043; xlii. 4305; C. A., i. 54; iv. 454. C. Schwalbe, *Wochbl. Papierfabr.*, xxxviii. 1303; C. A., 2635. Vezes, *Proc. verb. soc. phys. nat. Bordeaux*, 1905, 75; C. A., i. 2638. C. Bachem, *Arch. exp. Path.-Pharm.*, lvii. 222; C. A., i. 2802. M. W. Shkatelov, *Mon. Sci.*, xxii. 217, 548; C. A., ii. 1714, 2872. F. Schulz, *Rev. Fett-Harz-Ind.*, xvi. 186; C. A., iii. 2512. Estor, *Matières grasses*, iii.

- 1669; *C. A.*, iv. 1108. M. Utz, *Mon. sci.*, Oct., 1906, 761; *C. A.*, i. 491. S. Leskiewicz, *J. prakt. Chem.*, lxxx. 403; *C. A.*, iv. 2284.
- Sandarac. A. Tschirch and Max Wolff, *Arch. Pharm.*, ccxlv. 684; *C. A.*, i. 1165.
- Saponification. J. Lewkowitsch, *Ber.*, xxxix. 4095; *C. A.*, i. 492. F. Marx, *Chem. Ztg.*, xxxiv. 124; *C. A.*, iv. 1389. O. Schutte, *Chem. Ztg.*, xxxiv. 351; *C. A.*, iv. 1814. E. Rupp and F. Lehmann, *Apoth. Ztg.*, xxiv. 972; *C. A.*, iv. 1910.
- Shellac. Welwart, *Chem. Ztg.*, xxxi. 143; *C. A.*, i. 1065; Committee A. C. S., *J. Am. Chem. Soc.*, xxix. 1221; *C. A.*, i. 2748. P. C. McIlhiney, *J. Am. Chem. Soc.*, xxx. 867; *C. A.*, ii. 1896. Ahrens, *Z. öffentl. Chem.*, xiv. 463; *C. A.*, iii. 959. A. F. Suter, *J. Roy. Soc. Arts*, lvii. 660; *C. A.*, iii. 2631. Anon., *Chem. Ind.*, xxxiii. 455; *C. A.*, iv. 2743.
- Soya bean. G. Ruata and G. Testoni, *Boll. uff. minis. agr. ind. com.* [Rome], vi. 698; *C. A.*, ii. 864. W. B. Cowie, *Pharm. J.*, lxxxiv. 403; *C. A.*, iv. 1552.
- Spontaneous combustion tests. A. H. Gill, *J. Soc. Chem. Ind.*, xxvi. 185; *C. A.*, i. 1476.
- Sunflower-oil. L. Bock, *Farb. Ztg.*, xiii. 51; *C. A.*, iii. 250.
- Turpentine. G. B. Frankforter, *J. Am. Chem. Soc.*, xxviii. 1461, 1467; xxxi. 561; *C. A.*, i. 57, 103; iii. 1817. C. D. Holley, *17th Rep. N. Dak. Agr. Exp. Sta.*, Pt. II. (1906); *C. A.*, i. 486. P. Klarson and H. Person, *Papier Ztg.*, xxxii. 4; *C. A.*, i. 1320. Anon., *Eng. News*, lvii. 317; *C. A.*, 1619. M. Dubroca, *J. chim. phys.*, v. 463; *C. A.*, ii. 934. J. E. Teeple, *J. Soc. Chem. Ind.*, xxvi. 811; *C. A.*, ii. 1041; *J. Am. Chem. Soc.*, xxx. 412; *C. A.*, ii. 3126; *J. Ind. Eng. Chem.*, i. 597; *C. A.*, iv. 1803. W. C. Geer, *Forest Service, U. S. Dept. Agr., Circ.* 114, 152; *C. A.*, ii. 1041; iii. 382. C. Harries and H. Neresheimer, *Ber.*, xli. 38; *C. A.*, ii. 1139. H. Herzfeld, *Rev. Fett-Harz-Ind.*, xv. 11; *C. A.*, ii. 1185. A. McGill, *J. Soc. Chem. Ind.*, xxvi. 847; *C. A.*, ii. 1881. C. H. Herty, *J. Am. Chem. Soc.*, xxx. 863, 872; *C. A.*, ii. 1881; iii. 2379; *J. Ind. Eng. Chem.*, i. 68; *C. A.*, iii. 1468. W. Flash, *Farb. Ztg.*, xiii. 78; *C. A.*, ii. 1882.

- O. Kress, *Sch. Mines Quarterly*, Nov., 1907; *C. A.*, ii. 1882. A. Tschirch *et al.*, *Mon. Sci.*, xxii. 376; *C. A.*, ii. 2307; *Arch. Pharm.*, ccxli. 1, 156; *C. A.*, ii. 1275, 1448. F. W. Richardson and J. L. Bowen, *J. Soc. Chem. Ind.*, xxvii. 613; *C. A.*, ii. 2872. E. Darmois, *Compt. rend.*, cxlvii. 195; *C. A.*, ii. 3190. L. E. Walburn, *Stat. Ser. Inst. Kopenhagen, Pharm. Centr.*, xlix. 912; *C. A.*, iii. 251. I. Schindelmeiser, *Chem. Ztg.*, xxxii. 8; *C. A.* iii., 382. R. Adan, *Bul. soc. belg. chim.*, xxii. 389; *C. A.*, iii. 382. A. E. Paul, *J. Ind. Eng. Chem.*, i. 27, 261; *C. A.*, iii. 712, 2375. G. Roos, *Rev. Fett-Harz-Ind.*, xvi. 32; *C. A.*, 954. Vezes, *Proc. verb. soc. phys. nat. Bordeaux*, 1905, 123; *C. A.*, i. 2530; *Compt. rend.*, cl. 698; *C. A.*, iv. 1665; *Ann. fals.*, iii. 265; *C. A.*, iv. 3143. L. Clement, *Mat. grasses*, ii. 1565; iii. 1670; *C. A.*, iv. 106, 1098. E. Darmois, *Compt. rend.*, cxlix. 730; *C. A.*, iv. 583. Mansier, *Repert. pharm.* [3], xxi. 434; *C. A.*, iv. 950, 1098. O. Higman, *Elec. World*, lv. 404; *C. A.*, iv. 995. J. Marcusson, *Mitt. Kgl. Mat., Gr. Lichterfelde W.*, xxvi. 157; *C. A.*, iii. 834; *Chem. Ztg.*, xxxiii. 285, 966, 978, 985; *C. A.*, iv. 1236, 1542, 1803; *Rev. Fett-Harz-Ind.*, xvii. 6; *C. A.*, iv. 1541. G. F. Richmond, *Philipp. J. Sci. (A)*, iv. 231; *C. A.*, iv. 1236. H. North, *Ann. Rep't of Lehn & Fink*, 1909; *C. A.*, iv. 1350. P. Nicolardot and L. Clément, *Compt. rendus*, cxlix. 572; *C. A.*, iv. 1368; *Bull. soc. chim.* [4], vii. 173; *C. A.*, iv. 2040. R. S. Morrell, *J. Soc. Chem. Ind.*, xxix. 241; *C. A.*, iv. 1664. F. A. Asplund, *Apoth. Ztg.*, xxv. 295; *C. A.*, iv. 1894. J. H. Coste, *Analyst*, xxxiii. 387; xxxiv. 148; xxxv. 112; *C. A.*, iii. 116; iv. 1905, 2202. G. Vavot, *Compt. rend.*, cl. 1127; *C. A.*, iv. 2097. C. T. Kingzett and R. C. Woodcock, *J. Soc. Chem. Ind.*, xxix. 791; *C. A.*, iv. 2982. C. Grimaldi, *Chem. Ztg.*, xxxiv. 721; *C. A.*, iv. 4005. O. Fernandez, *Rev. real. acad. cien.*, viii. 63; *C. A.*, iv. 960. E. Louise, *Compt. rend.*, cl. 526; *C. A.*, iv. 1368. W. Vaubel, *Z. angew. Chem.*, xxxiii. 1165; *C. A.*, iv. 2883. A. Eibner and O. Hue, *Chem. Ztg.*, xxxiv. 643; *C. A.*, iv. 3134.
- Ultramarine. E. R. Andrews, *Analyst*, xxxv. 157; *C. A.*,

- iv. 2049. J. Hoffmann, *Chem. Ztg.*, xxxiv. 821; *C. A.*, iv. 3046.
- Ultraviolet light. K. Hahn, *Z. angew. Chem.*, xxi. 1637; *C. A.*, iv. 2750.
- Varnish. M. A. Tixier, *Mon. sci.*, Oct., 1906, 726; *C. A.*, i. 491. L. E. Andes, *Rev. Fett-Harz-Ind.*, xiv. 76; xvii. 101; *C. A.*, i. 1909; iv. 2384. A. Livache, *Compt. rend.*, cxlvi. 898; *C. A.*, ii. 2021. Committee, *Farben Ztg.*, xiii. [26], *C. A.*, ii. 2163. P. C. McIlhiney, *Chem. Eng.*, viii. 70; *C. A.*, ii. 2630.
- Varnish, reviews. M. Guedras, *Rev. gén. chim.*, x. 93; *C. A.*, i. 1328. M. Bottler, *Rev. Fett-Harz-Ind.*, xiv. 115, 139, 165, 186, 213, 245; xv. 108, 136, 161, 195, 221, 279, 303; xvii. 73, 102; *C. A.*, ii. 190; iii. 493; iv. 1908. C. Coffignier, *Rev. chim. ind.*, xix. 319; *C. A.*, iii. 1470.
- Whitewash, waterproof. Edit., *Rock Products*, viii. 28; *C. A.*, ii. 2439.
- Wood-oil, Chinese. A. Guiselin, *Mat. gras.*, iii. 1689; *C. A.*, iv. 1908. A. Kreikenbaum, *J. Ind. Eng. Chem.*, ii. 205; *C. A.*, iv. 2049. E. W. Boughton, *J. Soc. Chem. Ind.*, xxviii. 719; *C. A.*, iv. 2049.
- Zinc. E. W. Buskett, *Eng. Min. J.*, lxxxiii. 760; xc. 502; lxxxv. 812; *C. A.*, i. 1627; ii. 2350; iv. 3057; *Mines and Minerals*, xxviii. 183, 193; *C. A.*, ii. 645, 592. W. F. Gordon, *Eng. Min. J.*, lxxxiii. 1033; *C. A.*, i. 2035.

APPENDIX II

CROCKETT'S VARNISH FORMULAS

APPENDIX II

CROCKETT'S VARNISH FORMULAS

INTRODUCTION

THIS book was written in 1867 by Charles F. Crockett, a nephew of the original David B. Crockett, and was sold in that year to Stoddard & Co., of Dayton, Ohio. On the purchase of their business by H. C. and H. Lowe, the book passed into their possession (1872). In 1909, by the courtesy of Mr. Houston Lowe it was given to me for publication.

Although these formulas are now obsolete, they must be of deep interest to all varnish-makers; Crockett was the inventor of the American varnish-kettle and fireplace, and modern American practice is based on his work.

This was a holographic manuscript, never printed until now, and the thanks of the varnish public are due to Mr. Lowe for its preservation and publication.

A. H. S.

Remarks.—Cans for varnish should have two faucets: one at the bottom, or say within 3 inches of the bottom, and one half-way up.

All cans of varnish, etc., should be drawn and poured over, after being filled at any time.

If in cooking a batch of japan, etc., you don't get it thinned down the same day, break away the head before you leave it, as the heat may increase of itself and cook it too much, or boil over.

As all baking japans are made much brighter by the use of benzine in reducing them, it is worth a trial in all varnishes, etc., say $\frac{7}{8}$ turpentine and $\frac{1}{8}$ or more benzine. Always add the benzine last. All baking varnishes or japans must have in either Benguela or Zanzibar gum.

In cooking all oils, japans, etc., you should have the lid handy, in case of fire. Also a pail of oil, which can be used to cool off the batch on the fire (same kind of oil as in the batch); also a pail of water and a brush, to cool off the kettle when too hot. Sand thrown on the lid will smother it out, or a wet bag is good.

In adding lead and litharge to gum and oil, simply united, and which you wish to cook more, there should be no froth or head on the batch at the time you add them.

All measures should be drained in box, and not on top cans; say a box and measures for dark work, and the same for light work.

If some method could be used to refine the asphaltum, get the dirt out by melting it and letting it settle, and then remelting it. The plan is valuable and simple.

The head, while cooking the brown baking japan and enamel top finish, etc., can be kept say 4 or 5 inches thick for any kettle used.

In all cases where a certain degree of heat is wanted use a thermometer.

All driers, such as lead, litharge, and manganese, should be well dried, over a slow fire, and then used. Five minutes is long enough time to occupy in adding any of these or any other drier while making up a receipt.

If you cook pill too hard in japan drier (for a drier for paints), they will not mix with raw oil, and can not be sold so well. And if cooked too hard, in the baking japans, the japan will run in drips from the work while baking it.

At the time the gum is melted, the oil must be at its proper heat.

If you cook the pill too much in the enamel top finish, the finish will work tough, and won't flow as well.

All packages when sold should be distinctly labelled as to quality, etc., and all goods manufactured should have their proportions and methods of making in a book dated and kept for that purpose.

Take a note of how all goods sold were made, so a customer can have the same next time.

In taking lid from batch of gum and oil, be careful not to do it too quick, or let a draught of air too strong, to blow

across it at that time. In a minute or so there will be no danger.

When you have benzine to add, commence to reduce as hot as you can, as benzine doesn't go in so well if the batch has cooled off some.

Benzine and naphtha mean the same thing; although naphtha is not mentioned at all, yet it is so known in the market.

Any japan, etc., with asphaltum in it needs no straining, and in anything where you use asphaltum a small amount will give you a chestnut color, and more a brown and black.

Reduce all baking japans to the substance of stout furniture varnish.

All oils should settle until they are clear and brilliant before using them.

Keep the outside of the gum-kettle warm or hot if you can while melting.

If you want the varnish to dry harder at any time, use Benguela or Zanzibar gum, if you are using kauri-gum. This will apply to any varnish, etc., of course keeping in view that you don't use a gum at a price higher than you can sell the varnish for. If you want a higher-priced varnish at any time, then use a better gum, and *vice versa*.

All benzine should be of 62 gravity, unless ordered otherwise, and always test the gravity before using it.

All kettles should be on wheels, say 8 inches in diameter, allowing the two front ones to turn under a curve, or gooseneck, so that they can be turned short around, and if the floor of the factory is level with the fireplace no truck is needed.

The construction of the fireplace should be nearly the diameter of the gum-kettle, and the kettle should rest within 3 inches of the fire, within a circular arm-band, made to fit the kettle, and an adjustable rim can be placed on this rim so it will fit one or two sizes of kettles.

Iron kettles must be used for making japans, etc., and commonly called agricultural kettles.

The fireplace is simply a circle made in the floor, beneath the centre of the chimney, say 8 or 10 inches deep, with a draught-hole underneath, by which the fire is regulated.

Manganese-oils should be kept from the light until they are used; and they are stronger if used say within a week or so at the furthest after they are made; and no oil should be kept more than 30 days, as they soon begin to grow fatty and then lose some of their drying qualities.

The best method of adding turpentine is to place a vessel, with a faucet attached, running through a small fire-proof walled room, by which the fluid may be drawn at will. The distance from the fireproof or turpentine room to the fireplace should be at least 40 to 50 feet.

The chimney where all the cooking is done should be say 30 to 60 feet high, and from 6 to 12 feet square at the base (in the clear) and tapering to the top. The construction of such a one a competent mason can do. A gently slanting archway should extend from one of the sides of the chimney, say some 15 feet, with proper doors at its entrance, which would be better if fireproof.

All varnishes, especially the "wearing body" and the spirit varnishes, and the "car inside," should be made on a clear day. The common kinds are not of so much consequence.

All kettles for melting gums should be of copper, and the sizes and shapes can be found out from those who make them in New York City and elsewhere; the largest melting 100 lbs. of hard gum, such as Benguela or Zanzibar, and 140 lbs. of soft, such as kauri, North Coast, etc.

Gum to be well melted should run off the rod or stirrer about as freely as water, when dipping the stirrer in and looking at it; whipping down the head until this result is produced.

All oils should be added to the gums with the kettle off the fire.

If while making anything you cook it too much and it seems to decompose, at this particular time add some fine powdered rosin, slowly, and it will bring it back all right, so it can be used for a second quality of what you are making. The amount for a batch of varnish should be say 6 to 8 lbs. and so on.

The construction of the rods and stirrers can be found out from those acquainted with the business, and can be better seen than described.

All varnishes, japans, etc., should be kept after they are made in a temperate or warm room (except the spirit-varnishes, which should be kept below temperate). All oils prepared should be kept some above temperate, as soon as they are prepared.

Where two kinds of gum are used they must be melted separate, and mixed warm after made; and all varnishes, japans, etc., should be reduced to their proper substance at the time they are made, if possible.

All varnishes should be well strained through a double flannel strainer, and any combination of varnish and other fluids should be well stirred together. This applies to oils, driers, etc.

All packages should be washed out with clean turpentine before putting fine varnishes in them; also, all cans when sold should be sealed, after being well cooked, with plaster-of-paris.

These rules, although so simple, will save much trouble if properly carried out.

All driers should be well dried before being used and care should be taken to get the best articles of all kinds.

Oil-kettles should be cleaned before using them and they should be made of iron.

There should be a separate fire for heating oils to be added to gum, etc., and the oil must be at its proper heat when the gum is melted.

It is nothing new to melt the gum in the oil and then reduce; but it is slower and the yield is so much less, and costs more, and doesn't make quite as good varnish, so I don't put the process in here, but will at any time explain it; or anything else, old or new, not in here.

An apparatus for condensing the vapor from turpentine while you are reducing, and carrying it so condensed back into the kettle you are reducing, would be a great saving of turpentine, and very simple.

All oils and japans, etc., should be left to settle over night in the kettle they are made in, and partially covered,

as they settle quicker when kept warm. Varnishes should be put into cans as soon as reduced.

Make a small amount only of any of the within recipes, until you become accustomed to the process.

By warming varnishes, etc., over, a few days after they are made, and restraining them, it will ripen them very much. But be careful of the fire when you do it.

The best fuel to use is good coke

Melted gums yield as follows:

Zanzibar.....	5	gals.	to	each	100	lbs.
Benzuela.....	5	"	"	"	"	"
North Coast.....	4	"	"	"	"	"
Kauri.....	7	"	"	"	"	"

Bleached-oil.—Is made as follows: Put any number of gallons of best American linseed-oil in a clean iron kettle and place it over a good fire, and heat it to 490° , and keep the heat so for 5 minutes, and then draw the kettle from the fire and let it cool down to say 250° . Then put away in cans in a warm place; the oil can be used next day. Stir every few minutes while it is heating up, and if any scum rises skim it off. A kettle of 120 gals. capacity can bleach say 80 gals. of oil, or two-thirds full. This rule of capacity should be observed in cooking all oils, japans, etc.

Purified Manganese.—Is made as follows: Take a clean ordinary water-pail, and put it half full of black pulverized oxide of manganese (ground about as fine as gunpowder); now fill the pail full of clean water and stir it well up together. Let it stand still for 7 minutes, then pour off the water carefully. Repeat this twice more, but the second time let the water stand on it for 4 minutes, and the third or last time for 2 minutes. Then dry the manganese by a slow fire, stirring it all the time, on a piece of sheet-iron, or in the sun, and store away for use. The kind that is of a greenish color (German) is the best. After the manganese has been used once it is of no further use, only to make black paint of. Buy that which has the most oxygen in it.

No. 1 Manganese-oil.—Is made as follows: Place in a clean iron kettle say 80 gals. of the bleached oil and heat to 325° slowly, and then add 30 lbs. of the purified manganese, sprinkling it in the oil slowly. Now slowly in-

crease the heat to between 325° and 340° , and stir the whole from the bottom from first to last slowly and steadily. After you put the manganese in keep the heat as above for 4 hours and then remove the kettle from the fire and stir for half an hour more; then store away in cans while yet warm. Can use in 5 days—bail off the top as you use it, and so on down till all used up. A lighter but a slower drying-oil can be had by cooking it a shorter time. Be sure the manganese does not burn on the bottom of the kettle while cooking it. Although this oil when done should be a very light color, yet it should have a very slight tinge of brown. If it has not, then stir it slower (the next time) as the brown color makes it dry, by reason of the oxygen in the manganese being disengaged. You can by not stirring quite so often get the same result some sooner; but 4 hours is about right. If you can get the manganese pure you can use it not purified (in this oil or the No. 2 manganese), but it will take a good while to settle, say 6 or 8 days.

Umber-oil No. 1.—Is made as follows: Observing the rule of capacity (given under "Bleached-oil"), cook any number of gallons up to 150 (but 80 gals. handle very well; where so large an amount of oil is to be cooked some machinery will be needed to keep so large an amount of red lead from burning fast on the bottom of the kettle; as it would stir very heavy, and almost impossible by hand-power). However, to proceed: to each gallon of bleached-oil add $\frac{1}{4}$ lb. of red lead and $\frac{1}{4}$ lb. of roasted turkey umber, size of white walnuts; first heating the oil to 325° . Place the umber in a wire basket, just below the surface of the oil, when at the above heat. Sprinkle the lead in slowly. From 325° increase the heat to 450° , increasing it equally for 4 hours, and then cook 1 hour more at the same heat, making 5 hours in all. Stir the lead very often from the bottom to keep it from burning. When the 5 hours or so are up, the batch will be nearly all headed over; and then while it cools some, and while yet warm, put it away in cans for use. The umber is good to use only once, and the lead will nearly all melt. The first hour, or hour and a half, after the lead is in, the oil should be well stirred until it

is clear and transparent, or nearly so, on a piece of glass. Can be used in 3 or 4 days, or next day if needed, using it from the top; better use in 10 days.

To roast the raw turkey umber, dry it slowly till brown, over a slow fire, stirring it well in mean time.

Furniture-oil.—Is made as follows: Observe the same rules, as to heats and time of cooling, as in the umber-oil; but to each gallon of oil use $3\frac{1}{2}$ ounces of red lead and $3\frac{1}{2}$ ounces of litharge, and $\frac{1}{2}$ ounce pulverized black oxide of manganese (purified), all mixed together dry and sprinkled in the oil slowly. All other rules the same. This can be used in about the same time as the umber-oil. Stir this well the first half-hour after the lead, litharge, and manganese are put in. Note—all heats should be brought up gradually. This oil when done will be nearly all headed over, and when cooled to a temperate heat must be as stout as sugar-house molasses. If it is not, you cannot put in the 30 to 32 gals. of turpentine in the No. 1 furniture-varnish, etc.; for the stouter the oil is the more spirits it will carry, and *vice versa*. But have the thickness so that by melting the gum as described, you can get in only 30 to 32 gals. of spirits, as more than this would be a detriment to the varnish. Of course if the oil is not stout enough, you must cook it longer the next time, as described, and *vice versa*. Stir often but gently from the bottom, to keep the driers from burning and darkening the oil.

Magnesia-oil.—Is made as follows: 30 gals. of the oil is enough to do, as the use is quite limited; or even a smaller amount will do. To this amount of bleached oil when it is heated in an iron kettle to 375° or 400° , add $1\frac{1}{2}$ lbs. of best calcined magnesia; stir all the while you are sprinkling it in, and for 1 hour after, at the above heat. Then remove the kettle from the fire, and stir for twenty minutes or half an hour more, and as soon as cooled to 250° put in cans for use. Can use in about 15 days. Stir the magnesia in very steadily while you are adding, as well as after it is in, till done.

No. 2 Manganese-oil.—Is made as follows: Use the purified manganese for this, 5 ounces for each gallon of oil; cook all through, as in the No. 1 (but the heat is to be at

350°), and in this case stir the oil every time the bubbles have continued for half a minute; *viz.*, while the bubbling is going on don't stir it any, but when the half-minute is up, stir it well from the bottom for a few seconds, then let it bubble again, and so on for 5 hours, or until the oil is between the color of pale and dark brandy (the nearer you get it to the brandy color the quicker it will dry); then cool and store away in a warm place. If the oil in 5 hours is not color, then don't stir quite as often the next time. Can use in 5 days.

Benzine Shellac-oil.—Use same rules as in the furniture-oil, but use only half the amount of red lead and litharge, and no manganese. Can use in about the same time.

Lithographers'-oil.—This amount of oil is enough, as the sale is limited, and the process not so safe in large amounts. Put 10 or 15 gals. of bleached oil in a small iron kettle (straight at the sides), not over half full, and place it over a good fire, and get it hot enough to set fire to the top of the oil. As soon as it has burned, say 3 to 5 minutes, put lid on and smother it out. Repeat this 6 or 8 times, and then cool and store away for use or sale. If the oil is not thick enough, then set fire to it afterward, as different substances are required. And if you want a slow-drying oil, don't fire at all, but boil it middling thick, at say 480°. And if to dry a little, fire a little. Can sell as soon as done. The oil must be off the fire when you set fire to it, or what is called firing it, or burning it.

Umber-oil No. 2.—Is made as follows: Take say 80 gals. of the bleached oil and heat it to 325°, and then put 25 lbs. of roasted turkey umber in two separate wire baskets, half in each, and hang them just below the surface of the oil; and increase the heat gradually to 450° for 5 hours' cooking. The oil will need no stirring while cooking. Use in 5 or 6 days.

Thick-oil.—Is made as follows: Heat say 80 gals. of the best American linseed-oil to 480° and keep it so for 4 hours, stirring it occasionally from the bottom; then let it cool down, say to 250°, and put away in a warm place, in cans for use. Can use in a day or two. I call it thick-oil simply to give it a name.

Important Note.—For all purposes where No. 1 manganese-oil is called for, you can use No. 2 manganese-oil and thick-oil, mixed at the same time you use them, and it will do as well. I don't see any difference. You can mix them in any proportions you choose. The more thick-oil you have the lighter will be your varnish, but it will dry some slower. Mix them so the color will be as light as you can afford to have it and dry quick enough to suit you. If the oil dries too quick, so mixed, or if the No. 2 manganese alone is used, then the varnish will crawl some. In coach work, taking the No. 1 manganese at a certain brown color (which color is its drying quality), or mixing the No. 2 manganese with the thick-oil until you get the same color, I cannot see much difference; but I think the two mixed is the handiest. However, by mixing the two you can get an oil of a lighter color, that will dry as well as a lighter shade of the No. 1; as the No. 2 manganese acts as a drier for the bleached oil, when mixed with it.

Wearing Body, or Imitation English Varnish, is composed of 100 lbs. best Zanzibar gum; 35 gals. No. 1 manganese-oil (or the No. 2 and thick-oil mixed); 37 gals. (*about*) of camphine;* and is made as follows: As soon as the gum is well melted have the oil ready at say 350°, and add it to the gum, the kettle now off the fire, but the lid on the gum-kettle; add the oil through a funnel placed in the lid of the gum-kettle (near the edge). This kettle use for melting all gums. Add the oil slowly, a small stream at first and increase it as you proceed. Stir it well in, and after it is in, for 2 or 3 minutes. Then take lid from the kettle carefully and cook the batch by removing it off and on the fire, so you keep a head all the time on the batch, 2 or 3 inches deep till done. And when done, by placing some on a piece of glass, it will when placed in contact with the point of a knife-blade (for instance), and extending the blade, the substance will string a fine unbroken thread, say 12 to 18 inches long; the substance should cool a little before you can produce the result of the stringing out. This result being produced, let the batch cool off for say $\frac{1}{4}$ hour, or

* Camphine was redistilled spirit of turpentine.—A. H. S.

until you can almost see the clear varnish; stir down the head some in mean time. Then add the camphine slowly, a small stream at first, and stir well in as soon as batch will permit, as is required in reducing all hot substances. This can be sold for cars in say 2 months, but for coaches, etc., it should be kept for 4 to 6 months. Store away in warm place. Keep the kettle all the time partially over the fire if you can, is better.

Liquid Zinc Drier, cheaper and nearly as good, is composed of 20 gals. bleached oil; 20 lbs. pulverized black oxide of manganese (purified). Put the manganese in at 250° and cook to pill, and add 25 gals. turpentine. In saying cook to pill, I should say a very soft one, or like stout bread dough; or a little short of a pill.

Turpentine Dammar is composed of 100 lbs. best dammar-gum; 18 gals. turpentine, or 20 gals. for a thinner article; and is made as follows: Put the dammar in a clean gum-kettle and add to it 8 gals. of the turpentine, and put it over a small charcoal fire and stir it, and as soon as vapor begins to rise put the lid on and take from the fire; then lid off and stir; then lid on and on the fire, and lid off, and so on till all melted. Then add balance of the turpentine. Rosin is put in the dammar to cheapen it, but is a bad article to sell. Can sell in a day or so. Some prefer to put dammar and turpentine in an open barrel and stir them till all is dissolved—it is all done cold, no fire. Three lbs. sulphate of zinc. to each 100 lbs. dammar, added as soon as dammar is reduced, will harden it very much. Pound well the zinc and well dry it over a slow fire before adding it. When the zinc is used the dammar must be made with the fire. If it could be made by putting the dammar and turpentine all in a water-bath, the water kept boiling all the time and the kettle set into it and covered up, then as soon as melted add the zinc, it would be better. If the vessel for melting the gum in a water-bath could be of glass, the dammar would be much lighter colored.

Benzine Dammar is composed of 100 lbs. best dammar-gum; 8 gals. turpentine; 12 gals. benzine; and is made as follows: Cook same way as turpentine dammar, but add the benzine last by itself after the turpentine and dammar

are well united. Add it slowly and stir it well in. Can sell in a few days. It can be made all benzine, 100 lbs. dammar and 17 gals. benzine (65 gravity) stirred up in a barrel cold till all dissolved, yet if made in summer it will do; but made in cold weather it is very apt to separate.

Pure Shellac is composed of 30 gals. best alcohol; 60 lbs. shellac (Campbell's or native), or 75 lbs. for a thicker article; 4½ gals. turpentine varnish; and is made as follows: Put the shellac and alcohol in an open barrel and stir occasionally till all dissolved. Then stir in the turpentine varnish. Can be made over a slow fire by being very careful. Can sell soon as done.

No. 1 Harness is made as follows: Make the same as the pure shellac, but leave out half the turpentine varnish and use it with some of the pure shellac, with 5 lbs. of best lampblack made in a fine paste, and if not thin enough to pour easily add some turpentine, and so stir it well into the pure shellac (use equally of pure shellac and turpentine varnish). When you mix the lampblack mix them thoroughly together and grind fine, say in a hand-mill. Can sell as soon as done.

No. 2 Harness is the No. 1 trunk, as in next formula, with to 40 gals. of it, say 6 lbs. best lampblack, well stirred in, in a paste, made with some of the varnish and prepared as in No. 1 harness. Can sell as soon as made. Use the mill for the lampblack as in No. 1, is better.

Imitation Shellac, or Spirit Shellac, or Brush Shellac, or No. 1 Trunk (Clear) is composed of: 20 gals. best alcohol; 26 gals. benzine (62 gravity); 150 lbs. light rosin; 100 lbs. kauri dust; 5 lbs. brown sugar of lead; and is made as follows: Dissolve the dust in the alcohol in an open barrel, as in the pure-shellac case; then melt the rosin and add the sugar of lead and cook one hour; first pound fine and well dry the lead; then reduce with the benzine and unite both batches in another kettle, over a warm fireplace (the fire all out); unite them equally and slowly and stir well in. Can sell as soon as done. A harder article can be made, costing some more, by taking 100 lbs. rosin and 100 lbs. kauri dust, 20 gals. alcohol and 20 of benzine, all rest of rules the same. And a No. 2 is made by melting 150 lbs. rosin,

cooked same way, lead on it, and add 8 gals. No. 1 coal-tar naphtha and 20 of benzine (62 gravity), and mixing this with the No. 1 trunk, as to price you wish to sell for. The above of Nos. 1 and 2 can be reduced if too thick with the following mixture: 1 part alcohol, 2 parts benzine (62 gravity), and 2 parts coal-tar naphtha. By being very careful, as in making turpentine dammar, you can put the articles all in a clean copper kettle and melt them all at once and complete the batch then; but have a very small fire. This care is very necessary. But the safest way is to make it cold, as before described. Yet it takes a much longer time to do it. Some very hot sand away from any fire and set the kettle on that, will melt it all safely. Change the sand to keep it hot till all is done; or if set in boiling water and the water kept boiling it will do much better. These shellacs are better the more dust and less rosin you use, of course costing some more. Some rosin must be used, say $\frac{3}{4}$ dust and $\frac{1}{4}$ rosin is the best; the mixing process is as before described. The proportions as given of alcohol and benzine are the limit to benzine to have it hold well together, but less or more rosin goes easily enough; but where you do so you will of course have more or less benzine, consequently the varnish will be too thick or too thin, unless you use less dust to each gallon of alcohol or less rosin to less benzine, and *vice versa*, all the way through. All spirit varnishes should be strained through some curled hair placed in mouth of funnel, the hair washed out as soon as done. Can use 1 gal. turpentine to 8 gals. alcohol, mixed in the alcohol before using it; it cheapens the alcohol and is just as good.

Benzine Shellac is composed of 100 lbs. picked kaurigum; 8 gals. benzine shellac-oil; 4 lbs. red lead; 8 gals. turpentine; 22 gals. benzine (62 gravity); and is made as follows: Add the oil to the gum when melted, at say 325° ; then, as soon as you can, take the lid from kettle and add the lead slowly and cook as in gum japan-drier, to a moderate pill, and reduce, first with the turpentine and then with the benzine. Be careful of fires around the place, and cook about strong enough to take the reducing and no more. This is a quick filling for wood, and the No. 1 trunk is also

sold for the same purpose. Always in reducing, especially with benzine, have the fires all out around you, or at least be safely away from them, especially on a damp day.

Black Walnut Stain is simply the No. 1 air-drying asphaltum, reduced with turpentine to the substance you want; but it is also sold full substance, and they reduce it themselves.

Rosewood Stain is composed of 1 gal. alcohol; 2 lbs. logwood chips. Steep this cold, taking 3 or 4 days to do it, and strain and press it out. Then to 1 gal. of alcohol add 4 lbs. of the extract of logwood and dissolve this; and color this to suit the color you want; or red sanders-wood will do, but not as well.

Gold Size, for laying on gold-leaf, is composed of 18 gals. furniture-oil; 12 lbs. litharge; 5 lbs. best Burgundy pitch; 5 gals. hard drying furniture-varnish; and is made as follows: Heat oil to 325° and add litharge slowly, and cook till clear. Then add the pitch and cook to soft pill, and cool and add the varnish first and then the turpentine.

Flock Size, for flocks on wall-paper, is the same as gold size, but use rosin instead of pitch.

English Patent Drier is composed of 1 gal. furniture-oil; 3 gals. turpentine; thicken to the substance you wish with equal parts of Paris white, dry zinc, and barytes, and grind all in a mill fine.

Gold Lacquer is composed of 1 lb. shellac; $\frac{1}{2}$ lb. gum sandarac; $\frac{1}{2}$ lb. soft turpentine; $\frac{1}{2}$ gal. alcohol. Dissolve this as in pure shellac, all together, and make separate solutions of gamboge and turmeric and alcohol, and color the above to suit.

Heddle-varnish—for cotton-mills—the thread in the looms—is composed of 10 lbs. best shellac; 30 gals. umber-oil No. 2; 45 gals. turpentine; 30 lbs. red lead; and is made as follows: Heat the oil to 325° , and add the lead, and as soon as the oil is clear, by stirring it well, by a little stronger heat, and as soon as the shellac will melt, put it in and cook to a soft pill, and reduce with the turpentine.

Spirit-copal is composed of 32 lbs. picked kauri gum; $1\frac{1}{2}$ pints bleached oil; 5 gals. turpentine; 2 gals. alcohol; and is made as follows: Melt the gum well and add the oil, the

kettle off the fire. Keep the lid on, and add carefully the turpentine. Then lid off and stir well from the bottom till all united. Then add slowly and stir in the alcohol. Can sell next day.

Method of producing different colors of No. 1 clear trunk-varnish for trunk work, etc. Mix and grind well in turpentine the colors you want, and mix them in some of the varnish to be colored, and mix them all in, say $\frac{1}{2}$ lb. color to each gallon of varnish. Use dry colors, such as Spanish brown, Venetian red, etc. For fine colors use better dry colors. For the common kinds, such as Spanish brown, etc., use say 1 lb. color to each gallon of varnish, but for stronger colors use say $\frac{1}{2}$ lb. to the gallon.

No. 1 or 2 Furniture, or Flowing Furniture, or Benzine Furniture.—A new process, costing 25 cents a gallon less than at present, and equally as good in all respects, is composed of 100 lbs. picked kauri-gum; 6 gals. furniture-oil; 30 to 32 gals. turpentine or benzine, as the case may be; and is made as follows: Proceed to melt the gum the usual way with a good fire all the way through till done. The first stage of the gum it is beginning to get soft; the second stage it is spongy and it will shove up the stirrer as you press it down into the gum; the third stage there comes a froth or suds, which you must whip down if it rises up much; the fourth stage is frothy drops; then comes soon after the fifth stage, or slow clear drops, at which time remove the kettle from the fire and add the oil as soon as you can and stir it well in—I mean add it as fast as it will go through the funnel. Then remove the lid from the kettle and whip down the froth, and cool and reduce in the usual way, but quite hot if you can. Put the lid on to cool off as soon as you whip down the head. The sixth stage, the appearance of the gum, and is what is called the quick, clear drop, is the time on all hard gum for the oil to be added. See thickness of furniture-oil for this gum. Add the oil to the gum at a gentle smoking heat. If it doesn't take all the reducing, the next time let the drops be a little slower, and *vice versa*. Can sell in the usual time, and it is brighter and harder. I don't say it will last quite as long bright on the work as the furniture-varnish previously described, but the difference

is so small that it is in favor of this process, as cheapness and a good fair article are all that the trade asks for. If you use benzine, use 60 gravity. For a flowing furniture, 7 or 8 gals. oil and some more reducing; you can use any amount of oil you want, but you will have to cook over the fire till done, as in wearing body, etc. Leave the varnish fully as stout as you do the other, previously described. The albumen on the gum is at the slow drop, fully developed at that time; but more cooking will destroy it so you can't get in nearly as much turpentine, etc. Hard gums do not possess this albumen so much, so you have to add the oil on them at the quick, clear drop.

Oiled-silk Varnish is made as follows: 100 lbs. Benguela or Zanzibar gum, as good a kind as you can get price for the varnish, and it should be the best, but no worse than the second kind; and say 8 or 9 gals. of No. 1 manganese-oil (or the No. 2 and thick-oil mixed), and cooked as in piano-polishing. If as much as 9 gals. oil, you may have to run it on the fire a minute or so after the oil is in, to get the long fine string on glass. When done cool as in piano polishing and reduce with say 22 gals. turpentine. This is used for a wash for the finishing coat on oiled silk. They reduce it with turpentine after they buy it. If it is too brittle on the silk add a little more oil, and *vice versa*. Can sell it as soon as done, but it is better a few days old.

Bleaching oils before and after they are cooked. Same process applies to oils before and after cooking: *viz.*, the agency of light alone. I would suggest that a room, similar to a hot-house for plants, with a southern exposure, be properly shelved, and the oil placed in large flat bottles, say each one holding 1 gal. Thirty days to the light will produce a most wonderful bleaching effect. A longer time would be better. The No. 2 manganese would then dry even better, and be quite light, a great desideratum. The thinner the light has to penetrate through the oil the better.

Furniture-oil, for oiling or staining furniture, is composed of 1 gal. bleached oil; 1 lb. alkanet root; $\frac{1}{2}$ lb. rose pink; 1 gal. liquid zinc drier, the kind with shellac in it; and is made as follows: Put the root in the oil and keep it over

the fire till it rises (look out or it will boil over); as soon as it rises some, remove it from the fire and continue this off and on, till the color is all out of the root, which will shortly take place—you can break some of the root and see if any color is left in it. Now add the liquid zinc drier to this root and oil, and have the oil so done warm while you add the pink ground fine and about the substance of molasses, and add it to the above. If the color is not strong enough, add more root and pink to suit. If it doesn't dry enough add more liquid zinc drier. Strain it while warm and let it settle till fine for sale; will fine down in a day or two. In cooking the root and oil, use kettle four times as large as the amount of oil taken, as it rises so much in the kettle. Dragon's-blood can be used in place of the alkanet root. Grind the pink in some of the same kind of oil.

Coach Painters' Japan.—Air-drying black for iron work on coaches, etc., is composed of 100 lbs. asphaltum; 15 gals. umber-oil No. 2; 3 lbs. red lead; 3 lbs. litharge; 25 lbs. hard gum; 3 lbs. best lampblack; and reduce with $\frac{4}{5}$ turpentine and $\frac{1}{5}$ benzine (60 gravity). Cook all through, as in the enamel top finish. If it doesn't dry quickly enough, leave out some of the oil and less driers, and reducing in proportion, and *vice versa*. If it is not bright enough, add more gum, and *vice versa*.

Air-drying Asphaltum.—A finer article (black) is composed of 120 lbs. asphaltum; 15 lbs. Burgundy pitch; 15 lbs. rosin; 3 to 4 lbs. best lampblack; 2 to 3 lbs. litharge; and reduce with $\frac{4}{5}$ turpentine and $\frac{1}{5}$ benzine. Melt the asphaltum well and cook 1 hour slowly, and to it add the rosin and pitch and get all well melted. Then add the litharge and cook 1 hour slowly and steadily. Then add the turpentine and then the benzine. Sift the lampblack in when you add the rosin and pitch.

Furniture Polish is composed of 1 oz. white angola gum (best); $\frac{1}{4}$ oz. best shellac; 1 pint alcohol; $1\frac{1}{4}$ oz. oil of cloves (some use oil of lavender); 2 qts. bleached oil. Dissolve the gum in the alcohol well, first pounding fine the gums or grinding them, and then add the oil of cloves and shake well up together for a few minutes. Then, as soon as it all goes well together, let it stand still say 5 minutes.

Then add the oil and shake well together. Let alcohol be the medium to make it thicker and thinner; but if it dries too slowly, then add less oil, and *vice versa*.

To Letter or Paint on Silk—a Sizing—is composed of 1 oz. gum-mastic; 1 oz. gum-sandarac; $\frac{1}{4}$ oz. Venice turpentine; 6 oz. spirit of turpentine. Pound the gum fine, and dissolve in warm turpentine, as in dammar varnish, adding the Venice turpentine at the time you do the gums. Can color afterward, with a mixture of gamboge and vermilion, or paris-green and turpentine. This applied to silk will prevent the letters, etc., from running and spreading.

Oak or Chestnut Stain is made as follows: Reduce the air-drying asphaltum with turpentine. Use less turpentine for the oak and more for the chestnut.

Inside Car-varnish is composed of 100 lbs. best Zanzibar gum; 13 gals. umber-oil No. 2; 2 gals. furniture-oil; 24 gals. (about) of camphine; and is made as follows: Observe the same rules as in wearing body; cook it so it strings a little more. If at any time any batch of varnish, japan, etc., doesn't take as much reducing as you wish, cook them more, and *vice versa*. If there is too much froth on batches when gum is in, the oil was too hot when put to the gum, and *vice versa*. The oil for this can be added to gum say at 340° , and do better.

N. B.—Always stop a little short and see the substance, and finish reducing as case requires. As you decrease the amount of oil, of course the batches will cool much quicker, and *vice versa*.

No. 1 Carriage for Finishing Coats is composed of 100 lbs. best Zanzibar gum; 12 gals. No. 1 manganese-oil, or the No. 2 and thick-oil mixed; 25 gals. (about) turpentine. Observe the same rules as in the last, only the cooking process will be shorter, and not so much oil is used. Add the oil at say 330° . Some use half best Zanzibar and half best Benguela, made separate and mixed warm afterward.

No. 1 Rubbing for All Work is composed of 100 lbs. picked kauri-gum; 9 gals. umber-oil No. 1; 25 gals. (about) turpentine—and another batch of 100 lbs. second kind Benguela gum; 9 gals. manganese-oil No. 2; 23 gals. (about) turpentine; and is made as follows: Add oil to gum at say

325°, or a gentle smoking heat (see remarks on cooking car inside); melt the gums separately and mix the varnishes separately afterward, when in a warm state, or make a batch of first one kind and then the other; so fill the can and draw and pour over when full. Can sell in 10 or 15 days.

Piano Scraping-varnish is composed of 90 lbs. second quality Zanzibar gum; 10 lbs. rosin; 4½ gals. furniture-oil; 22 gals. (about) turpentine; and is made as follows: Melt the rosin and gum together, and all other rules as in piano-polishing (formula following).

Ordinary Scraping for General Use is composed of ¾ No. 1 furniture-varnish of kauri-gum, and ¼ brown or shellac japan drier, mixed together warm after they are made.

Piano-Polishing is composed of 100 lbs. second quality Zanzibar gum; 6 gals. furniture-oil; 23 gals. (about) turpentine; and is made as follows: Add oil to gum when well melted, at say 320°. So little oil as this will be done enough, about as soon as the lid is removed from the gum-kettle. At any rate, if at any time you find a good froth on the batch, of 2 or 3 inches or even more, whip down the head occasionally till cool enough to reduce, which will be in say ½ to ¾ of an hour, or as soon as you see the turpentine goes in (small stream at first) without too much evaporation or causing the batch to foam or rise up rapidly. Stir the turpentine in well. You can tell if the batch is done, as it will string as in wearing body, on glass, etc.; if the string is fine and long as soon as put on glass, the batch is done; then cool and reduce. Can sell in 30 or 40 days; 2 months would be better. This string will work with all varnish, with about the same amount of oil in as above. As the amount of oil increases, the cooking must increase, as described in wearing body. If the varnish will dry quick enough to use all or part manganese-oil, it is better.

Light Elastic Baking Varnish, for finishing coats on light-colored-painted, or white-painted patent leather or enamelled cloth (sell at \$6 gal.), is composed of 100 lbs. best Zanzibar gum; 20 gals No. 1 manganese-oil, or the No. 2 manganese-oil and thick-oil mixed; 30 gals. (about) camphine; and is made as follows: Same rule for cooking as

for car inside, but cook so, when ready to cool off, it strings 3 to 6 ft. long. Can sell in 10 days. Store away in a warm place. If it does not bake fast enough, sell some fast vitreous with it (in damp weather this may be the case), and use four of this to one of vitreous, etc. An article can be made to sell for say \$4.50 to \$5, of a second-class Zanzibar gum, and all the rest of rules the same. Sell camphine, or have it used by those that reduce the two varnishes; and it should be reduced the day before it is used.

Dark Elastic Baking, for same purposes as previous varnish. Same all through as above, but use the P Benguela gum. This varnish and the foregoing won't take the amount of reducing, unless you cook it so that it makes the long fine strings spoken of.

Hard Drying Coach-Body Varnish is made as follows: Equal batch of medium-quality Zanzibar gum, or Benguela, with 12 gals. of No. 1 manganese-oil, or the No. 2 and thick-oil mixed, to each batch, made separate, etc.; and reduce each with say 24 gals. turpentine. Can sell in 30 days.

No. 1 Coach-Body Varnish.—It is sold mostly to druggists and dealers, but is not good enough for a customer. Is composed of 100 lbs. kauri-gum (as it comes, or picked if wanted lighter colored); 9 or 10 gals. umber-oil No. 1; 25 gals. (about) turpentine. Observe same rules as in piano-polishing; can sell soon as done.

Slow Vitreous Baking-varnish—for imitation marble on slate—is composed of 100 lbs. picked Zanzibar gum (pick out say half the case and get the lightest of it); 8 gals. magnesia-oil; about 21 gals. camphine. Same rules as in piano-polishing. The froth will be very light, as the oil is slow in drying. Can sell in 30 days. Store away in warm place. The kettle for these two varnishes should be very clean.

Fast Vitreous.—For polishing same as preceding work (marble). Observe same rules all the way through as in previous varnish, but use the No. 1 manganese-oil, or the No. 2 and thick-oil mixed, and cook as in piano-polishing. Parties using this and the last varnish mix them as they wish, some wanting a faster baking varnish, in which case add some fast vitreous, and *vice versa*. This varnish is

good for furniture, etc., light colors; but for a cheaper kind, such as is used on enameled furniture, etc., use say 6 gals. same oil and the gum is Kauri Saraped; use less oil if it dries too slowly and *vice versa*.

No. 1 Furniture (Turpentine) is composed of 100 lbs. picked kauri-gum; 6 gals. furniture-oil; about 23 gals. turpentine. Observe same rules as in piano-polishing. Can sell in about 4 days.

No. 2 Furniture (Turpentine).—Is the same as No. 1, but use a poorer gum.

No. 1 Flowing Furniture (Turpentine).—Sell the piano-polishing for this.

No. 2 Flowing Furniture is made as follows: Make two batches same way as the No. 2 furniture turpentine, but use 7 gals. instead of 6 gals. oil. Then make one batch of second-quality Benguela gum with 7 gals. same kind of oil, and mix the two together. Can sell in 30 days.

Benzine Furniture Nos. 1 and 2 is made as follows: Make as Nos. 1 and 2 furniture turpentine, same gum, oil, etc., but reduce with benzine, 62 and 68 gravity, half each. Add more carefully than you do turpentine, and be sure all fire is out around you; should do this always when you have benzine to use. Can sell as soon as done.

Brown Japan or Shellac Drier for Painters' Use is composed of 24 gals. umber-oil No. 2; 6 gals. bleached oil; 90 lbs. Campbell's or native shellac; 25 lbs. red lead; 25 lbs. litharge; 110 gals. turpentine or 120 gals. turpentine won't hurt it; and is made as follows: Heat oil to say 300° to 325°, and add the lead and litharge slowly, mixed together dry and sprinkled in the oil. In the mean time whip down the head, and when the lead and litharge are all in, and the head stands at say 3 or 4 inches thick, add the shellac slowly. The head will rise as you add it; but add it slowly, and keep the heat so that by whipping down the head moderately you can keep say 8 or 10 inches of froth on the batch. Once in a while stir the bottom and middle. Cook till by putting some on glass and cooling it in water you can get a soft, elastic pill, rolled up between your thumb and finger; then draw the kettle from the fire and cool down till a thin head on the batch, and then add the turpentine. It will

be cool enough to thin, say in $\frac{3}{4}$ of an hour, or as soon as you see the head break away some. If in cooking to these pills the batch doesn't take the amount of reducing, then cook stiffer pill, and *vice versa*.

Keep this kettle on the fire till done, if it doesn't get too hot; make certainly in a 120-gal. kettle, or 150-. Can sell in 3 or 4 days. After you get accustomed to the process you may keep the heat so that the head in the above kettle will come to within 10 inches of the top. In cooling off you can whip down the head often, until cool enough to reduce. The bleached oil makes it mix with raw oil better after it is done, in this as well as the next japan.

Gum Drying Japan.—For same use as last, but used a good deal by furniture men. Is composed of 100 lbs. P Benguela gum; 5 gals. bleached oil; 20 gals. umber-oil No. 2; 22 lbs. flake litharge; 22 lbs. red lead; 30 gals. turpentine; 60 gals. benzine (62 gravity), and if cooked just right it will carry 5 gals. more reducing. Is made as follows: Melt the gum well and add the oil at say 320° , the kettle now off the fire. As soon as the oil is in, take lid from gum-kettle and add slowly in same kettle the lead and litharge, with no froth as yet cooked on the batch, and then cook with 3 or 4 inches of froth on the batch for 3 or 4 hours, or till you get a soft elastic pill. Then cool off and add the turpentine first and then the benzine. Can sell in a few days. This can be made all through in gum-kettle. You can use even more benzine and less turpentine and have it mix with raw oil, or you can use say 6 gals. No. 1 coal-tar naphtha, added as soon as you get the turpentine in, and all the balance benzine, and have it mix with raw oil. If by using the 6 gals. of naphtha it doesn't mix, then use some more. The reducing with benzine and No. 1 coal-tar naphtha in place of turpentine (which is best) is only done to cheapen it; still it makes a very good article. The No. 1 coal-tar naphtha will make almost anything that doesn't mix right come out all right, by using some of it.

Parlor-varnish for wall-paper is composed of 100 lbs. picked Zanzibar gum (as in vitreous varnish); 5 gals. No. 1 manganese-oil, or the No. 2 and thick, mixed; 22 gals. (about) camphine. Cook as piano-polishing; but

so little oil as this will need no more cooking after the oil is in.

Picture-varnish.—Same as the parlor, but use the bleached oil. Can sell either one in 60 days, or perhaps in 30 if needed.

Furniture Japan for Filling Grain of Wood is composed of 100 lbs. P Benguela gum; 25 gals. umber-oil No. 2; 12 lbs. red lead; 13 lbs. litharge; 110 gals. benzine (62 gravity); and is made as follows: Melt the gum well, and add 18 gals. of the oil at say 330°; the other 7 gals. keep warm over another fire, and to it add the gum-and-oil batch, simply united (not cooked). Then add the lead and litharge slowly. Sprinkle them in, and cook as in the gum-japan drier and same kind of pill, only much harder, and cool and reduce in same way. This pill can be hard as the japan is only used for filling grain of wood. Can sell as quickly as made. A quicker kind is made with 15 gals. same oil and less driers and less reducing substance in proportion. Reduce like very thin furniture-varnish. Make in say 150-gal. kettle (iron).

N.B.—However, by using a portion of No. 1 coal-tar naphtha and less benzine this japan will mix with raw oil.

Enamel Top Finish for refinishing old carriage-tops. Is composed of 100 lbs. asphaltum; 30 gals. umber-oil No. 2; 12 lbs. red lead; 9 lbs. litharge; 66 lbs. dark Benguela or Zanzibar gum; 85 gals. turpentine; 10 gals. benzine (about) (62 gravity); 6 lbs. best lampblack; and is made as follows: Cook the asphaltum alone 1 hour at a good heat, and in the mean time add the lead and litharge to one-half the oil in another kettle, observing the same process the first hour as you do in making umber- or furniture-oil. Then add it slowly and stir it into the asphaltum kept hot. Then mix the lampblack in a paste with some of the oil previously taken out while only warm, and add it to the asphaltum and oil, and stir it well in slowly. Now keep this hot while you melt the gum and add it to the rest of the oil, in the usual way; oil say at 340°. As soon as in, take lid off this kettle and add this oil and gum to the other batch and cook so froth comes within 10 or 12 inches of the top of the 120-gal. kettle; whip down the head during cooking if necessary.

Cook for say 3 to 5 hours after gum-batch was put in, or till you get a moderately soft elastic pill by trying some in water on glass, and rolling it up between the fingers. Whip down the head till cool, and reduce in say $1\frac{1}{4}$ hours. Stir bottom once in a while. Can sell in 30 days. No straining into cans, and keep it in a warm place.

Directions for using it: Make a flour paste colored with some of the lampblack, and on any place where the leather is broken put on a thin coat of paste, but leave no paste on any other part of the leather. When paste is dry, apply thin coat of the finish—a thin coat in both substance and thickness.

Black Baking Japan (Ordinary).—For cheap work and a quick japan. Is composed of 100 lbs. asphaltum; 9 gals. furniture-oil; or 12 gals. oil and so on for a tougher article; and reduce with $\frac{2}{3}$ turpentine and $\frac{1}{3}$ benzine. Is made as follows: Melt the asphaltum well, and add the oil at say 350° , and stir it well in; then cook at a good heat to an elastic pill, as in rest of japans, and cool some to reduce. Mix this with the "Japan for Hardware Generally," to make a better article. Can sell in 10 days. As much as 18 gals. of oil can be used; of course it will then bake slower, but will be much tougher.

Black Baking Japan (Dense Colors).—One coat on coal scuttles, etc. Is composed of 200 lbs. asphaltum; 15 gals. umber-oil No. 2; 14 lbs. same umber as the other baking japans; 3 gals. hard-drying furniture-varnish. Cook the asphaltum 1 hour alone, and in mean time proceed with oil and umber as in the great-fender japan. Then unite the oil and umber to the asphaltum same way as in that japan, and cook to same pill; and add varnish first in reducing and then $\frac{2}{3}$ turpentine and $\frac{1}{3}$ benzine; all rest of rules the same; can sell in 30 days.

Brown Baking Japan, for tinware, is composed of 50 gals. bleached oil; 6 lbs. red lead; 17 lbs. roasted turkey umber, size of peas; 60 lbs. asphaltum; 40 gals. camphine; 13 gals. benzine 62 gravity; and is made as follows: Make half the above in a 120-gal. iron kettle and keep the head to within 12 to 14 inches of the top. Heat the oil in a separate kettle to say 325° , and to it add the lead the usual way,

and stir for $\frac{1}{2}$ hour or so more, or till the oil is clear; then add the umber loose (not in a basket). At this time have the asphaltum well melted in another kettle, and to it now add the oil so prepared, umber and all, and stir it slowly and well. Then cook as in the enamel top finish, and about as hot, for 12 to 18 hours, or till you can get a medium soft elastic pill, by cooling some in water, etc. Then cool and reduce. Can sell in 4 months; but they buy it ahead for use. Ten lbs. more asphaltum will give you a darker shade, and *vice versa*. Reduce with the camphine first, and then the benzine. Keep in a warm place to settle, no straining. Stir from the bottom often and carefully while cooking. The heat may go down at night and begin again the next day and so on until done.

Black Baking Japan for saddlery, hardware, sewing-machines, etc., where durability is wanted. Is composed of 40 gals. bleached oil; 15 lbs. best powdered China blue; 40 gals. camphine; 30 gals benzine (62 gravity); and is made as follows: Mix the blue well with some cold oil, say 5 gals., to a paste, and add it slowly to the balance of the oil in the iron kettle, and stir it well in. Then slowly get the heat up, so that by making one-half the above in a 120-gal. kettle, the head not to be kept higher than 12 to 15 inches of the top (or say at from 500° to 550°), or 4 inches of a head, a slow rolling, breaking one. Now so cook, stirring the bottom frequently and gently. If the head rises too much, whip it down, and keep cooking till you get a very soft pill by cooling some in water. Then cool, and when a thin head on add the camphine first and then the benzine. The substance when reduced is like stout furniture varnish. Can sell in 30 to 60 days. Cook more (the next time) if it doesn't take the reducing, and *vice versa*. The japan when done is brown, but will bake a beautiful black color, using two coats, as is required in all baking japans. By putting the blue in the oil over night and stirring it well, it is better. This japan can also be much improved by melting 15 to 20 lbs. of hard gum and adding to this gum, so melted, say 5 or 6 gals. bleached oil, and then adding it to the oil and blue kept warm; then cook to pill and reduce. Of course for this extra oil add more blue

and reduce in proportion. You can mix the hardware-generally japan with this as you wish, and to a certain extent it betters it, making it harder when dry.

Black Baking Japan for hardware generally, malleable iron castings, etc., is composed of 150 lbs. asphaltum; 50 lbs. Benguela or Zanzibar gum, a medium article; 25 gals. umber-oil No. 2; 20 lbs. roasted turkey umber, size of a pea; 38 gals. turpentine; 17 gals. benzine (62 gravity); 8 gals. saddlery hardware japan; and is made as follows: Heat about $\frac{2}{3}$ of the oil in a separate kettle to say 300° , and put the umber in it loose (not in a basket), and stir from the bottom occasionally. In the mean time cook the asphaltum alone for 1 hour, and then add the oil and umber, so kept hot, at say 350° . Now keep this cooking moderately while you melt the gum, and add to it the balance of the oil as in making varnishes. But as soon as oil is in the gum, take lid from gum-kettle and pour the oil and gum to the other batch of asphaltum, oil, and umber, and cook so the head comes within 12 or 15 inches of the top of the 120-gal. kettle, or 4 or 5 inches deep. Cook till as in enamel top finish, then cool as in that, and add the saddlery japan first, then the turpentine, and then the benzine. Sell for \$2 per gallon. Can sell in 30 days. Add all reducing as hot as as you can, stir all in well, and keep in a warm place to settle.

Black Baking Japan for Daguerreotype-plates is the same as the saddlery hardware japan, only use 22 lbs. of blue.

Black Baking Japan, imitation English for coach lamps, is composed of 100 lbs. asphaltum; 100 lbs. same gum as in previous japan; 19 gals. umber-oil No. 2; 14 lbs. same umber as in previous japan; 5 gals. saddlery japan; and is made as follows: Cook as in previous japan; reduce with $\frac{2}{3}$ turpentine and $\frac{1}{3}$ benzine. Can sell in 4 months. Sell for \$7 a gallon. Store away in warm place. But in this japan add fully $\frac{3}{4}$ of the oil to the gum (oil at say 300°); the balance as in hardware-generally japan. If it bakes too slowly add less oil and less saddlery japan. This rule of less oil applies to all japons, varnishes, etc.

Black Baking Japan for parlor grate-fenders, etc., is

composed of 140 lbs. asphaltum; 50 lbs. same gum as in previous japan; 14 lbs. same umber as in previous japan; 16 gals. umber-oil No. 2; 5 gals. saddlery japan. Observe all rules (but less reducing) as in last japan. And in this japan be sure to add half the oil to the gum (oil say at 325°). Reduce with $\frac{2}{3}$ turpentine and $\frac{1}{3}$ benzine.

No. 1 Black-trunk or Air-drying Asphaltum, for iron work of all kinds, is composed of 200 lbs. asphaltum; 26 gals. turpentine; 5 gals. coal-tar naphtha No. 1; 6 gals. furniture-oil; 18 lbs. rosin; 26 gals. benzine (62 gravity); and is made as follows: Cook the asphaltum alone for 1 hour, then add the oil, at say 325°, and cook 1 hour at good heat. Cool, and add the turpentine first, then the naphtha, and then the benzine. Put in the rosin when you do the asphaltum, and cook them up together. Can sell as soon as needed. Use more oil for a tougher article, and less for one quicker drying.

No. 2 Black-trunk Japan or Air-drying Asphaltum, for pasteboard on trunks. Is the same as No. 1, but use the No. 2 coal-tar naphtha in place of the turpentine. The No. 1 coal-tar naphtha is better, but higher priced. If the smell is too strong, use some benzine, or turpentine. Can sell as soon as made. One gallon of furniture-oil will toughen it.

No. 3 Air-drying Asphaltum (Cheap) for iron work, is made as follows: Melt coal-tar asphaltum (the pure), such as is used by roofers, and reduce with No. 2 coal-tar naphtha; or you can use the No. 1, which is sweeter, but costs more.

Plough, or Agricultural-implement Varnish, is composed of 100 lbs. picked kauri-gum; 10 gals. furniture-oil; about 22 gals. benzine (62 gravity). And cook as in the No. 1 furniture turpentine.

Turpentine varnish is made as follows: Melt one barrel of soft American turpentine and reduce it with 20 gals. of spirit of turpentine, and strain and put away for future use.

Liquid Zinc Drier is made as follows: No. 1 and No. 2 manganese-oil, 30 gals. when mixed, mixed so that you can keep the drier as light as you can, yet have it dry quick enough to suit you; and 2 lbs. white sugar of lead; and 2 shellac. Heat the oil say to 350°, and add the shellac, and

as soon as it is in add the lead slowly. Have it well dried and pounded fine before you add it. Add them with the kettle off the fire. Can sell next day. If you can afford to have it a darker shade, then add some more shellac and it will dry quicker. If the oil is not hot enough to act on the shellac, have it a little hotter. The more No. 2 manganese-oil you have, the quicker it will dry; of course it will be darker colored.

INDEX.

(See also pp. 322-329.)

- Acaroid resins, 27, 126
Acetone, 60
Air-blowing, 145, 158, 160
Alcohol, 57
 methyl or wood, 59
Amber, 25, 97
Analytical methods, 233; acetic acid, 255; celluloid, 316; linseed-oil, 308; oleoresinous varnish, 284; red lead, 268, 305; sp. gr. 235; volatile oils, 250
"Artificial skin" varnish, 36, 48
Asphaltum, 29, 72, 120

Balsams, 7
 copaiba, 7, 126
 turpentine, 8, 127
Beeswax, 33
Benzine, 53, 55, 72, 119
Benzoin, 23
Benzole (benzene), 56, 119, 246
Bisulphide of carbon, 60
Bone-black, 138

Camphor, 34, 126
Caoutchouc, 31, 121, 150
Carbon bisulphide, 60
 tetrachloride, 61, 135
Castor-oil, 48, 126
Catalysis, 63
Celluloid, 35, 133, 316
Ceresin, 33
China wood-oil (Tung-oil), 49, 315
Chinese lacquer, 2, 26
Chlorhydrin, 61, 133
Classifier (Thompson's) 200-214
Coal-tar pitch, 29
Collodion, 35
Colophony, 22, 158, 247

Colored resins, 27
Coloring-matters, 62, 137, 149
Condenser, 151, 156
Copal, 13, 96, 290-294
 cleaning of, 69
 -oil, 165
Corrosion of iron, 226-230
Crockett's varnish formulas, 333

Dammar, 15, 118, 134, 288-290, 302
Determination of proportion of pigments and oil, 188
Dichlorobenzol, 56
Dragon's-blood, 28
Driers, 63, 64, 79, 90, 251

Elemi, 21, 126
English varnish factory, 162
Ether, 59
Eugenic resin, 167

Fatty acids, 82, 94
Filtering, 81, 139
Filter press, 142
Flaxseed, 38
Fresson's compound, 149

Gamboge, 28
German varnish chimney, 112
 kettle, 111, 161
Glass-plate oil-tests, 46
Gutta-percha, 30, 122, 134

Hemp-seed-oil, 50

India rubber, 31, 121, 150
Japanese lacquer, 2, 26
Japan drier, 251

- Lac (shellac), 16, 17, 18, 246, 284, 285
- Lacquers, 4
Chinese or Japanese, 2, 26
- Lead acetate, 64, 80
linoleate, 64
oxide, 64, 79
red, 187, 305
resinate, 64, 67
sulphide, 67
white, 196-198, 222
- Lithopone, 262
- Manganese borate, 64, 80
linoleate, 64, 66
oxide, 64
resinate, 64, 67
sulphate, 65
- Manila copal, 173, 302
- Mastic, 19, 126
- Methyl (wood) alcohol, 59
- Monochlorobenzol, 56
- Nitrocellulose, 35, 133, 316
- Oil-varnish, 4, 78, 144
- Oleo-resinous varnish, 75, 89, 136, 151, 249, 284, 301
apparatus, 151
- Ozokerite, 33, 138
- Ozone, 41, 51,
- Paint, 179
cost of, 303
drying of, 192-195
durability of, 219, 224
for iron, 226
perishing of, 222
tests, 216, 225
- Paraffine, 34
- Parisian enamel, 37
- Picric acid, 138
- Pigments, 179
and oil, determination, 188
proportions, 180, 214
- Pigments, auxiliary, 215
finesness, 199
inert, 184, 186
opacity, 184
sp. gr., 180
table, 182
weight of 1 gal., 183
- Printers' ink, 145
- Prussian blue, in oil, 176
- Pyrocopal, 165
- Pyroxylin, 35, 133, 316
- Red Lead, action on oil, 187
composition, 187, 305
- Resenes, 12
- Resin, 8
cleaning, 69
dissolving, 10, 73
apparatus for, 75
esters, 35
hardness of, 9, 72, 161
melting, 73
apparatus for, 75
point, 9
mill for, 71
sifting, 73
synthetic, 166
of Baeyer, 169
Barth, 168
Blumer, 171
De Laire, 171
Hlasiwetz, *et al*, 166
Kleeburg, 170
Wurtz, 168
- Review of recent literature, 322
- Rosin, 22, 158, 247
-oil, 54
- Sandarac, 20, 126
- Scrim-oil, 158
- Shellac, 16, 246, 284, 285
bleaching, 17
wax, 18
- Soap lacquers, 148
- Solvents, 10

- Spermaceti, 34
- Spirit of turpentine, 51, 243, 299
 condenser, 151, 156
 odor, 52, 243
 oxidation of, 51
 polymerization of, 244
- Spirit varnish, 123
- Stand-oil, 158
- Steam jacket, 86, 120, 124
 superheater, 87, 109
- Synthetic resins, 166
- Terpineol, 61
- Thompson's classifier, 200-214
 paint test method, 216-219
- Tung (China wood) oil, 49, 315
- Varnish apparatus, 75, 83, 101,
 124, 139, 145, 153, 155-159,
 225, 227
 asphaltum, 120
 benzine, 119, 134
 bleaching, 138
 caoutchouc, 121
 casein, 150
 classification, 4, 126
 dammar, 15, 134
 darkening of, 67
 filtering, 139
 flatting, 33, 131, 302
 formulas, 97, 127, 132, 136, 153
- Varnish, history of, 3
 Japanese or Chinese, 2, 26
 making, 75, 90, 92, 151
 materials, 6, 96
 matt, 33, 131, 302
 patent-leather, 176
 qualities of, 1, 91, 96, 126
 resinates, 149
 storage, 90, 220, 223, 229
 spirit, 123, 148
 apparatus, 124, 139
 colored, 137
 formulas, 127, 132
 turpentine, 118
- Viscometer, 189
- Viscosity, 40, 189
- Walnut-oil, 50
- Walton's oil, 158
- Wax, 33
- White lead, 196-198
 Carter process, 198
 Dutch process, 197
 chalking of, 222
- White zinc, dissolving, 224
 peeling, 222
 viscosity of, 194
- Wood alcohol, 59
- Wood-oil (Chinese), 49, 315
- Zinc driers, 66, 80

SHORT-TITLE CATALOGUE

OF THE

PUBLICATIONS

OF

JOHN WILEY & SONS

NEW YORK

LONDON: CHAPMAN & HALL, LIMITED

ARRANGED UNDER SUBJECTS

Descriptive circulars sent on application. Books marked with an asterisk (*) are sold at *net* prices only. All books are bound in cloth unless otherwise stated.

AGRICULTURE—HORTICULTURE—FORESTRY.

Armsby's Principles of Animal Nutrition.....	8vo,	\$4 00
* Bowman's Forest Physiography.....	8vo,	5 00
Budd and Hansen's American Horticultural Manual:		
Part I. Propagation, Culture, and Improvement.....	12mo,	1 50
Part II. Systematic Pomology.....	12mo,	1 50
Elliott's Engineering for Land Drainage.....	12mo,	2 00
Practical Farm Drainage. (Second Edition, Rewritten.).....	12mo,	1 50
Fuller's Water Supplies for the Farm. (In Press.)		
Graves's Forest Mensuration.....	8vo,	4 00
* Principles of Handling Woodlands.....	Large 12mo,	1 50
Green's Principles of American Forestry.....	12mo,	1 50
Grottenfelt's Principles of Modern Dairy Practice. (Woll.).....	12mo,	2 00
Hawley and Hawes's Practical Forestry for New England. (In Press.)		
* Herrick's Denatured or Industrial Alcohol.....	8vo,	4 00
* Kemp and Waugh's Landscape Gardening. (New Edition, Rewritten.)	12mo,	1 50
* McKay and Larsen's Principles and Practice of Butter-making.....	8vo,	1 50
Maynard's Landscape Gardening as Applied to Home Decoration.....	12mo,	1 50
Record's Identification of the Economic Woods of the United States. (In Press.)		
Sanderson's Insects Injurious to Staple Crops.....	12mo,	1 50
* Insect Pests of Farm, Garden, and Orchard.....	Large 12mo,	3 00
* Schwarz's Longleaf Pine in Virgin Forest.....	12mo,	1 25
* Solotaroff's Field Book for Street-tree Mapping.....	12mo,	0 75
In lots of one dozen.....		8 00
* Shade Trees in Towns and Cities.....	8vo,	3 00
Stockbridge's Rocks and Soils.....	8vo,	2 50
Winton's Microscopy of Vegetable Foods.....	8vo,	7 50
Woll's Handbook for Farmers and Dairymen.....	16mo,	1 50

ARCHITECTURE.

* Atkinson's Orientation of Buildings or Planning for Sunlight.....	8vo,	2 00
Baldwin's Steam Heating for Buildings.....	12mo,	2 50
Berg's Buildings and Structures of American Railroads.....	4to,	5 00

Birkmire's Architectural Iron and Steel.....	8vo,	\$3 50
Compound Riveted Girders as Applied in Buildings.....	8vo,	2 00
Planning and Construction of High Office Buildings.....	8vo,	3 50
Skeleton Construction in Buildings.....	8vo,	3 00
Briggs's Modern American School Buildings.....	8vo,	4 00
Byrne's Inspection of Materials and Workmanship Employed in Construction.	16mo,	3 00
Carpenter's Heating and Ventilating of Buildings.....	8vo,	4 00
* Corthell's Allowable Pressure on Deep Foundations.....	12mo,	1 25
* Eckel's Building Stones and Clays.....	8vo,	3 00
Freitag's Architectural Engineering.....	8vo,	3 50
Fire Prevention and Fire Protection. (In Press.)		
Fireproofing of Steel Buildings.....	8vo,	2 50
Gerhard's Guide to Sanitary Inspections. (Fourth Edition, Entirely Re-		
vised and Enlarged.).....	12mo,	1 50
* Modern Baths and Bath Houses.....	8vo,	3 00
Sanitation of Public Buildings.....	12mo,	1 50
Theatre Fires and Panics.....	12mo,	1 50
* The Water Supply, Sewerage and Plumbing of Modern City Buildings,	8vo,	4 00
Johnson's Statics by Algebraic and Graphic Methods.....	8vo,	2 00
Kellaway's How to Lay Out Suburban Home Grounds.....	8vo,	2 00
Kidder's Architects' and Builders' Pocket-book.....	16mo, mor.,	5 00
Merrill's Stones for Building and Decoration.....	8vo,	5 00
Monckton's Stair-building.....	4to,	4 00
Patton's Practical Treatise on Foundations.....	8vo,	5 00
Peabody's Naval Architecture.....	8vc,	7 50
Rice's Concrete-block Manufacture.....	8vo,	2 00
Richey's Handbook for Superintendents of Construction.....	16mo, mor.	4 00
Building Foreman's Pocket Book and Ready Reference..	16mo, mor.	5 00
* Building Mechanics' Ready Reference Series:		
* Carpenters' and Woodworkers' Edition.....	16mo, mor.	1 50
* Cement Workers' and Plasterers' Edition.....	16mo, mor.	1 50
* Plumbers', Steam-Fitters', and Tinnners' Edition..	16mo, mor.	1 50
* Stone- and Brick-masons' Edition.....	16mo, mor.	1 50
Sabin's House Painting.....	12mo,	1 00
Siebert and Biggin's Modern Stone-cutting and Masonry.....	8vo,	1 50
Snow's Principal Species of Wood.....	8vo,	3 50
Wait's Engineering and Architectural Jurisprudence.....	8vo,	6 00
	Sheep,	6 50
Law of Contracts.....	8vo,	3 00
Law of Operations Preliminary to Construction in Engineering and		
Architecture.....	8vo,	5 00
	Sheep,	5 50
Wilson's Air Conditioning.....	12mo,	1 50
Worcester and Atkinson's Small Hospitals, Establishment and Maintenance,		
Suggestions for Hospital Architecture, with Plans for a Small		
Hospital.....	12mo,	1 25

ARMY AND NAVY.

Bernadou's Smokeless Powder, Nitro-cellulose, and the Theory of the Cellu-		
lose Molecule.....	12mo,	2 50
Chase's Art of Pattern Making.....	12mo,	2 50
Screw Propellers and Marine Propulsion.....	8vo,	3 00
* Cloke's Enlisted Specialists' Examiner.....	8vo,	2 00
* Gunner's Examiner.....	8vo,	1 50
Craig's Azimuth.....	4to,	3 50
Crehore and Squier's Polarizing Photo-chronograph.....	8vo,	3 00
* Davis's Elements of Law.....	8vo,	2 50
* Treatise on the Military Law of United States.....	8vo,	7 00
* Dudley's Military Law and the Procedure of Courts-martial..	Large	12mo,
		2 50
Durand's Resistance and Propulsion of Ships.....	8vo,	5 00
* Dyer's Handbook of Light Artillery.....	12mo,	3 00

Eissler's Modern High Explosives.....	8vo	\$4 00
* Fieberger's Text-book on Field Fortification.....	Large 12mo,	2 00
Hamilton and Bond's The Gunner's Catechism.....	18mo,	1 00
* Hoff's Elementary Naval Tactics.....	8vo,	1 50
Ingalls's Handbook of Problems in Direct Fire.....	8vo,	4 00
* Interior Ballistics.....	8vo,	3 00
* Lissak's Ordnance and Gunnery.....	8vo,	6 00
* Ludlow's Logarithmic and Trigonometric Tables.....	8vo,	1 00
* Lyons's Treatise on Electromagnetic Phenomena. Vols. I. and II.....	8vo, each,	6 00
* Mahan's Permanent Fortifications. (Mercur.).....	8vo, half mor,	7 50
Manual for Courts-martial.....	16mo, mor.	1 50
* Mercur's Attack of Fortified Places.....	12mo,	0 00
* Elements of the Art of War.....	8vo,	2 00
Nixon's Adjutants' Manual.....	24mo,	1 00
Peabody's Naval Architecture.....	8vo,	7 50
* Phelps's Practical Marine Surveying.....	8vo,	2 50
Putnam's Nautical Charts.....	8vo,	2 00
Rust's Ex-meridian Altitude, Azimuth and Star-Finding Tables.....	8vo,	5 00
* Selkirk's Catechism of Manual of Guard Duty.....	24mo,	0 50
Sharpe's Art of Subsisting Armies in War.....	18mo, mor.	1 50
* Taylor's Speed and Power of Ships. 2 vols. Text 8vo, plates oblong 4to,		7 50
* Tupes and Poole's Manual of Bayonet Exercises and Musketry Fencing.	24mo, leather,	0 50
	8vo,	3 00
* Weaver's Military Explosives.....	8vo,	3 00
* Woodhull's Military Hygiene for Officers of the Line.....	Large 12mo,	1 50

ASSAYING.

Betts's Lead Refining by Electrolysis.....	8vo,	4 00
* Butler's Handbook of Blowpipe Analysis.....	16mo,	0 75
Fletcher's Practical Instructions in Quantitative Assaying with the Blowpipe.	16mo, mor.	1 50
Furman and Pardoe's Manual of Practical Assaying.....	8vo,	3 00
Lodge's Notes on Assaying and Metallurgical Laboratory Experiments.....	8vo,	3 00
Low's Technical Methods of Ore Analysis.....	8vo,	3 00
Miller's Cyanide Process.....	12mo,	1 00
Manual of Assaying.....	12mo,	1 00
Minet's Production of Aluminum and its Industrial Use. (Waldo.).....	12mo,	2 50
Ricketts and Miller's Notes on Assaying.....	8vo,	3 00
Robine and Lenglen's Cyanide Industry. (Le Clerc.).....	8vo,	4 00
* Seamon's Manual for Assayers and Chemists.....	Large 12mo,	2 50
Ulke's Modern Electrolytic Copper Refining.....	8vo,	3 00
Wilson's Chlorination Process.....	12mo,	1 50
Cyanide Processes.....	12mo,	1 50

ASTRONOMY.

Comstock's Field Astronomy for Engineers.....	8vo,	2 50
Craig's Azimuth.....	4to,	3 50
Crandall's Text-book on Geodesy and Least Squares.....	8vo,	3 00
Doolittle's Treatise on Practical Astronomy.....	8vo,	4 00
Hayford's Text-book of Geodetic Astronomy.....	8vo,	3 00
Hosmer's Azimuth.....	16mo, mor.	1 00
* Text-book on Practical Astronomy.....	8vo,	2 00
Merriman's Elements of Precise Surveying and Geodesy.....	8vo,	2 50
* Michie and Harlow's Practical Astronomy.....	8vo,	3 00
Rust's Ex-meridian Altitude, Azimuth and Star-Finding Tables.....	8vo,	5 00
* White's Elements of Theoretical and Descriptive Astronomy.....	12mo,	2 00

CHEMISTRY.

* Abderhalden's Physiological Chemistry in Thirty Lectures. (Hall and Defren.).....	8vo,	5 00
* Abegg's Theory of Electrolytic Dissociation. (von Ende.).....	12mo,	1 25
Alexeyeff's General Principles of Organic Syntheses. (Matthews.).....	8vo,	3 00

Allen's Tables for Iron Analysis.....	8vo,	\$3 00
Armsby's Principles of Animal Nutrition.....	8vo,	4 00
Arnold's Compendium of Chemistry. (Mandel.).....	Large 12mo,	3 50
Association of State and National Food and Dairy Departments, Hartford Meeting, 1906.....	8vo,	3 00
Jamestown Meeting, 1907.....	8vo,	3 00
Austen's Notes for Chemical Students.....	12mo,	1 50
Bernadou's Smokeless Powder.—Nitro-cellulose, and Theory of the Cellulose Molecule.....	12mo,	2 50
* Biltz's Introduction to Inorganic Chemistry. (Hall and Phelan.).....	12mo,	1 25
Laboratory Methods of Inorganic Chemistry. (Hall and Blanchard.)	8vo,	3 00
* Bingham and White's Laboratory Manual of Inorganic Chemistry.....	12mo,	1 00
* Blanchard's Synthetic Inorganic Chemistry.....	12mo,	1 00
* Bottler's German and American Varnish Making. (Sabin.).....	Large 12mo,	3 50
Browne's Handbook of Sugar Analysis. (In Press.)		
* Browning's Introduction to the Rarer Elements.....	8vo,	1 50
* Butler's Handbook of Blowpipe Analysis.....	16mo,	0 75
* Claassen's Beet-sugar Manufacture. (Hall and Rolfe.).....	8vo,	3 00
Classen's Quantitative Chemical Analysis by Electrolysis. (Boltwood.).....	8vo,	3 00
Cohn's Indicators and Test-papers.....	12mo,	2 00
Tests and Reagents.....	8vo,	3 00
Cohnheim's Functions of Enzymes and Ferments. (In Press.)		
* Danneel's Electrochemistry. (Merriam.).....	12mo,	1 25
Dannerth's Methods of Textile Chemistry.....	12mo,	2 00
Duhem's Thermodynamics and Chemistry. (Burgess.).....	8vo,	4 00
Effront's Enzymes and their Applications. (Prescott.).....	8vo,	3 00
Eissler's Modern High Explosives.....	8vo,	4 00
* Fischer's Oedema.....	8vo,	2 00
* Physiology of Alimentation.....	Large 12mo,	2 00
Fletcher's Practical Instructions in Quantitative Assaying with the Blowpipe.	16mo, mor.	1 50
Fowler's Sewage Works Analyses.....	12mo,	2 00
Fresenius's Manual of Qualitative Chemical Analysis. (Wells.).....	8vo,	5 00
Manual of Qualitative Chemical Analysis. Part I. Descriptive. (Wells.).....	8vo,	3 00
Quantitative Chemical Analysis. (Cohn.) 2 vols.....	8vo,	12 50
When Sold Separately, Vol. I, \$6. Vol. II, \$8.		
Fuertes's Water and Public Health.....	12mo,	1 50
Turman and Pardoe's Manual of Practical Assaying.....	8vo,	3 00
* Getman's Exercises in Physical Chemistry.....	12mo,	2 00
Gill's Gas and Fuel Analysis for Engineers.....	12mo,	1 25
Gooch's Summary of Methods in Chemical Analysis. (In Press.)		
* Gooch and Browning's Outlines of Qualitative Chemical Analysis.	Large 12mo,	1 25
Grottenfelt's Principles of Modern Dairy Practice. (Woll.).....	12mo,	2 00
Groth's Introduction to Chemical Crystallography (Marshall).	12mo,	1 25
* Hammarsten's Text-book of Physiological Chemistry. (Mandel.).....	8vo,	4 00
Hanausek's Microscopy of Technical Products. (Winton.).....	8vo,	5 00
* Haskins and Macleod's Organic Chemistry.....	12mo,	2 00
* Herrick's Denatured or Industrial Alcohol.....	8vo,	4 00
Hinds's Inorganic Chemistry.....	8vo,	3 00
* Laboratory Manual for Students.....	12mo,	1 00
* Holleman's Laboratory Manual of Organic Chemistry for Beginners. (Walker.).....	12mo,	1 00
Text-book of Inorganic Chemistry. (Cooper.).....	8vo,	2 50
Text-book of Organic Chemistry. (Walker and Mott.).....	8vo,	2 50
Holley's Analysis of Paint and Varnish Products. (In Press.)		
* Lead and Zinc Pigments.....	Large 12mo,	3 00
Hopkins's Oil-chemists' Handbook.....	8vo,	3 00
Jackson's Directions for Laboratory Work in Physiological Chemistry.....	8vo,	1 25
Johnson's Rapid Methods for the Chemical Analysis of Special Steels, Steel-making Alloys and Graphite.....	Large 12mo,	3 00
Landauer's Spectrum Analysis. (Tingle.).....	8vo,	3 00
Lassar-Cohn's Application of Some General Reactions to Investigations in Organic Chemistry. (Tingle.).....	12mo,	1 00
Leach's Inspection and Analysis of Food with Special Reference to State Control.....	8vo,	7 50

Löb's Electrochemistry of Organic Compounds. (Lorenz.).....	8vo,	\$3 00
Lodge's Notes on Assaying and Metallurgical Laboratory Experiments..	8vo,	3 00
Low's Technical Method of Ore Analysis.....	8vo,	3 00
Lowe's Paint for Steel Structures.....	12mo,	1 00
Lunge's Techno-chemical Analysis. (Cohn.).....	12mo,	1 00
* McKay and Larsen's Principles and Practice of Butter-making.....	8vo,	1 50
Maire's Modern Pigments and their Vehicles.....	12mo,	2 00
Mandel's Handbook for Bio-chemical Laboratory.....	12mo,	1 50
* Martin's Laboratory Guide to Qualitative Analysis with the Blowpipe	12mo,	0 60
Mason's Examination of Water. (Chemical and Bacteriological.).....	12mo,	1 25
Water-supply. (Considered Principally from a Sanitary Standpoint.)	8vo,	4 00
* Mathewson's First Principles of Chemical Theory.....	8vo,	1 00
Mathewson's Laboratory Manual of Dyeing and Textile Chemistry.....	8vo,	3 50
Textile Fibres. 2d Edition, Rewritten.....	8vo,	4 00
* Meyer's Determination of Radicles in Carbon Compounds. (Tingle.)	12mo,	1 25
Third Edition.....	12mo,	1 25
Miller's Cyanide Process.....	12mo,	1 00
Manual of Assaying.....	12mo,	1 00
Minet's Production of Aluminum and its Industrial Use. (Waldo.).....	12mo,	2 50
* Mittelstaedt's Technical Calculations for Sugar Works. (Bourbakis.)	12mo,	1 50
Mixter's Elementary Text-book of Chemistry.....	12mo,	1 50
Morgan's Elements of Physical Chemistry.....	12mo,	3 00
* Physical Chemistry for Electrical Engineers.....	12mo,	1 50
* Moore's Experiments in Organic Chemistry.....	12mo,	0 50
* Outlines of Organic Chemistry.....	12mo,	1 50
Morse's Calculations used in Cane-sugar Factories.....	16mo, mor.	1 50
* Muir's History of Chemical Theories and Laws.....	8vo,	4 00
Mulliken's General Method for the Identification of Pure Organic Compounds.		
Vol. I. Compounds of Carbon with Hydrogen and Oxygen. Large	8vo,	5 00
Vol. II. Nitrogenous Compounds. (In Preparation.)		
Vol. III. The Commercial Dyestuffs.....	Large 8vo,	5 00
* Nelson's Analysis of Drugs and Medicines.....	12mo,	5 00
Ostwald's Conversations on Chemistry. Part One. (Ramsey.).....	12mo,	1 50
Part Two. (Turnbull.).....	12mo,	2 00
* Introduction to Chemistry. (Hall and Williams.).....	Large 12mo,	1 50
Owen and Standage's Dyeing and Cleaning of Textile Fabrics.....	12mo,	2 00
* Palmer's Practical Test Book of Chemistry.....	12mo,	1 00
* Pauli's Physical Chemistry in the Service of Medicine. (Fischer.)	12mo,	1 25
Penfield's Tables of Minerals, Including the Use of Minerals and Statistics		
of Domestic Production.....	8vo,	1 00
Pictet's Alkaloids and their Chemical Constitution. (Biddle.).....	8vo,	5 00
Poole's Calorific Power of Fuels.....	8vo,	3 00
Prescott and Winslow's Elements of Water Bacteriology, with Special Refer-		
ence to Sanitary Water Analysis.....	12mo,	1 50
* Reisig's Guide to Piece-Dyeing.....	8vo,	25 00
Richards and Woodman's Air, Water, and Food from a Sanitary Stand-		
point.....	8vo,	2 00
Ricketts and Miller's Notes on Assaying.....	8vo,	3 00
Rideal's Disinfection and the Preservation of Food.....	8vo,	4 00
Riggs's Elementary Manual for the Chemical Laboratory.....	8vo,	1 25
Robine and Lenglen's Cyanide Industry. (Le Clerc.).....	8vo,	4 00
Ruddiman's Incompatibilities in Prescriptions.....	8vo,	2 00
Whys in Pharmacy.....	12mo,	1 00
* Ruer's Elements of Metallography. (Mathewson.).....	8vo,	3 00
Sabin's Industrial and Artistic Technology of Paint and Varnish.....	8vo,	3 00
Salkowski's Physiological and Pathological Chemistry. (Orndorff.).....	8vo,	2 50
* Schimpf's Essentials of Volumetric Analysis.....	Large 12mo,	1 50
Manual of Volumetric Analysis. (Fifth Edition, Rewritten)....	8vo,	5 00
* Qualitative Chemical Analysis.....	8vo,	1 25
* Seamon's Manual for Assayers and Chemists.....	Large 12mo,	2 50
Smith's Lecture Notes on Chemistry for Dental Students.....	8vo,	2 50
Spencer's Handbook for Cane Sugar Manufacturers.....	16mo, mor.	3 00
Handbook for Chemists of Beet-sugar Houses.....	16mo, mor.	3 00
Stockbridge's Rocks and Soils.....	8vo,	2 50
Stone's Practical Testing of Gas and Gas Meters.....	8vo,	3 50

Ogden and Cleveland's Practical Methods of Sewage Disposal for Residences, Hotels, and Institutions. (In Press.)		
Parsons's Disposal of Municipal Refuse.....	8vo,	\$2 00
Patton's Treatise on Civil Engineering.....	8vo, half leather,	7 50
Reed's Topographical Drawing and Sketching.....	4to,	5 00
Riemer's Shaft-sinking under Difficult Conditions. (Corning and Peele.)	8vo,	3 00
Siebert and Biggin's Modern Stone-cutting and Masonry.....	8vo,	1 50
Smith's Manual of Topographical Drawing. (McMillan.)	8vo,	2 50
Soper's Air and Ventilation of Subways.....	12mo,	2 50
* Tracy's Exercises in Surveying.....	12mo, mor.	1 00
Tracy's Plane Surveying.....	16mo, mor.	3 00
Venable's Garbage Crematories in America.....	8vo,	2 00
Methods and Devices for Bacterial Treatment of Sewage.....	8vo,	3 00
Wait's Engineering and Architectural Jurisprudence.....	8vo,	6 00
	Sheep,	6 50
Law of Contracts.....	8vo,	3 00
Law of Operations Preliminary to Construction in Engineering and Architecture.....	8vo,	5 00
	Sheep,	5 50
Warren's Stereotomy—Problems in Stone-cutting.....	8vo,	2 50
* Waterbury's Vest-Pocket Hand-book of Mathematics for Engineers.	2 $\frac{7}{8}$ × 5 $\frac{3}{8}$ inches, mor.	1 00
* Enlarged Edition, Including Tables.....	mor.	1 50
Webb's Problems in the Use and Adjustment of Engineering Instruments.	16mo, mor.	1 25
Wilson's Topographic Surveying.....	8vo,	3 50

BRIDGES AND ROOFS.

Boller's Practical Treatise on the Construction of Iron Highway Bridges.	8vo,	2 00
* Thames River Bridge.....	Oblong paper,	5 00
Burr and Falk's Design and Construction of Metallic Bridges.....	8vo,	5 00
Influence Lines for Bridge and Roof Computations.....	8vo,	3 00
Du Bois's Mechanics of Engineering. Vol. II.....	Small 4to,	10 00
Foster's Treatise on Wooden Trestle Bridges.....	4to,	5 00
Fowler's Ordinary Foundations.....	8vo,	3 50
Greene's Arches in Wood, Iron, and Stone.....	8vo,	2 50
Bridge Trusses.....	8vo,	2 50
Roof Trusses.....	8vo,	1 25
Grimm's Secondary Stresses in Bridge Trusses.....	8vo,	2 50
Heller's Stresses in Structures and the Accompanying Deformations...	8vo,	3 00
Howe's Design of Simple Roof-trusses in Wood and Steel.....	8vo,	2 00
Symmetrical Masonry Arches.....	8vo,	2 50
Treatise on Arches.....	8vo,	4 00
* Hudson's Deflections and Statically Indeterminate Stresses....	Small 4to,	3 50
* Plate Girder Design.....	8vo,	1 50
* Jacoby's Structural Details, or Elements of Design in Heavy Framing,	8vo,	2 25
Johnson, Bryan and Turneure's Theory and Practice in the Designing of Modern Framed Structures.....	Small 4to,	10 00
* Johnson, Bryan and Turneure's Theory and Practice in the Designing of Modern Framed Structures. New Edition. Part I.....	8vo,	3 00
* Part II. New Edition.....	8vo,	4 00
Merriman and Jacoby's Text-book on Roofs and Bridges:		
Part I. Stresses in Simple Trusses.....	8vo,	2 50
Part II. Graphic Statics.....	8vo,	2 50
Part III. Bridge Design.....	8vo,	2 50
Part IV. Higher Structures.....	8vo,	2 50
Ricker's Design and Construction of Roofs. (In Press.)		
Sondericker's Graphic Statics, with Applications to Trusses, Beams, and Arches.....	8vo,	2 00
Waddell's De Pontibus, Pocket-book for Bridge Engineers.....	16mo, mor.	2 00
* Specifications for Steel Bridges.....	12mo,	50
Waddell and Harrington's Bridge Engineering. (In Preparation.)		

HYDRAULICS.

Barnes's Ice Formation.....	8vo,	3 00
Bazin's Experiments upon the Contraction of the Liquid Vein Issuing from an Orifice. (Trautwine.)	8vo,	2 00

Bovey's Treatise on Hydraulics.....	8vo,	\$5 00
Church's Diagrams of Mean Velocity of Water in Open Channels.	Oblong 4to, paper,	1 50
Hydraulic Motors.....	8vo,	2 00
Mechanics of Fluids (Being Part IV of Mechanics of Engineering).....	8vo,	3 00
Coffin's Graphical Solution of Hydraulic Problems.....	16mo, mor.	2 50
Flather's Dynamometers, and the Measurement of Power.....	12mo,	3 00
Folwell's Water-supply Engineering.....	8vo,	4 00
Frizell's Water-power.....	8vo,	5 00
Fuertes's Water and Public Health.....	12mo,	1 50
Water-filtration Works.....	12mo,	2 50
Ganguillet and Kutter's General Formula for the Uniform Flow of Water in Rivers and Other Channels. (Hering and Trautwine.).....	8vo,	4 00
Hazen's Clean Water and How to Get It.....	Large 12mo,	1 50
Filtration of Public Water-supplies.....	8vo,	3 00
Hazelhurst's Towers and Tanks for Water-works.....	8vo,	2 50
Herschel's 115 Experiments on the Carrying Capacity of Large, Riveted, Metal Conduits.....	8vo,	2 00
Hoyt and Grover's River Discharge.....	8vo,	2 00
Hubbard and Kiersted's Water-works, Management and Maintenance.	8vo,	4 00
* Lyndon's Development and Electrical Distribution of Water Power.	8vo,	3 00
Mason's Water-supply. (Considered Principally from a Sanitary Standpoint.).....	8vo,	4 00
* Merriman's Treatise on Hydraulics. 9th Edition, Rewritten.....	8vo,	4 00
* Molitor's Hydraulics of Rivers, Weirs and Sluices.....	8vo,	2 00
* Morrison and Brodie's High Masonry Dam Design.....	8vo,	1 50
* Richards's Laboratory Notes on Industrial Water Analysis.....	8vo,	50
Schuyler's Reservoirs for Irrigation, Water-power, and Domestic Water-supply. Second Edition, Revised and Enlarged.....	Large 8vo,	6 00
* Thomas and Watt's Improvement of Rivers.....	4to,	6 00
Turneure and Russell's Public Water-supplies.....	8vo,	5 00
* Wegmann's Design and Construction of Dams. 6th Ed., enlarged....	4to,	6 00
Water-Supply of the City of New York from 1658 to 1895.....	4to,	10 00
Whipple's Value of Pure Water.....	Large 12mo,	1 00
Williams and Hazen's Hydraulic Tables.....	8vo,	1 50
Wilson's Irrigation Engineering.....	8vo,	4 00
Wood's Turbines.....	8vo,	2 50

MATERIALS OF ENGINEERING.

Baker's Roads and Pavements.....	8vo,	5 00
Treatise on Masonry Construction.....	8vo,	5 00
Black's United States Public Works.....	Oblong 4to,	5 00
* Blanchard and Drowne's Highway Engineering, as Presented at the Second International Road Congress, Brussels, 1910.....	8vo,	2 00
Bleining's Manufacture of Hydraulic Cement. (In Preparation.)		
* Bottler's German and American Varnish Making. (Sabin.)..	Large 12mo.	3 50
Burr's Elasticity and Resistance of the Materials of Engineering.....	8vo,	7 50
Byrne's Highway Construction.....	8vo,	5 00
Inspection of the Materials and Workmanship Employed in Construction.	16mo,	3 00
Church's Mechanics of Engineering.....	8vo,	6 00
Mechanics of Solids (Being Parts I, II, III of Mechanics of Engineering).....	8vo,	4 50
Du Bois's Mechanics of Engineering.		
Vol. I. Kinematics, Statics, Kinetics.....	Small 4to,	7 50
Vol. II. The Stresses in Framed Structures, Strength of Materials and Theory of Flexures.....	Small 4to,	10 00
* Eckel's Building Stones and Clays.....	8vo.	3 00
* Cements, Limes, and Plasters.....	8vo,	6 00
Fowler's Ordinary Foundations.....	8vo,	3 50
* Greene's Structural Mechanics.....	8vo,	2 50
Holley's Analysis of Paint and Varnish Products. (In Press.)		
* Lead and Zinc Pigments.....	Large 12mo,	3 00

* Hubbard's Dust Preventives and Road Binders.....	8vo,	\$3 00
Johnson's (C. M.) Rapid Methods for the Chemical Analysis of Special Steels, Steel-making Alloys and Graphite.....	Large 12mo,	3 00
Johnson's (J. B.) Materials of Construction.....	Large 8vo,	6 00
Keep's Cast Iron.....	8vo,	2 50
Lanza's Applied Mechanics.....	8vo,	7 50
Lowe's Paints for Steel Structures.....	12mo,	1 00
Maire's Modern Pigments and their Vehicles.....	12mo,	2 00
* Martin's Text Book on Mechanics. Vol. I. Statics.....	12mo,	1 25
* Vol. II. Kinematics and Kinetics.....	12mo,	1 50
* Vol. III. Mechanics of Materials.....	12mo,	1 50
Maurer's Technical Mechanics.....	8vo,	4 00
Merrill's Stones for Building and Decoration.....	8vo,	5 00
Merriman's Mechanics of Materials.....	8vo,	5 00
* Strength of Materials.....	12mo,	1 00
Metcalfe's Steel. A Manual for Steel-users.....	12mo,	2 00
Morrison's Highway Engineering.....	8vo,	2 50
* Murdock's Strength of Materials.....	12mo,	2 00
Patton's Practical Treatise on Foundations.....	8vo,	5 00
Rice's Concrete Block Manufacture.....	8vo,	2 00
Richardson's Modern Asphalt Pavement.....	8vo,	3 00
Richey's Building Foreman's Pocket Book and Ready Reference.....	16mo, mor.	5 00
* Cement Workers' and Plasterers' Edition (Building Mechanics' Ready Reference Series).....	16mo, mor.	1 50
Handbook for Superintendents of Construction.....	16mo, mor.	4 00
* Stone and Brick Masons' Edition (Building Mechanics' Ready Reference Series).....	16mo, mor.	1 50
* Ries's Clays: Their Occurrence, Properties, and Uses.....	8vo,	5 00
* Ries and Leighton's History of the Clay-working Industry of the United States.....	8vo,	2 50
Sabin's Industrial and Artistic Technology of Paint and Varnish.....	8vo,	3 00
* Smith's Strength of Material.....	12mo,	1 25
Snow's Principal Species of Wood.....	8vo,	3 50
Spalding's Hydraulic Cement.....	12mo,	2 00
Text-book on Roads and Pavements.....	12mo,	2 00
* Taylor and Thompson's Concrete Costs.....	Small 8vo,	5 00
* Extracts on Reinforced Concrete Design.....	8vo,	2 00
Treatise on Concrete, Plain and Reinforced.....	8vo,	5 00
Thurston's Materials of Engineering. In Three Parts.....	8vo,	8 00
Part I. Non-metallic Materials of Engineering and Metallurgy....	8vo,	2 00
Part II. Iron and Steel.....	8vo,	3 50
Part III. A Treatise on Brasses, Bronzes, and Other Alloys and their Constituents.....	8vo,	2 50
Tillson's Street Pavements and Paving Materials.....	8vo,	4 00
Turneure and Maurer's Principles of Reinforced Concrete Construction. Second Edition, Revised and Enlarged.....	8vo,	3 50
Waterbury's Cement Laboratory Manual.....	12mo,	1 00
* Laboratory Manual for Testing Materials of Construction.....	12mo,	1 50
Wood's (De V.) Treatise on the Resistance of Materials, and an Appendix on the Preservation of Timber.....	8vo,	2 00
Wood's (M. P.) Rustless Coatings: Corrosion and Electrolysis of Iron and Steel.....	8vo,	4 00

RAILWAY ENGINEERING.

Andrews's Handbook for Street Railway Engineers.....	3×5 inches, mor.	1 25
Berg's Buildings and Structures of American Railroads.....	4to,	5 00
Brooks's Handbook of Street Railroad Location.....	16mo, mor.	1 50
* Burt's Railway Station Service.....	12mo,	2 00
Butts's Civil Engineer's Field-book.....	16mo, mor.	2 50
Crandall's Railway and Other Earthwork Tables.....	8vo,	1 50
Crandall and Barnes's Railroad Surveying	16mo, mor.	2 00
* Crockett's Methods for Earthwork Computations.....	8vo,	1 50
Dredge's History of the Pennsylvania Railroad. (1879).....	Paper,	5 00
Fisher's Table of Cubic Yards.....	Cardboard,	25
Godwin's. Railroad Engineers' Field-book and Explorers' Guide..	16mo, mor.	2 50

Hudson's Tables for Calculating the Cubic Contents of Excavations and Embankments.....	8vo,	\$1 00
Ives and Hilts's Problems in Surveying, Railroad Surveying and Geodesy	16mo, mor.	1 50
Molitor and Beard's Manual for Resident Engineers.....	16mo,	1 00
Nagle's Field Manual for Railroad Engineers.....	16mo, mor.	3 00
* Orrock's Railroad Structures and Estimates.....	8vo,	3 00
Philbrick's Field Manual for Engineers.....	16mo, mor.	3 00
Raymond's Railroad Field Geometry.....	16mo, mor.	2 00
Elements of Railroad Engineering.....	8vo,	3 50
Railroad Engineer's Field Book. (In Preparation.)		
Roberts' Track Formulæ and Tables.....	16mo, mor.	3 00
Searles's Field Engineering.....	16mo, mor.	3 00
Railroad Spiral.....	16mo, mor.	1 50
Taylor's Prismatical Formulæ and Earthwork.....	8vo,	1 50
Webb's Economics of Railroad Construction.....	Large 12mo,	2 50
Railroad Construction.....	16mo, mor.	5 00
Wellington's Economic Theory of the Location of Railways.....	Large 12mo,	5 00
Wilson's Elements of Railroad-Track and Construction.....	12mo,	2 00

DRAWING

Barr and Wood's Kinematics of Machinery.....	8vo,	2 50
* Bartlett's Mechanical Drawing.....	8vo,	3 00
* " " " " Abridged Ed.....	8vo,	1 50
* Bartlett and Johnson's Engineering Descriptive Geometry.....	8vo,	1 50
Blessing and Darling's Descriptive Geometry. (In Press.)		
Elements of Drawing. (In Press.)		
Coolidge's Manual of Drawing.....	8vo, paper,	1 00
Coolidge and Freeman's Elements of General Drafting for Mechanical Engineers.....	Oblong 4to,	2 50
Durley's Kinematics of Machines.....	8vo,	4 00
Emch's Introduction to Projective Geometry and its Application.....	8vo,	2 50
Hill's Text-book on Shades and Shadows, and Perspective.....	8vo,	2 00
Jamison's Advanced Mechanical Drawing.....	8vo,	2 00
Elements of Mechanical Drawing.....	8vo,	2 50
Jones's Machine Design:		
Part I. Kinematics of Machinery.....	8vo,	1 50
Part II. Form, Strength, and Proportions of Parts.....	8vo,	3 00
* Kimball and Barr's Machine Design.....	8vo,	3 00
MacCord's Elements of Descriptive Geometry.....	8vo,	3 00
Kinematics; or, Practical Mechanism.....	8vo,	5 00
Mechanical Drawing.....	4to,	4 00
Velocity Diagrams.....	8vo,	1 50
McLeod's Descriptive Geometry.....	Large 12mo,	1 50
* Mahan's Descriptive Geometry and Stone-cutting.....	8vo,	1 50
Industrial Drawing. (Thompson.).....	8vo,	3 50
Moyer's Descriptive Geometry.....	8vo,	2 00
Reed's Topographical Drawing and Sketching.....	4to,	5 00
* Reid's Mechanical Drawing. (Elementary and Advanced.).....	8vo,	2 00
Text-book of Mechanical Drawing and Elementary Machine Design.....	8vo,	3 00
Robinson's Principles of Mechanism.....	8vo,	3 00
Schwamb and Merrill's Elements of Mechanism.....	8vo,	3 00
Smith (A. W.) and Marx's Machine Design.....	8vo,	3 00
Smith's (R. S.) Manual of Topographical Drawing. (McMillan.).....	8vo,	2 50
* Titsworth's Elements of Mechanical Drawing.....	Oblong 8vo,	1 25
Tracy and North's Descriptive Geometry. (In Press.)		
Warren's Elements of Descriptive Geometry, Shadows, and Perspective.....	8vo,	3 50
Elements of Machine Construction and Drawing.....	8vo,	7 50
Elements of Plane and Solid Free-hand Geometrical Drawing.....	12mo,	1 00
General Problems of Shades and Shadows.....	8vo,	3 00
Manual of Elementary Problems in the Linear Perspective of Forms and Shadow.....	12mo,	1 00
Manual of Elementary Projection Drawing.....	12mo,	1 50
Plane Problems in Elementary Geometry.....	12mo,	1 25
Weisbach's Kinematics and Power of Transmission. (Hermann and Klein.).....	8vo,	5 00

Wilson's (H. M.) Topographic Surveying.....	8vo,	\$3 50
* Wilson's (V. T.) Descriptive Geometry.....	8vo,	1 50
Free-hand Lettering.....	8vo,	1 00
Free-hand Perspective.....	8vo,	2 50
Woolf's Elementary Course in Descriptive Geometry.....	Large 8vo,	3 00

ELECTRICITY AND PHYSICS.

* Abegg's Theory of Electrolytic Dissociation. (von Ende.).....	12mo,	1 25
Andrews's Hand-book for Street Railway Engineers.....	3×5 inches	1 25
Anthony and Ball's Lecture-notes on the Theory of Electrical Measurements.....	12mo,	1 00
Anthony and Brackett's Text-book of Physics. (Magie.)....	Large 12mo,	3 00
Benjamin's History of Electricity.....	8vo,	3 00
Betts's Lead Refining and Electrolysis.....	8vo,	4 00
* Burgess and Le Chatelier's Measurement of High Temperatures. Third Edition.....	8vo,	4 00
Classen's Quantitative Chemical Analysis by Electrolysis. (Boltwood.)	8vo,	3 00
* Collins's Manual of Wireless Telegraphy and Telephony.....	12mo,	1 50
Crehone and Squier's Polarizing Photo-chronograph.....	8vo,	3 00
* Danneel's Electrochemistry. (Merriam.).....	12mo,	1 25
Dawson's "Engineering" and Electric Traction Pocket-book....	16mo, mor.	5 00
Dolezalek's Theory of the Lead Accumulator (Storage Battery). (von Ende.)	12mo,	2 50
Duhem's Thermodynamics and Chemistry. (Burgess.).....	8vo,	4 00
Flather's Dynamometers, and the Measurement of Power.....	12mo,	3 00
* Getman's Introduction to Physical Science.	12mo,	1 50
Gilbert's De Magnete. (Mottelay).....	8vo,	2 50
* Hanchett's Alternating Currents.....	12mo,	1 00
Hering's Ready Reference Tables (Conversion Factors).....	16mo, mor.	2 50
* Hobart and Ellis's High-speed Dynamo Electric Machinery.....	8vo,	6 00
Holman's Precision of Measurements.....	8vo,	2 00
Telescope-Mirror-scale Method, Adjustments, and Tests....	Large 8vo,	0 75
* Hutchinson's High-Efficiency Electrical Illuminants and Illumination.	Large 12mo,	2 50
* Jones's Electric Ignition.....	8vo,	4 00
Karapetoff's Experimental Electrical Engineering:		
* Vol. I.....	8vo,	3 50
* Vol. II.....	8vo,	2 50
Kinzbrunner's Testing of Continuous-current Machines.....	8vo,	2 00
Landauer's Spectrum Analysis. (Tingle.).....	8vo,	3 00
Löb's Electrochemistry of Organic Compounds. (Lorenz.).....	8vo,	3 00
* Lyndon's Development and Electrical Distribution of Water Power. 8vo,	3 00	
* Lyons's Treatise on Electromagnetic Phenomena. Vols. I. and II. 8vo, each,	6 00	
* Michie's Elements of Wave Motion Relating to Sound and Light....	8vo,	4 00
* Morgan's Physical Chemistry for Electrical Engineers.	12mo,	1 50
* Norris's Introduction to the Study of Electrical Engineering.....	8vo,	2 50
Norris and Dennison's Course of Problems on the Electrical Characteristics of Circuits and Machines. (In Press.)		
* Parshall and Hobart's Electric Machine Design.....	4to, half mor.	12 50
Reagan's Locomotives: Simple, Compound, and Electric. New Edition.		
Large 12mo,	3 50	
* Rosenberg's Electrical Engineering. (Haldane Gee—Kinzbrunner.)..	8vo,	2 00
* Ryan's Design of Electrical Machinery:		
* Vol. I. Direct Current Dynamos.....	8vo,	1 50
Vol. II. Alternating Current Transformers. (In Press.)		
Vol. III. Alternators, Synchronous Motors, and Rotary Convertors. (In Preparation.)		
Ryan, Norris, and Hoxie's Text Book of Electrical Machinery.....	8vo,	2 50
Schapper's Laboratory Guide for Students in Physical Chemistry....	12mo,	1 00
* Tillman's Elementary Lessons in Heat.....	8vo,	1 50
* Timbie's Elements of Electricity.....	Large 12mo,	2 00
* Answers to Problems in Elements of Electricity.....	12mo, Paper	0 25
Tory and Pitcher's Manual of Laboratory Physics.....	Large 12mo,	2 00
Ulke's Modern Electrolytic Copper Refining.....	8vo,	3 00
* Waters's Commercial Dynamo Design.....	8vo,	2 00

LAW.

* Brennan's Hand-book of Useful Legal Information for Business Men.	16mo, mor.	\$5 00
* Davis's Elements of Law.....	8vo,	2 50
* Treatise on the Military Law of United States.....	8vo,	7 00
* Dudley's Military Law and the Procedure of Courts-martial..	Large 12mo,	2 50
Manual for Courts-martial.....	16mo, mor.	1 50
Wait's Engineering and Architectural Jurisprudence.....	8vo,	6 00
	Sheep,	6 50
Law of Contracts.....	8vo,	3 00
Law of Operations Preliminary to Construction in Engineering and Architecture.....	8vo,	5 00
	Sheep,	5 50

MATHEMATICS.

Baker's Elliptic Functions.....	8vo,	1 50
Briggs's Elements of Plane Analytic Geometry. (Bôcher.)	12mo,	1 00
* Buchanan's Plane and Spherical Trigonometry.....	8vo,	1 00
Byerly's Harmonic Functions.....	8vo,	1 00
Chandler's Elements of the Infinitesimal Calculus.....	12mo,	2 00
* Coffin's Vector Analysis.	12mo,	2 50
Compton's Manual of Logarithmic Computations.....	12mo,	1 50
* Dickson's College Algebra.....	Large 12mo,	1 50
* Introduction to the Theory of Algebraic Equations.....	Large 12mo,	1 25
Emch's Introduction to Projective Geometry and its Application....	8vo,	2 50
Fiske's Functions of a Complex Variable.....	8vo,	1 00
Halsted's Elementary Synthetic Geometry.....	8vo,	1 50
Elements of Geometry.....	8vo,	1 75
* Rational Geometry.....	12mo,	1 50
Synthetic Projective Geometry.....	8vo,	1 00
* Hancock's Lectures on the Theory of Elliptic Functions.....	8vo,	5 00
Hyde's Grassmann's Space Analysis.....	8vo,	1 00
* Johnson's (J. B.) Three-place Logarithmic Tables: Vest-pocket size, paper,	* 100 copies,	5 00
	* Mounted on heavy cardboard, 8×10 inches,	0 25
	* 10 copies,	2 00
Johnson's (W. W.) Abridged Editions of Differential and Integral Calculus.	Large 12mo, 1 vol.	2 50
Curve Tracing in Cartesian Co-ordinates.....	12mo,	1 00
Differential Equations.....	8vo,	1 00
Elementary Treatise on Differential Calculus.....	Large 12mo,	1 50
Elementary Treatise on the Integral Calculus.....	Large 12mo,	1 50
* Theoretical Mechanics.....	12mo,	3 00
Theory of Errors and the Method of Least Squares.....	12mo,	1 50
Treatise on Differential Calculus.....	Large 12mo,	3 00
Treatise on the Integral Calculus.....	Large 12mo,	3 00
Treatise on Ordinary and Partial Differential Equations... Large	12mo,	3 50
Karapetoff's Engineering Applications of Higher Mathematics:		
* Part I. Problems on Machine Design.....	Large 12mo,	0 75
Koch's Practical Mathematics. (In Press.)		
Laplace's Philosophical Essay on Probabilities. (Truscott and Emory.)	12mo,	2 00
* Le Messurier's Key to Professor W. W. Johnson's Differential Equations.	Small 8vo,	1 75
* Ludlow's Logarithmic and Trigonometric Tables.....	8vo,	1 00
* Ludlow and Bass's Elements of Trigonometry and Logarithmic and Other Tables.....	8vo,	3 00
* Trigonometry and Tables published separately.....	Each,	2 00
Macfarlane's Vector Analysis and Quaternions.....	8vo,	1 00
McMahon's Hyperbolic Functions.....	8vo,	1 00
Manning's Irrational Numbers and their Representation by Sequences and Series.....	12mo,	1 25
* Martin's Text Book on Mechanics. Vol. I. Statics.....	12mo,	1 25
* Vol. II. Kinematics and Kinetics.....	12mo,	1 50
* Vol. III. Mechanics of Materials.....	12mo,	1 50

Mathematical Monographs. Edited by Mansfield Merriman and Robert S. Woodward.....	Octavo, each	\$1 00
No. 1. History of Modern Mathematics, by David Eugene Smith.		
No. 2. Synthetic Projective Geometry, by George Bruce Halsted		
No. 3. Determinants, by Laenas Gifford Weld. No. 4. Hyperbolic Functions, by James McMahon. No. 5. Harmonic Functions, by William E. Byerly. No. 6. Grassmann's Space Analysis, by Edward W. Hyde. No. 7. Probability and Theory of Errors, by Robert S. Woodward. No. 8. Vector Analysis and Quaternions, by Alexander Macfarlane. No. 9. Differential Equations, by William Woolsey Johnson. No. 10. The Solution of Equations, by Mansfield Merriman. No. 11. Functions of a Complex Variable, by Thomas S. Fiske.		
Maurer's Technical Mechanics.....	8vo,	4 00
Merriman's Method of Least Squares.....	8vo,	2 00
Solution of Equations.....	8vo,	1 00
* Moritz's Elements of Plane Trigonometry.....	8vo,	2 00
Rice and Johnson's Differential and Integral Calculus. 2 vols. in one.		
	Large 12mo,	1 50
Elementary Treatise on the Differential Calculus.....	Large 12mo,	3 00
Smith's History of Modern Mathematics.....	8vo,	1 00
* Veblen and Lennes's Introduction to the Real Infinitesimal Analysis of One Variable.....	8vo,	2 00
* Waterbury's Vest Pocket Hand-book of Mathematics for Engineers.		
	2 $\frac{1}{2}$ × 5 $\frac{1}{2}$ inches, mor.	1 00
* Enlarged Edition, Including Tables.....	mor.	1 50
Weld's Determinants.....	8vo,	1 00
Wood's Elements of Co-ordinate Geometry.....	8vo,	2 00
Woodward's Probability and Theory of Errors.....	8vo,	1 00

MECHANICAL ENGINEERING.

MATERIALS OF ENGINEERING, STEAM-ENGINES AND BOILERS.

Bacon's Forge Practice.....	12mo,	1 50
Baldwin's Steam Heating for Buildings.....	12mo,	2 50
Barr and Wood's Kinematics of Machinery.....	8vo,	2 50
* Bartlett's Mechanical Drawing.....	8vo,	3 00
* " " " " Abridged Ed.....	8vo,	1 50
* Bartlett and Johnson's Engineering Descriptive Geometry.....	8vo,	1 50
* Burr's Ancient and Modern Engineering and the Isthmian Canal.....	8vo,	3 50
Carpenter's Heating and Ventilating Buildings.....	8vo,	4 00
* Carpenter and Diederichs's Experimental Engineering.....	8vo,	6 00
* Clerk's The Gas, Petrol and Oil Engine.....	8vo,	4 00
Compton's First Lessons in Metal Working.....	12mo,	1 50
Compton and De Groodt's Speed Lathe.....	12mo,	1 50
Coolidge's Manual of Drawing.....	8vo, paper,	1 00
Coolidge and Freeman's Elements of General Drafting for Mechanical Engineers.....	Oblong 4to,	2 50
Cromwell's Treatise on Belts and Pulleys.....	12mo,	1 50
Treatise on Toothed Gearing.....	12mo,	1 50
Dingey's Machinery Pattern Making.....	12mo,	2 00
Durley's Kinematics of Machines.....	8vo,	4 00
Flanders's Gear-cutting Machinery.....	Large 12mo,	3 00
Flather's Dynamometers and the Measurement of Power.....	12mo,	3 00
Rope Driving.....	12mo,	2 00
Gill's Gas and Fuel Analysis for Engineers.....	12mo,	1 25
Goss's Locomotive Sparks.....	8vo,	2 00
* Greene's Pumping Machinery.....	8vo,	4 00
Hering's Ready Reference Tables (Conversion Factors).....	16mo, mor.	2 50
* Hobart and Ellis's High Speed Dynamo Electric Machinery.....	8vo,	6 00
Hutton's Gas Engine.....	8vo,	5 00
Jamison's Advanced Mechanical Drawing.....	8vo,	2 00
Elements of Mechanical Drawing.....	8vo,	2 50
Jones's Gas Engine.....	8vo,	4 00
Machine Design:		
Part I. Kinematics of Machinery.....	8vo,	1 50
Part II. Form, Strength, and Proportions of Parts.....	8vo,	3 00

* Kaup's Machine Shop Practice.	Large 12mo	\$1 25
* Kent's Mechanical Engineer's Pocket-Book	16mo, mor.	5 00
Kerr's Power and Power Transmission.	8vo,	2 00
* Kimball and Barr's Machine Design.	8vo,	3 00
* King's Elements of the Mechanics of Materials and of Power of Transmission.	8vo,	2 50
* Lanza's Dynamics of Machinery.	8vo,	2 50
Leonard's Machine Shop Tools and Methods.	8vo,	4 00
* Levin's Gas Engine.	8vo,	4 00
* Lorenz's Modern Refrigerating Machinery. (Pope, Haven, and Dean).	8vo,	4 00
MacCord's Kinematics; or; Practical Mechanism.	8vo,	5 00
Mechanical Drawing.	4to,	4 00
Velocity Diagrams.	8vo,	1 50
MacFarland's Standard Reduction Factors for Gases.	8vo,	1 50
Mahan's Industrial Drawing. (Thompson).	8vo,	3 50
Mehrtens's Gas Engine Theory and Design.	Large 12mo,	2 50
Miller, Berry, and Riley's Problems in Thermodynamics and Heat Engineering.	8vo, paper,	0 75
Oberg's Handbook of Small Tools.	Large 12mo,	2 50
* Parshall and Hobart's Electric Machine Design. Small 4to, half leather,		12 50
* Peele's Compressed Air Plant. Second Edition, Revised and Enlarged.	8vo,	3 50
* Perkins's Introduction to General Thermodynamics	12mo,	1 50
Poole's Calorific Power of Fuels.	8vo,	3 00
* Porter's Engineering Reminiscences, 1855 to 1882.	8vo,	3 00
Randall's Treatise on Heat. (In Press.)		
* Reid's Mechanical Drawing. (Elementary and Advanced.)	8vo,	2 00
Text-book of Mechanical Drawing and Elementary Machine Design.	8vo,	3 00
Richards's Compressed Air.	12mo,	1 50
Robinson's Principles of Mechanism.	8vo,	3 00
Schwamb and Merrill's Elements of Mechanism.	8vo,	3 00
Smith (A. W.) and Marx's Machine Design.	8vo,	3 00
Smith's (O.) Press-working of Metals.	8vo,	3 00
Sorel's Carbureting and Combustion in Alcohol Engines. (Woodward and Preston).	Large 12mo,	3 00
Stone's Practical Testing of Gas and Gas Meters.	8vo,	3 50
Thurston's Animal as a Machine and Prime Motor, and the Laws of Energetics.	12mo,	1 00
Treatise on Friction and Lost Work in Machinery and Mill Work.	8vo,	3 00
* Tillson's Complete Automobile Instructor.	16mo,	1 50
* Titsworth's Elements of Mechanical Drawing.	Oblong 8vo,	1 25
Warren's Elements of Machine Construction and Drawing.	8vo,	7 50
* Waterbury's Vest Pocket Hand-book of Mathematics for Engineers.	2 $\frac{1}{4}$ × 5 $\frac{3}{8}$ inches, mor.	1 00
* Enlarged Edition, Including Tables.	mor.	1 50
Weisbach's Kinematics and the Power of Transmission. (Herrmann—Klein).	8vo,	5 00
Machinery of Transmission and Governors. (Herrmann—Klein).	8vo,	5 00
Wood's Turbines.	8vo,	2 50

MATERIALS OF ENGINEERING.

Burr's Elasticity and Resistance of the Materials of Engineering.	8vo,	7 50
Church's Mechanics of Engineering.	8vo,	6 00
Mechanics of Solids (Being Parts I, II, III of Mechanics of Engineering).	8vo,	4 50
* Greene's Structural Mechanics.	8vo,	2 50
Holley's Analysis of Paint and Varnish Products. (In Press.)		
* Lead and Zinc Pigments.	Large 12mo,	3 00
Johnson's (C. M.) Rapid Methods for the Chemical Analysis of Special Steels, Steel-Making Alloys and Graphite	Large 12mo,	3 00
Johnson's (J. B.) Materials of Construction.	8vo,	6 00
Keep's Cast Iron.	8vo,	2 50
* King's Elements of the Mechanics of Materials and of Power of Transmission	8vo,	2 50
Lanza's Applied Mechanics.	8vo,	7 50
Lowe's Paints for Steel Structures.	12mo,	1 00
Maire's Modern Pigments and their Vehicles.	12mo,	2 00

Maurer's Technical Mechanics.	8vo,	\$4 00
Merriman's Mechanics of Materials.	8vo,	5 00
* Strength of Materials.	12mo,	1 00
Metcalf's Steel. A Manual for Steel-users.	12mo,	2 00
* Murdock's Strength of Materials.	12mo,	2 00
Sabin's Industrial and Artistic Technology of Paint and Varnish.	8vo,	3 00
Smith's (A. W.) Materials of Machines.	12mo,	1 00
* Smith's (H. E.) Strength of Material.	12mo,	1 25
Thurston's Materials of Engineering.	3 vols., 8vo,	8 00
Part I. Non-metallic Materials of Engineering.	8vo,	2 00
Part II. Iron and Steel.	8vo,	3 50
Part III. A Treatise on Brasses, Bronzes, and Other Alloys and their Constituents.	8vo,	2 50
Waterbury's Laboratory Manual for Testing Materials of Construction. (In Press.)		
Wood's (De V.) Elements of Analytical Mechanics.	8vo,	3 00
Treatise on the Resistance of Materials and an Appendix on the Preservation of Timber.	8vo,	2 00
Wood's (M. P.) Rustless Coatings: Corrosion and Electrolysis of Iron and Steel.	8vo,	4 00

STEAM-ENGINES AND BOILERS.

Berry's Temperature-entropy Diagram. Third Edition Revised and En- larged.	12mo,	2 50
Carnot's Reflections on the Motive Power of Heat. (Thurston.)	12mo,	1 50
Chase's Art of Pattern Making.	12mo,	2 50
Creighton's Steam-engine and other Heat Motors.	8vo,	5 00
Dawson's "Engineering" and Electric Traction Pocket-book. ...	16mo, mor.	5 00
* Gebhardt's Steam Power Plant Engineering.	8vo,	6 00
Goss's Locomotive Performance.	8vo,	5 00
Hemenway's Indicator Practice and Steam-engine Economy.	12mo,	2 00
Hirshfeld and Barnard's Heat Power Engineering. (In Press.)		
Hutton's Heat and Heat-engines.	8vo,	5 00
Mechanical Engineering of Power Plants.	8vo,	5 00
Kent's Steam Boiler Economy.	8vo,	4 00
Kneass's Practice and Theory of the Injector.	8vo,	1 50
MacCord's Slide-valves.	8vo,	2 00
Meyer's Modern Locomotive Construction.	4to,	10 00
Miller, Berry, and Riley's Problems in Thermodynamics.	8vo, paper,	0 75
Moyer's Steam Turbine.	8vo,	4 00
Peabody's Manual of the Steam-engine Indicator.	12mo,	1 50
Tables of the Properties of Steam and Other Vapors and Temperature- Entropy Table.	8vo,	1 00
Thermodynamics of the Steam-engine and Other Heat-engines. ...	8vo,	5 00
* Thermodynamics of the Steam Turbine.	8vo,	3 00
Valve-gears for Steam-engines.	8vo,	2 50
Peabody and Miller's Steam-boilers.	8vo,	4 00
* Perkins's Introduction to General Thermodynamics.	12mo.	1 50
Pupin's Thermodynamics of Reversible Cycles in Gases and Saturated Vapors. (Osterberg).	12mo,	1 25
Reagan's Locomotives: Simple, Compound, and Electric. New Edition. Large	12mo,	3 50
* Sinclair's Locomotive Engine Running and Management.	12mo,	2 00
Smart's Handbook of Engineering Laboratory Practice.	12mo,	2 50
Snow's Steam-boiler Practice.	8vo,	3 00
Spangler's Notes on Thermodynamics.	12mo,	1 00
Valve-gears.	8vo,	2 50
Spangler, Greene, and Marshall's Elements of Steam-engineering. ...	8vo,	3 00
Thomas's Steam-turbines.	8vo,	4 00
Thurston's Handbook of Engine and Boiler Trials, and the Use of the Indi- cator and the Prony Brake.	8vo,	5 00
Handy Tables.	8vo,	1 50
Manual of Steam-boilers, their Designs, Construction, and Operation	8vo,	5 00
Manual of the Steam-engine.	2 vols., 8vo,	10 00
Part I. History, Structure, and Theory.	8vo,	6 00
Part II. Design, Construction, and Operation.	8vo,	6 00

Wehrenfennig's Analysis and Softening of Boiler Feed-water. (Patterson)	8vo,	\$4 00
Weisbach's Heat, Steam, and Steam-engines. (Du Bois.)	8vo,	5 00
Whitham's Steam-engine Design.	8vo,	5 00
Wood's Thermodynamics, Heat Motors, and Refrigerating Machines.	8vo,	4 00

MECHANICS PURE AND APPLIED.

Church's Mechanics of Engineering.	8vo,	6 00
Mechanics of Fluids (Being Part IV of Mechanics of Engineering).	8vo,	3 00
* Mechanics of Internal Work.	8vo,	1 50
Mechanics of Solids (Being Parts I, II, III of Mechanics of Engineering).	8vo,	4 50
Notes and Examples in Mechanics.	8vo,	2 00
Dana's Text-book of Elementary Mechanics for Colleges and Schools.	12mo,	1 50
Du Bois's Elementary Principles of Mechanics:		
Vol. I. Kinematics.	8vo,	3 50
Vol. II. Statics.	8vo,	4 00
Mechanics of Engineering. Vol. I.	Small 4to,	7 50
Vol. II.	Small 4to,	10 00
* Greene's Structural Mechanics.	8vo,	2 50
* Hartmann's Elementary Mechanics for Engineering Students.	12mo,	1 25
James's Kinematics of a Point and the Rational Mechanics of a Particle.	Large 12mo,	2 00
* Johnson's (W. W.) Theoretical Mechanics.	12mo,	3 00
* King's Elements of the Mechanics of Materials and of Power of Transmission.	8vo,	2 50
Lanza's Applied Mechanics.	8vo,	7 50
* Martin's Text Book on Mechanics, Vol. I, Statics.	12mo,	1 25
* Vol. II. Kinematics and Kinetics.	12mo,	1 50
* Vol. III. Mechanics of Materials.	12mo,	1 50
Maurer's Technical Mechanics.	8vo,	4 00
* Merriman's Elements of Mechanics.	12mo,	1 00
Mechanics of Materials.	8vo,	5 00
* Michie's Elements of Analytical Mechanics.	8vo,	4 00
Robinson's Principles of Mechanism.	8vo,	3 00
Sanborn's Mechanics Problems.	Large 12mo,	1 50
Schwamb and Merrill's Elements of Mechanism.	8vo,	3 00
Wood's Elements of Analytical Mechanics.	8vo,	3 00
Principles of Elementary Mechanics.	12mo,	1 25

MEDICAL.

* Abderhalden's Physiological Chemistry in Thirty Lectures. (Hall and Defren.)	8vo,	5 00
von Behring's Suppression of Tuberculosis. (Bolduan.)	12mo,	1 00
* Bolduan's Immune Sera.	12mo,	1 50
Bordet's Studies in Immunity. (Gay.)	8vo,	6 00
* Chapin's The Sources and Modes of Infection.	Large 12mo,	3 00
Davenport's Statistical Methods with Special Reference to Biological Variations.	16mo, mor.	1 50
Ehrlich's Collected Studies on Immunity. (Bolduan.)	8vo,	6 00
* Fischer's Nephritis.	Large 12mo,	2 50
* Oedema.	8vo,	2 00
* Physiology of Alimentation.	Large 12mo,	2 00
* de Fursac's Manual of Psychiatry. (Rosanoff and Collins.)	Large 12mo,	2 50
* Hammarsten's Text-book on Physiological Chemistry. (Mandel.)	8vo,	4 00
Jackson's Directions for Laboratory Work in Physiological Chemistry.	8vo,	1 25
Lassar-Cohn's Praxis of Urinary Analysis. (Lorenz.)	12mo,	1 00
Mandel's Hand-book for the Bio-Chemical Laboratory.	12mo,	1 50
* Nelson's Analysis of Drugs and Medicines.	12mo,	3 00
* Pauli's Physical Chemistry in the Service of Medicine. (Fischer.)	12mo,	1 25
* Pozzi-Escot's Toxins and Venoms and their Antibodies. (Cohn.)	12mo,	1 00
Rostoski's Serum Diagnosis. (Bolduan.)	12mo,	1 00
Ruddiman's Incompatibilities in Prescriptions.	8vo,	2 00
Whys in Pharmacy.	12mo,	1 00
Salkowski's Physiological and Pathological Chemistry. (Orndorff.)	8vo,	2 50

* Satterlee's Outlines of Human Embryology.	12mo,	\$1 25
Smith's Lecture Notes on Chemistry for Dental Students.	8vo,	2 50
* Whipple's Typhoid Fever.	Large 12mo,	3 00
* Woodhull's Military Hygiene for Officers of the Line	Large 12mo,	1 50
* Personal Hygiene.	12mo,	1 00
Worcester and Atkinson's Small Hospitals Establishment and Maintenance, and Suggestions for Hospital Architecture, with Plans for a Small Hospital.	12mo,	1 25

METALLURGY.

Betts's Lead Refining by Electrolysis.	8vo,	4 00
Bolland's Encyclopedia of Founding and Dictionary of Foundry Terms used in the Practice of Moulding.	12mo,	3 00
Iron Founder.	12mo,	2 50
" " Supplement.	12mo,	2 50
* Borchers's Metallurgy. (Hall and Hayward.)	8vo,	3 00
* Burgess and Le Chatelier's Measurement of High Temperatures. Third Edition.	8vo,	4 00
Douglas's Untechnical Addresses on Technical Subjects.	12mo,	1 00
Goesel's Minerals and Metals: A Reference Book.	16mo, mor.	3 00
* Iles's Lead-smelting.	12mo,	2 50
Johnson's Rapid Methods for the Chemical Analysis of Special Steels, Steel-making Alloys and Graphite.	Large 12mo,	3 00
Keep's Cast Iron.	8vo,	2 50
Metcalf's Steel. A Manual for Steel-users.	12mo,	2 00
Minet's Production of Aluminum and its Industrial Use. (Waldo.)	12mo,	2 50
* Palmer's Foundry Practice.	Large 12mo,	2 00
* Price and Meade's Technical Analysis of Brass.	12mo,	2 00
* Ruer's Elements of Metallography. (Mathewson.)	8vo,	3 00
Smith's Materials of Machines.	12mo,	1 00
Tate and Stone's Foundry Practice.	12mo,	2 00
Thurston's Materials of Engineering. In Three Parts.	8vo,	8 00
Part I. Non-metallic Materials of Engineering, see Civil Engineering, page 9.		
Part II. Iron and Steel.	8vo,	3 50
Part III. A Treatise on Brasses, Bronzes, and Other Alloys and their Constituents.	8vo,	2 50
Ulke's Modern Electrolytic Copper Refining.	8vo,	3 00
West's American Foundry Practice.	12mo,	2 50
Moulders' Text Book.	12mo.	2 50

MINERALOGY.

* Browning's Introduction to the Rarer Elements.	8vo,	1 50
Brush's Manual of Determinative Mineralogy. (Penfield.)	8vo,	4 00
Butler's Pocket Hand-book of Minerals.	16mo, mor.	3 00
Chester's Catalogue of Minerals.	8vo, paper,	1 00
	Cloth,	1 25
* Crane's Gold and Silver.	8vo,	5 00
Dana's First Appendix to Dana's New "System of Mineralogy"	Large 8vo,	1 00
Dana's Second Appendix to Dana's New "System of Mineralogy."	Large 8vo,	1 50
Manual of Mineralogy and Petrography.	12mo,	2 00
Minerals and How to Study Them.	12mo,	1 50
System of Mineralogy.	Large 8vo, half leather,	12 50
Text-book of Mineralogy.	8vo,	4 00
Douglas's Untechnical Addresses on Technical Subjects.	12mo,	1 00
Eakle's Mineral Tables.	8vo,	1 25
* Eckel's Building Stones and Clays.	8vo,	3 00
Goesel's Minerals and Metals: A Reference Book.	16mo, mor.	3 00
* Groth's The Optical Properties of Crystals. (Jackson.)	8vo,	3 50
Groth's Introduction to Chemical Crystallography (Marshall).	12mo,	1 25
* Hayes's Handbook for Field Geologists.	16mo, mor.	1 50
Iddings's Igneous Rocks.	8vo,	5 00
Rock Minerals.	8vo,	5 00

Johannsen's Determination of Rock-forming Minerals in Thin Sections. 8vo, With Thumb Index	\$5 00
* Martin's Laboratory Guide to Qualitative Analysis with the Blow- pipe.	12mo, 0 60
Merrill's Non-metallic Minerals: Their Occurrence and Uses.	8vo, 4 00
Stones for Building and Decoration.	8vo, 5 00
* Penfield's Notes on Determinative Mineralogy and Record of Mineral Tests. 8vo, paper,	0 50
Tables of Minerals, Including the Use of Minerals and Statistics of Domestic Production.	8vo, 1 00
* Pirsson's Rocks and Rock Minerals.	12mo, 2 50
* Richards's Synopsis of Mineral Characters.	12mo, mor. 1 25
* Ries's Clays: Their Occurrence, Properties and Uses.	8vo, 5 00
* Ries and Leighton's History of the Clay-working Industry of the United States.	8vo, 2 50
* Rowe's Practical Mineralogy Simplified.	12mo, 1 25
* Tillman's Text-book of Important Minerals and Rocks.	8vo, 2 00
Washington's Manual of the Chemical Analysis of Rocks.	8vo, 2 00

MINING.

* Beard's Mine Gases and Explosions.	Large 12mo, 3 00
* Crane's Gold and Silver.	8vo, 5 00
* Index of Mining Engineering Literature.	8vo, 4 00
* Ore Mining Methods.	8vo, mor. * 8vo, 5 00
* Dana and Saunders's Rock Drilling.	8vo, 3 00
* Douglas's Untechnical Addresses on Technical Subjects.	12mo, 4 00
Eissler's Modern High Explosives.	8vo, 1 00
Goesel's Minerals and Metals: A Reference Book.	16mo, mor. 3 00
Ihlseng's Manual of Mining.	8vo, 5 00
* Iles's Lead Smelting.	12mo, 2 50
* Peele's Compressed Air Plant.	8vo, 3 50
Riemer's Shaft Sinking Under Difficult Conditions. (Corning and Peele.)	8vo, 3 00
* Weaver's Military Explosives.	8vo, 3 00
Wilson's Hydraulic and Placer Mining. 2d edition, rewritten.	12mo, 2 50
Treatise on Practical and Theoretical Mine Ventilation.	12mo, 1 25

SANITARY SCIENCE.

Association of State and National Food and Dairy Departments, Hartford Meeting, 1906.	8vo, 3 00
Jamestown Meeting, 1907.	8vo, 3 00
* Bashore's Outlines of Practical Sanitation.	12mo, 1 25
Sanitation of a Country House.	12mo, 1 00
Sanitation of Recreation Camps and Parks.	12mo, 1 00
* Chapin's The Sources and Modes of Infection.	Large 12mo, 3 00
Folwell's Sewerage. (Designing, Construction, and Maintenance.).	8vo, 3 00
Water-supply Engineering.	8vo, 4 00
Fowler's Sewage Works Analyses.	12mo, 2 00
Fuertes's Water-filtration Works.	12mo, 2 50
Water and Public Health.	12mo, 1 50
Gerhard's Guide to Sanitary Inspections.	12mo, 1 50
* Modern Baths and Bath Houses.	8vo, 3 00
Sanitation of Public Buildings.	12mo, 1 50
* The Water Supply, Sewerage, and Plumbing of Modern City Buildings. 8vo,	4 00
Hazen's Clean Water and How to Get It.	Large 12mo, 1 50
Filtration of Public Water-supplies.	8vo, 3 00
* Kinnicutt, Winslow and Pratt's Sewage Disposal.	8vo, 3 00
Leach's Inspection and Analysis of Food with Special Reference to State Control.	8vo, 7 50
Mason's Examination of Water. (Chemical and Bacteriological).	12mo, 1 25
Water-supply. (Considered principally from a Sanitary Standpoint). 8vo,	4 00
* Mast's Light and the Behavior of Organisms.	Large 12mo, 2 50

* Merriman's Elements of Sanitary Engineering.	8vo,	\$2 00
Ogden's Sewer Construction	8vo,	3 00
Sewer Design.	12mo,	2 00
Parsons's Disposal of Municipal Refuse.	8vo,	2 00
Prescott and Winslow's Elements of Water Bacteriology, with Special Reference to Sanitary Water Analysis.	12mo,	1 50
* Price's Handbook on Sanitation.	12mo,	1 50
Richards's Conservation by Sanitation.	8vo,	2 50
Cost of Cleanness.	12mo,	1 00
Cost of Food. A Study in Dietaries.	12mo,	1 00
Cost of Living as Modified by Sanitary Science.	12mo,	1 00
Cost of Shelter.	12mo,	1 00
Richards and Woodman's Air, Water, and Food from a Sanitary Standpoint.	8vo,	2 00
* Richey's Plumbers', Steam-fitters', and Tinnners' Edition (Building Mechanics' Ready Reference Series).	16mo,	1 50
Rideal's Disinfection and the Preservation of Food.	8vo,	4 00
Soper's Air and Ventilation of Subways.	12mo,	2 50
Turneaure and Russell's Public Water-supplies.	8vo,	5 00
Venable's Garbage Crematories in America.	8vo,	2 00
Method and Devices for Bacterial Treatment of Sewage.	8vo,	3 00
Ward and Whipple's Freshwater Biology. (In Press.)		
Whipple's Microscopy of Drinking-water.	8vo,	3 50
* Typhoid Fever.	Large 12mo,	3 00
Value of Pure Water.	Large 12mo,	1 00
Winslow's Systematic Relationship of the Coccaceæ.	Large 12mo,	2 50

MISCELLANEOUS.

* Burt's Railway Station Service.	12mo,	2 00
* Chapin's How to Enamel.	12mo.	1 00
Emmons's Geological Guide-book of the Rocky Mountain Excursion of the International Congress of Geologists.	Large 8vo,	1 50
Ferrel's Popular Treatise on the Winds.	8vo,	4 00
Fitzgerald's Boston Machinist.	18mo,	1 00
* Fritz, Autobiography of John.	8vo,	2 00
Gannett's Statistical Abstract of the World.	24mo,	0 75
Haines's American Railway Management.	12mo,	2 50
Hanausek's The Microscopy of Technical Products. (Winton).	8vo,	5 00
Jacobs's Betterment Briefs. A Collection of Published Papers on Organized Industrial Efficiency.	8vo,	3 50
Metcalfe's Cost of Manufactures, and the Administration of Workshops. 8vo,		5 00
* Parkhurst's Applied Methods of Scientific Management.	8vo,	2 00
Putnam's Nautical Charts.	8vo,	2 00
Ricketts's History of Rensselaer Polytechnic Institute 1824-1894.	Large 12mo,	3 00
* Rotch and Palmer's Charts of the Atmosphere for Aeronauts and Aviators.	Oblong 4to,	2 00
Rotherham's Emphasised New Testament.	Large 8vo,	2 00
Rust's Ex-Meridian Altitude, Azimuth and Star-finding Tables.	8vo	5 00
Standage's Decoration of Wood, Glass, Metal, etc.	12mo	2 00
Thome's Structural and Physiological Botany. (Bennett).	16mo,	2 25
Westermaier's Compendium of General Botany. (Schneider).	8vo,	2 00
Winslow's Elements of Applied Microscopy.	12mo,	1 50

HEBREW AND CHALDEE TEXT-BOOKS.

Gesenius's Hebrew and Chaldee Lexicon to the Old Testament Scriptures. (Tregelles.)	Small 4to, half mor,	5 00
Green's Elementary Hebrew Grammar.	12mo	1 25

